

Ceramic Low Pass Filter

DC to 1575 MHz

NEW!
LFCN-1575



BLUE CELL™

CASE STYLE: FV1206

Model	Price	Qty.
LFCN-1575	\$2.99	(10-49)
LFCN-1575D	\$3.49	(10-49)

Maximum Ratings

Operating Temperature	-55°C to 100°C
Storage Temperature	-55°C to 100°C
RF Power Input*	10W max. at 25°C
DC Current Input to Output	0.5A max. at 25°C

*Passband rating, derate linearly to 3.5W at 100°C ambient.

Pin Connections

RF IN	1**
RF OUT	3**
GROUND	2,4

**RF IN & RF OUT can be interchanged

Outline Drawing

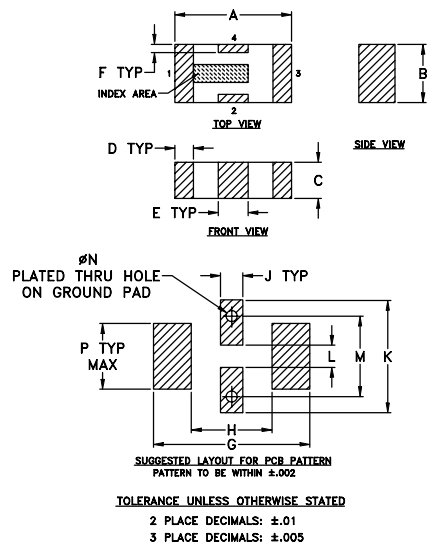

Outline Dimensions (inch)

A	B	C	D	E	F	G
.126	.063	.037	.020	.032	.009	.169
3.20	1.60	0.94	0.51	0.81	0.23	4.29

H	J	K	L	M	N	P	wt
.087	.024	.122	.024	.087	.012	.071	grams
2.21	0.61	3.10	0.61	2.21	0.30	1.80	.020

Demo Board MCL P/N: TB-270
Suggested PCB Layout (PL-137)

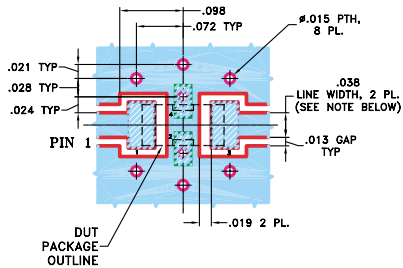

Features

- excellent power handling, 10W
- small size
- 7 sections
- temperature stable
- patent pending

Applications

- harmonic rejection
- VHF/UHF transmitters/receivers
- lab use

Low Pass Filter Electrical Specifications¹ (T_{AMB}=25°C)

MODEL NO.	PASSBAND (MHz) (loss < 1 dB) Max.	f _{co} , MHz Nom. (loss 3 dB) Typ.	STOP BAND (MHz) (loss, dB)			VSWR (:1)		NO. OF SECTIONS
			f 20 Min.	30 Typ.	f _r 20 Typ.	Stopband Typ.	Passband Typ.	
LFCN-1575	DC-1575	1875	2175	2225-6800	7100	20	1.2	7

1. For Applications requiring DC voltage to be applied to the Input or output, use LFCN-1575D (DC Resistance to ground is 100 Mohms min.)

typical frequency response

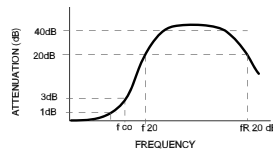

schematic

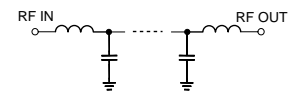

Typical Performance Data at 25°C

Frequency (MHz)	Insertion Loss (dB)	VSWR (:1)
100.00	0.08	1.03
1000.00	0.36	1.11
1575.00	0.76	1.21
1875.00	2.32	2.03
2000.00	7.66	5.56
2200.00	35.08	16.11
2275.00	32.67	18.90
2500.00	41.82	26.33
2700.00	37.22	32.18
4000.00	41.10	51.10
5000.00	43.27	48.26
6000.00	37.34	34.07
6800.00	35.05	27.16
7200.00	20.70	18.90
9000.00	16.86	17.57

