

256K x 8 LOW POWER and LOW Vcc CMOS STATIC RAM

APRIL 2000

FEATURES

- Access times of 70 and 85 ns
- CMOS low power operation:
 - 120 mW (typical) operating
 - 6 μ W (typical) standby
- Low data retention voltage: 2V (min.)
- Output Enable (\overline{OE}) and two Chip Enable ($\overline{CE1}$ and CE2) inputs for ease in applications
- TTL compatible inputs and outputs
- Fully static operation:
 - No clock or refresh required
- Single 2.5V to 3.0V power supply
- Available in 32-pin TSOP (Type I), STSOP (Type I), and 36-pin mini BGA

DESCRIPTION

The *ISSI* IS62LV2568LL is a low voltage, 262,144 words by 8 bits, CMOS SRAM. It is fabricated using *ISSI*'s low voltage, six transistor (6T), CMOS technology. The device is targeted to satisfy the demands of the state-of-the-art technologies such as cell phones and pagers.

When \overline{CE} is HIGH (deselected), the device assumes a standby mode at which the power dissipation can be reduced down with CMOS input levels. Additionally, easy memory expansion is provided by using Chip Enable and Output Enable inputs, \overline{CE} and \overline{OE} . The active LOW Write Enable (\overline{WE}) controls both writing and reading of the memory.

The IS62LV2568LL is available in 32-pin TSOP (Type I), STSOP (Type I), and 36-pin mini BGA.

FUNCTIONAL BLOCK DIAGRAM

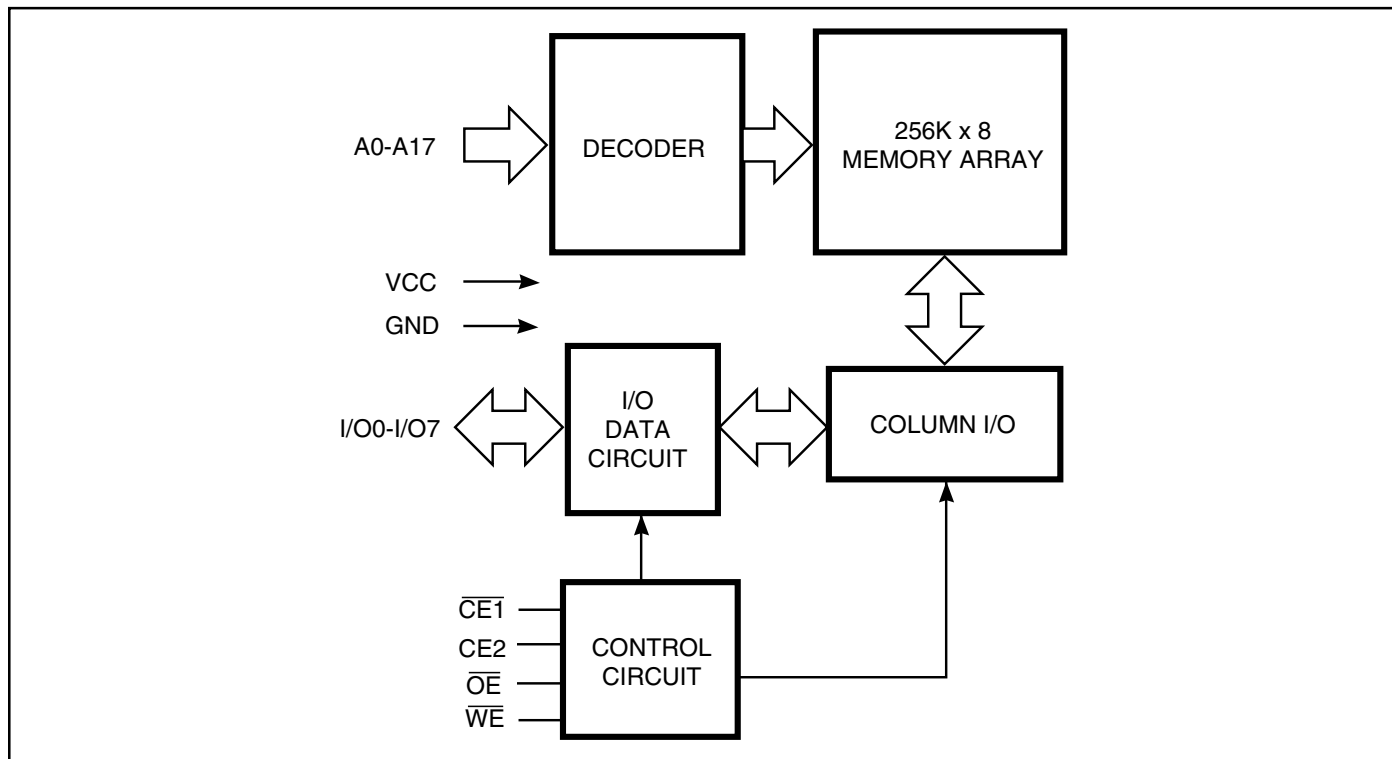

ISSI reserves the right to make changes to its products at any time without notice in order to improve design and supply the best possible product. We assume no responsibility for any errors which may appear in this publication. © Copyright 2000, Integrated Silicon Solution, Inc.

PIN CONFIGURATION

36-pin mini BGA (B)

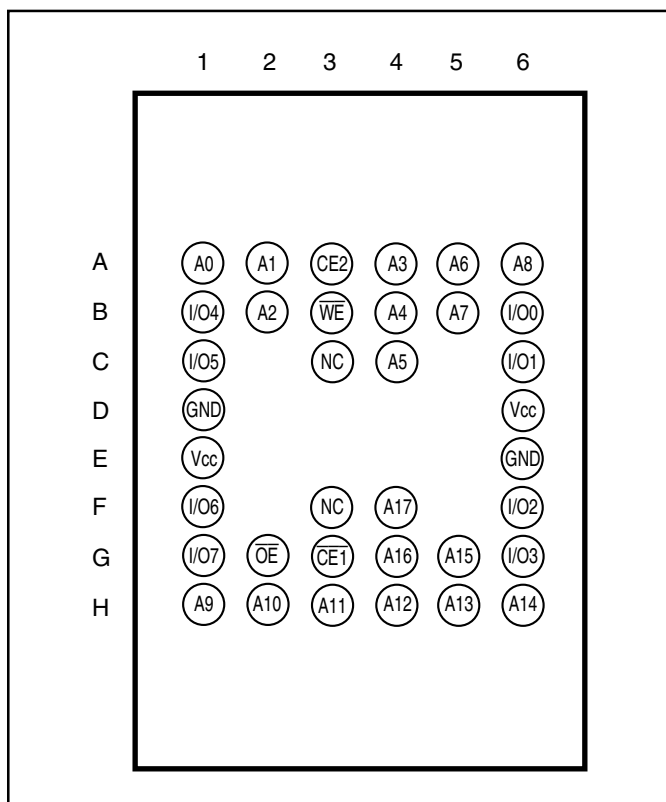

PIN DESCRIPTIONS

A0-A17	Address Inputs
CE1	Chip Enable 1 Input
CE2	Chip Enable 2 Input
OE	Output Enable Input
WE	Write Enable Input
I/O0-I/O7	Input/Output
NC	No Connection
Vcc	Power
GND	Ground

32-Pin TSOP (Type I), STSOP (Type I)

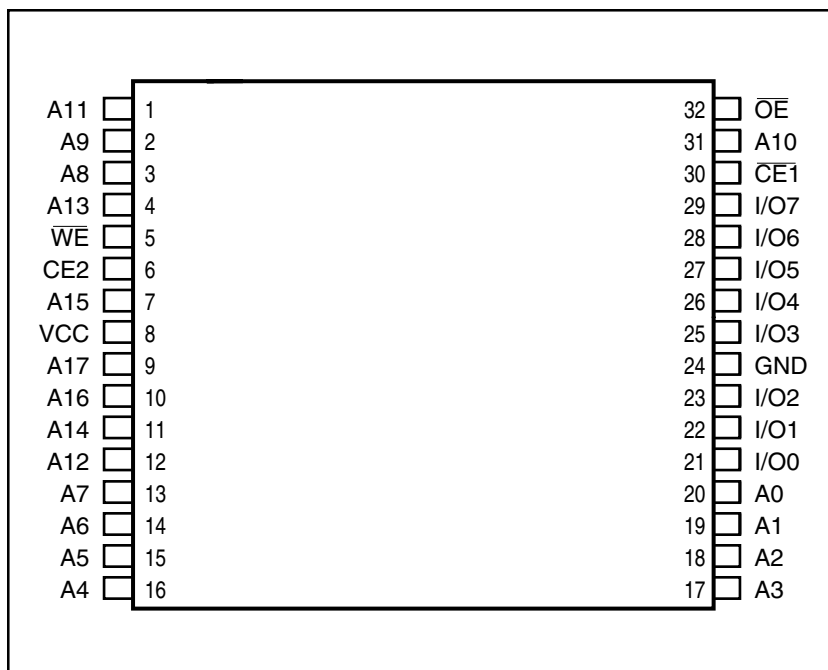

TRUTH TABLE

Mode	\overline{WE}	$\overline{CE1}$	CE2	\overline{OE}	I/O Operation	Vcc Current
Not Selected	X	H	X	X	High-Z	I _{SB1} , I _{SB2}
(Power-down)	X	X	L	X	High-Z	I _{SB1} , I _{SB2}
Output Disabled	H	L	H	H	High-Z	I _{CC}
Read	H	L	H	L	D _{OUT}	I _{CC}
Write	L	L	H	X	D _{IN}	I _{CC}

OPERATING RANGE

Range	Ambient Temperature	Vcc
Commercial	0°C to +70°C	2.5V to 3.0V
Industrial	-40°C to +85°C	2.5V to 3.0V

ABSOLUTE MAXIMUM RATINGS⁽¹⁾

Symbol	Parameter	Value	Unit
V _{TERM}	Terminal Voltage with Respect to GND	-0.5 to V _{CC} + 0.5	V
V _{CC}	V _{CC} related to GND	-0.3 to +4.6	V
T _{BIAS}	Temperature Under Bias	-40 to +85	°C
T _{STG}	Storage Temperature	-65 to +150	°C
P _T	Power Dissipation	0.7	W

Note:

1. Stress greater than those listed under ABSOLUTE MAXIMUM RATINGS may cause permanent damage to the device. This is a stress rating only and functional operation of the device at these or any other conditions above those indicated in the operational sections of this specification is not implied. Exposure to absolute maximum rating conditions for extended periods may affect reliability.

CAPACITANCE^(1,2)

Symbol	Parameter	Conditions	Max.	Unit
C _{IN}	Input Capacitance	V _{IN} = 0V	6	pF
C _{OUT}	Output Capacitance	V _{OUT} = 0V	8	pF

Notes:

1. Tested initially and after any design or process changes that may affect these parameters.
2. Test conditions: T_A = 25°C, f = 1 MHz, V_{CC} = 3.0V.

DC ELECTRICAL CHARACTERISTICS (Over Operating Range)

Symbol	Parameter	Test Conditions	Min.	Max.	Unit
V _{OH}	Output HIGH Voltage	V _{CC} = Min., I _{OH} = -1.0 mA	2.0	—	V
V _{OL}	Output LOW Voltage	V _{CC} = Min., I _{OL} = 2.1 mA	—	0.4	V
V _{IH}	Input HIGH Voltage		2.2	V _{CC} + 0.3	V
V _{IL}	Input LOW Voltage ⁽¹⁾		-0.3	0.4	V
I _{LI}	Input Leakage	GND ≤ V _{IN} ≤ V _{CC}	-1	1	μA
I _{LO}	Output Leakage	GND ≤ V _{OUT} ≤ V _{CC}	-1	1	μA

Note:

1. V_{IL} = -3.0V for pulse width less than 10 ns.

POWER SUPPLY CHARACTERISTICS⁽¹⁾ (Over Operating Range)

Symbol	Parameter	Test Conditions	-70		-85		Unit	
			Min.	Max.	Min.	Max.		
I _{CC}	V _{CC} Dynamic Operating Supply Current	V _{CC} = Max., CE = V _{IL} I _{OUT} = 0 mA, f = f _{MAX}	Com.	—	30	—	25	mA
			Ind.	—	35	—	30	
I _{SB1}	TTL Standby Current (TTL Inputs)	V _{CC} = Max., V _{IN} = V _{IH} or V _{IL} , CE1 ≥ V _{IH} or CE2 ≤ V _{IL} , f = 0	Com.	—	0.4	—	0.4	mA
			Ind.	—	1.0	—	1.0	
I _{SB2}	CMOS Standby Current (CMOS Inputs)	V _{CC} = Max., f = 0 CE1 ≥ V _{CC} - 0.2V, CE2 ≤ 0.2V, or V _{IN} ≥ V _{CC} - 0.2V, V _{IN} ≤ 0.2V	Com.	—	5	—	5	μA
			Ind.	—	5	—	5	

Note:

1. At f = f_{MAX}, address and data inputs are cycling at the maximum frequency, f = 0 means no input lines change.

READ CYCLE SWITCHING CHARACTERISTICS⁽¹⁾ (Over Operating Range)

Symbol	Parameter	-70		-85		Unit
		Min.	Max.	Min.	Max.	
t _{RC}	Read Cycle Time	70	—	85	—	ns
t _{AA}	Address Access Time	—	70	—	85	ns
t _{OHA}	Output Hold Time	10	—	15	—	ns
t _{ACE1}	$\overline{CE1}$ Access Time	—	70	—	85	ns
t _{ACE2}	CE2 Access Time	—	70	—	85	ns
t _{DOE}	\overline{OE} Access Time	—	35	—	45	ns
t _{HZOE} ⁽²⁾	\overline{OE} to High-Z Output	—	25	—	25	ns
t _{LZOE} ⁽²⁾	\overline{OE} to Low-Z Output	5	—	5	—	ns
t _{LZCE1} ⁽²⁾	$\overline{CE1}$ to Low-Z Output	10	—	10	—	ns
t _{LZCE2} ⁽²⁾	CE2 to Low-Z Output	10	—	10	—	ns
t _{HZCE} ⁽²⁾	$\overline{CE1}$ or CE2 to High-Z Output	0	25	0	25	ns

Notes:

- Test conditions assume signal transition times of 5 ns or less, timing reference levels of 1.3V, input pulse levels of 0.4V to 2.2V and output loading specified in Figure 1.
- Tested with the load in Figure 2. Transition is measured ± 500 mV from steady-state voltage. Not 100% tested.

AC TEST CONDITIONS

Parameter	Unit
Input Pulse Level	0.4V to 2.2V
Input Rise and Fall Times	5 ns
Input and Output Timing and Reference Level	1.3V
Output Load	See Figures 1 and 2

AC TEST LOADS

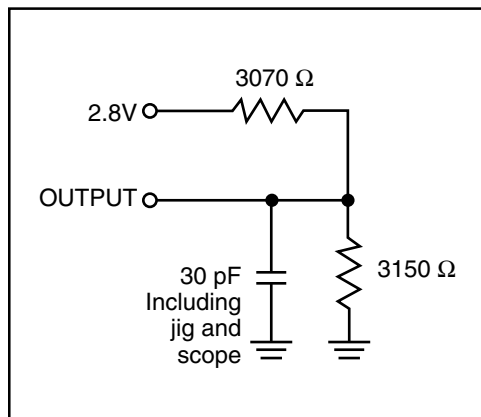

Figure 1

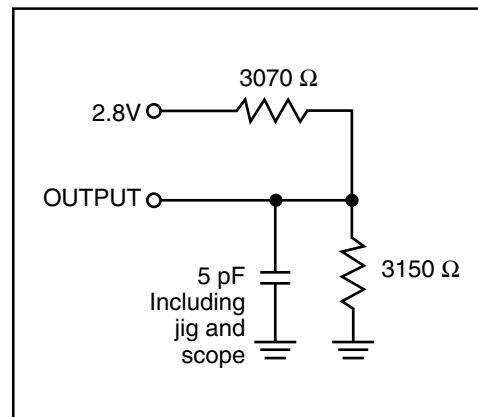
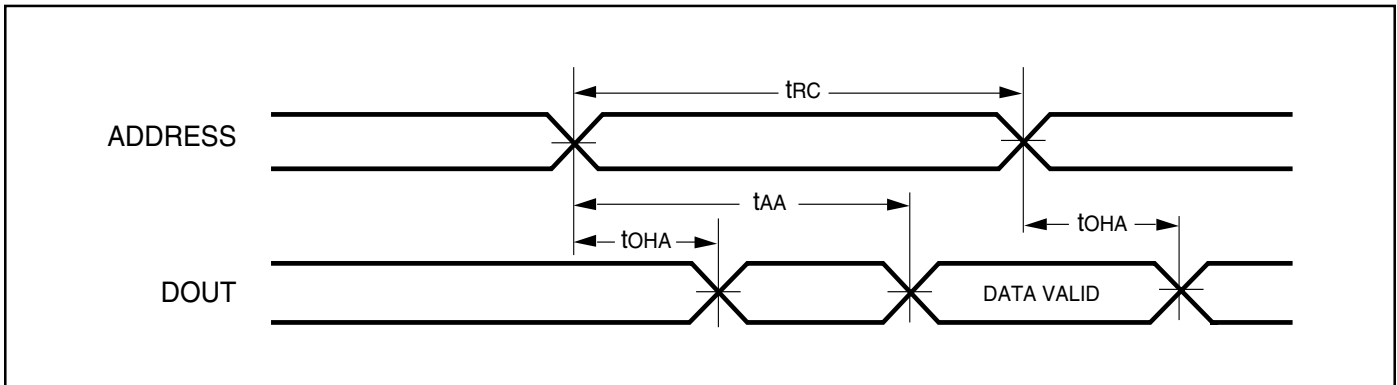

Figure 2

AC WAVEFORMS

READ CYCLE NO. 1^(1,2)



READ CYCLE NO. 2^(1,3)

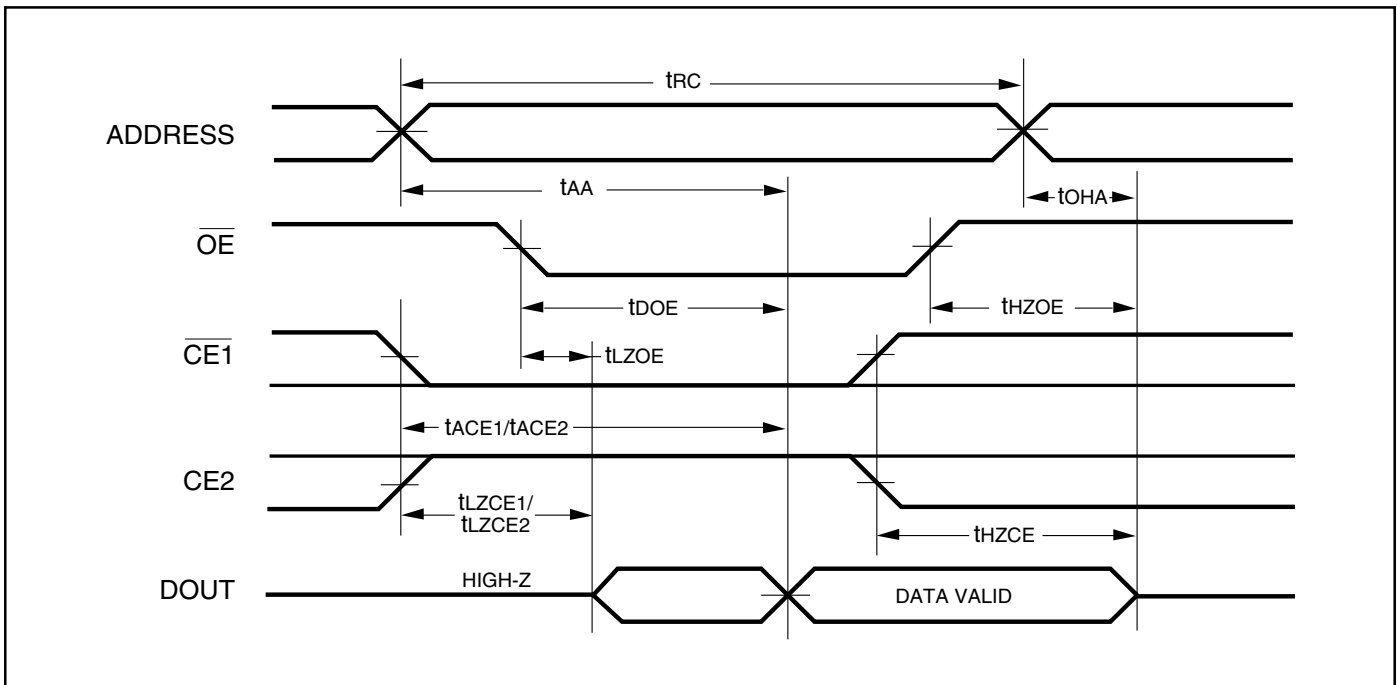

Notes:

1. \overline{WE} is HIGH for a Read Cycle.
2. The device is continuously selected. \overline{OE} , $\overline{CE1} = V_{IL}$, $CE2 = V_{IH}$.
3. Address is valid prior to or coincident with $\overline{CE1}$ LOW and CE2 HIGH transitions.

WRITE CYCLE SWITCHING CHARACTERISTICS^(1,3) (Over Operating Range, Standard and Low Power)

Symbol	Parameter	-70		-85		Unit
		Min.	Max.	Min.	Max.	
t _{WC}	Write Cycle Time	70	—	85	—	ns
t _{SCE1}	$\overline{CE1}$ to Write End	65	—	70	—	ns
t _{SCE2}	CE2 to Write End	65	—	70	—	ns
t _{AW}	Address Setup Time to Write End	65	—	70	—	ns
t _{HA}	Address Hold from Write End	0	—	0	—	ns
t _{SA}	Address Setup Time	0	—	0	—	ns
t _{PWE⁽⁴⁾}	\overline{WE} Pulse Width	60	—	60	—	ns
t _{SD}	Data Setup to Write End	30	—	35	—	ns
t _{HD}	Data Hold from Write End	0	—	0	—	ns
t _{HZWE⁽²⁾}	\overline{WE} LOW to High-Z Output	—	33	—	25	ns
t _{LZWE⁽²⁾}	\overline{WE} HIGH to Low-Z Output	5	—	5	—	ns

Notes:

1. Test conditions assume signal transition times of 5 ns or less, timing reference levels of 1.3V, input pulse levels of 0.4V to 2.2V and output loading specified in Figure 1.
2. Tested with the load in Figure 2. Transition is measured ± 500 mV from steady-state voltage. Not 100% tested.
3. The internal write time is defined by the overlap of $\overline{CE1}$ LOW, CE2 HIGH and \overline{WE} LOW. All signals must be in valid states to initiate a Write, but any one can go inactive to terminate the Write. The Data Input Setup and Hold timing are referenced to the rising or falling edge of the signal that terminates the Write.
4. Tested with \overline{OE} HIGH.

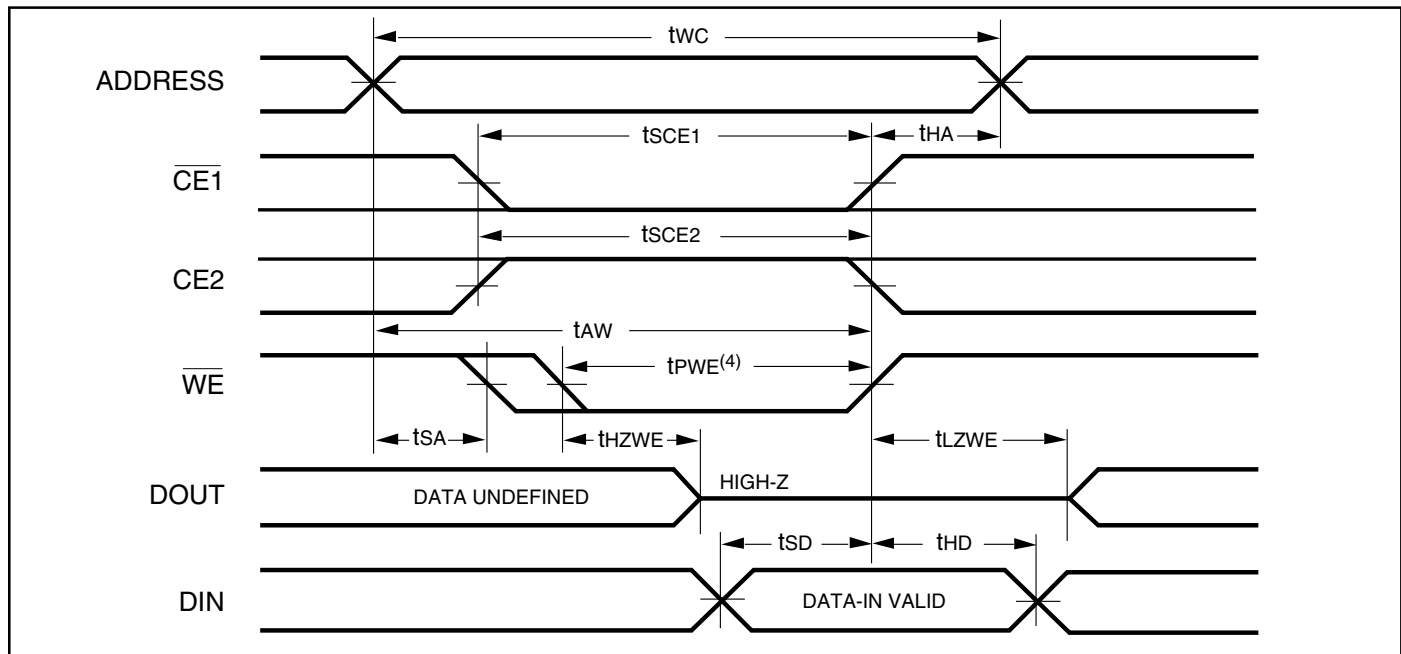
AC WAVEFORMS**WRITE CYCLE NO. 1** (\overline{CE} Controlled, \overline{OE} = HIGH or LOW)

WRITE CYCLE NO. 2 (\overline{WE} Controlled: \overline{OE} is HIGH During Write Cycle)

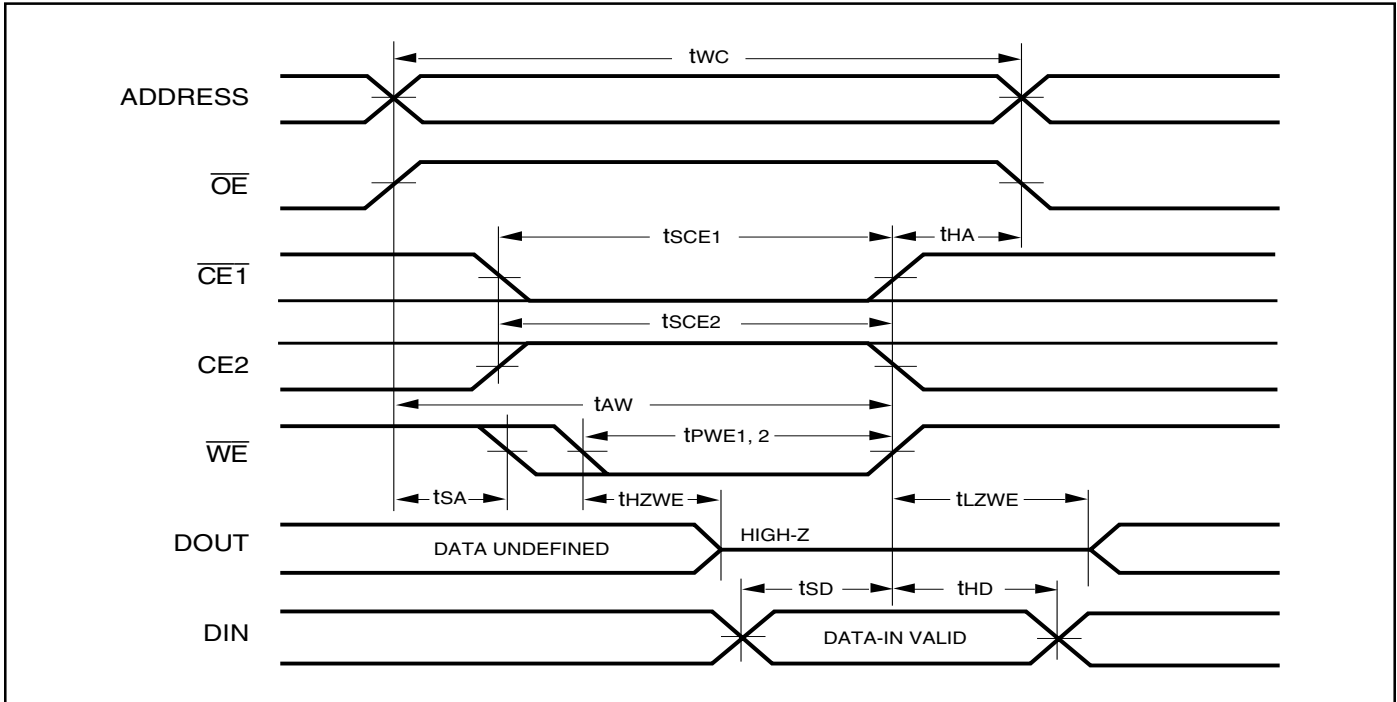

WRITE CYCLE NO. 3 (\overline{WE} Controlled: \overline{OE} is LOW During Write Cycle)

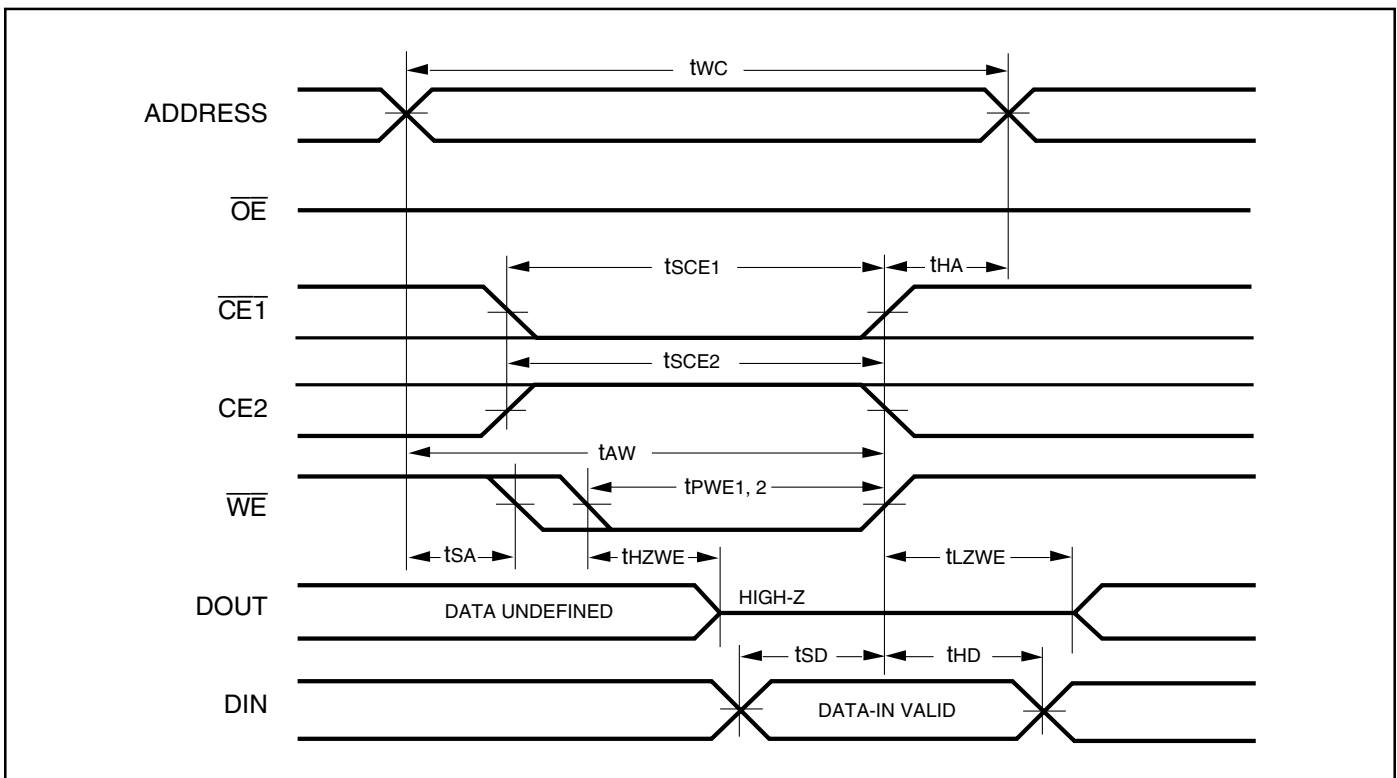

DATA RETENTION SWITCHING CHARACTERISTICS

Symbol	Parameter	Test Condition	Min.	Max.	Unit
V _{DR}	V _{CC} for Data Retention	See Data Retention Waveform	2.0	3.6	V
I _{DR}	Data Retention Current	V _{CC} = 2.0V, $\overline{CE1} \geq V_{CC} - 0.2V$	Com. Ind.	— 2	μA
t _{SDR}	Data Retention Setup Time	See Data Retention Waveform	0	—	ns
t _{RDR}	Recovery Time	See Data Retention Waveform	t _{rc}	—	ns

DATA RETENTION WAVEFORM ($\overline{CE1}$ Controlled)

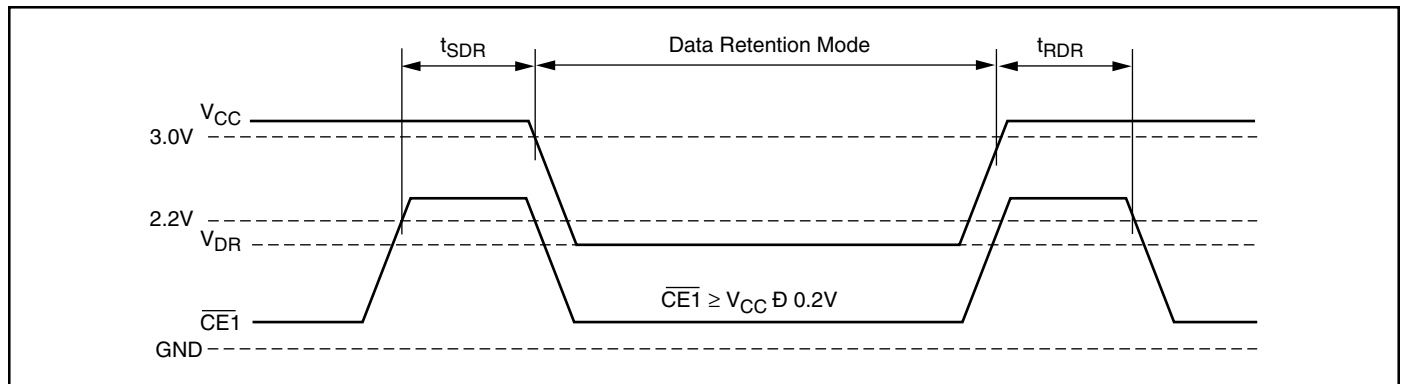

DATA RETENTION WAVEFORM (CE2 Controlled)

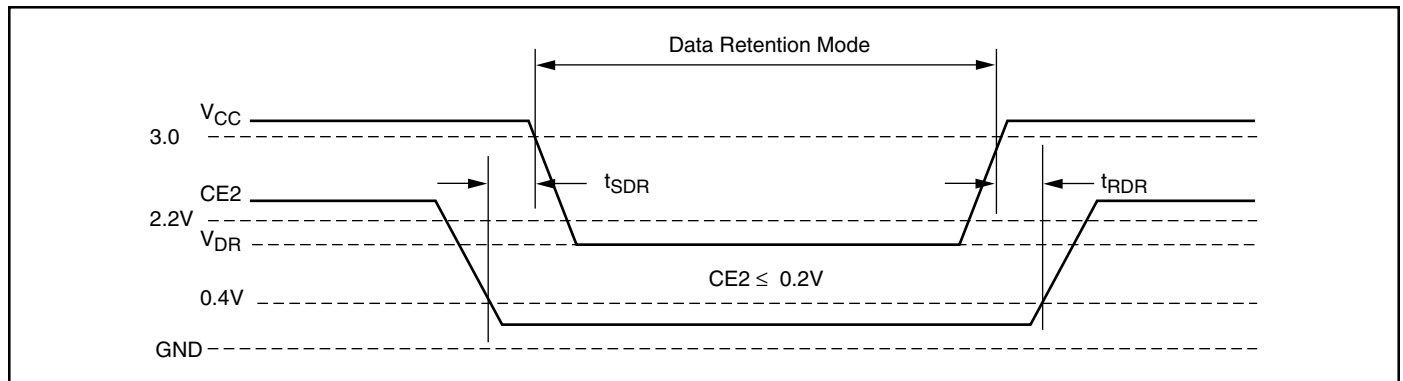

ORDERING INFORMATION**Commercial Range: 0°C to +70°C**

Speed (ns)	Order Part No.	Package
70	IS62LV2568LL-70B	mini BGA (6mm x 8mm)
	IS62LV2568LL-70T	TSOP, Type I
	IS62LV2568LL-70H	STSOP, Type I
85	IS62LV2568LL-85B	mini BGA (6mm x 8mm)
	IS62LV2568LL-85T	TSOP, Type I
	IS62LV2568LL-85H	STSOP, Type I

Industrial Range: -40°C to +85°C

Speed (ns)	Order Part No.	Package
70	IS62LV2568LL-70BI	mini BGA (6mm x 8mm)
	IS62LV2568LL-70TI	TSOP, Type I
	IS62LV2568LL-70HI	STSOP, Type I
85	IS62LV2568LL-85BI	mini BGA (6mm x 8mm)
	IS62LV2568LL-85TI	TSOP, Type I
	IS62LV2568LL-85HI	STSOP, Type I

ISSI®

Integrated Silicon Solution, Inc.

2231 Lawson Lane
 Santa Clara, CA 95054
 Tel: 1-800-379-4774
 Fax: (408) 588-0806
 E-mail: sales@issi.com
www.issi.com