

357947

ZTX212  
ZTX213  
ZTX214

## PNP Silicon Planar General Purpose Transistors

357-947

### DESCRIPTION

These are plastic encapsulated general purpose transistors designed for small and medium signal amplifications from d.c. to radio frequencies. Application areas include: Audio Frequency Amplifiers, Driver and Output Stages, Oscillators and General Purpose Switches.

The E-line package is formed by injection moulding a SILICONE plastic specially selected to provide a rugged one-piece encapsulation resistant to severe environments and allow the high junction temperature operation normally associated with metal can devices.

E-line encapsulated devices are approved for use in military, industrial and professional equipments.

Alternative lead configurations are available as plug-in replacements of TO-5/39 and TO-18 metal can types, and for flat mounting.

The basic types, ZTX212, 213 and 214 are similar to the BC212, 213 and 214 series of transistors.

The ZTX212 series of transistors has been APPROVED FOR USE IN MILITARY EQUIPMENT and are identified by the following numbers: BS 9365 F130 to 132 - Category P

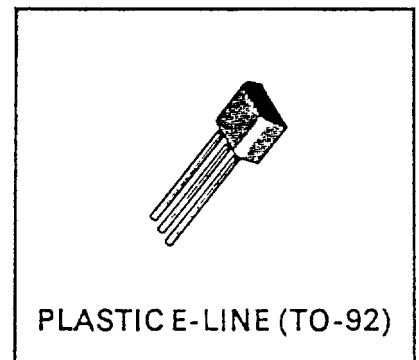

### ABSOLUTE MAXIMUM RATINGS

Parameter	Symbol	ZTX212	ZTX213	ZTX214	Unit
Collector-Base Voltage	$V_{CBO}$	-60	-45	-45	Volts
Collector-Emitter Voltage	$V_{CEO}$	-50	-30	-30	Volts
Emitter-Base Voltage	$V_{EBO}$	-5	-5	-5	Volts
Continuous Collector Current	$I_C$	-200	-200	-200	mA
Power Dissipation (at $T_{amb} = 25^\circ C$ )	$P_{tot}$	500	500	500	mW
Operating and Storage Temperature Range		-55 to +175			$^\circ C$

# ZTX212 Series

CHARACTERISTICS (at 25°C ambient temperature unless otherwise stated).

Parameter	Symbol	ZTX212		ZTX213		ZTX214		Unit	Conditions
		Min.	Max.	Min.	Max.	Min.	Max.		
Collector-emitter saturation voltage	$V_{CE(sat)}$	—	-0.25	—	-0.25	—	-0.25	V	$I_C = -10 \text{ mA}$ $I_B = -0.5 \text{ mA}^*$ $I_C = -100 \text{ mA}$ $I_B = -5.0 \text{ mA}^*$
		—	-0.6	—	-0.6	—	-0.6	V	
Collector-base cut off current	$I_{CBO}$	—	-15	—	-15	—	-15	nA	$V_{CB} = -30V$
Collector-emitter breakdown voltage	$V_{(BR)CEO}$	-50	—	-30	—	-30	—	V	$I_C = -2 \text{ mA}$ $I_B = 0$
Emitter-base breakdown voltage	$V_{(BR)EBO}$	-5	—	-5	—	-5	—	V	$I_E = -10 \mu\text{A}$ $I_C = 0$
Collector-base breakdown voltage	$V_{(BR)CBO}$	-60	—	-45	—	-45	—	V	$I_C = -10 \mu\text{A}$ $I_E = 0$
Static forward current transfer ratio	$h_{FE}$	40	—	40	—	100	—		$I_C = -10 \mu\text{A}$ $V_{CE} = -5V$ $I_C = -2 \text{ mA}$ $V_{CE} = -5V$
		60	400	80	550	140	550		
		125	250	125	250	—	—		
		200	400	200	400	200	400		
Group A	—	—	350	550	350	550			
Group B	—	—	—	—	120	—		$I_C = -100 \text{ mA}^*$ $V_{CE} = -5V$	
Group C	—	—	—	—	—	—			
Transition frequency	$f_T$	200	—	200	—	200	—	MHz	$I_C = -10 \text{ mA}$ $V_{CE} = -5V$ $f = 100 \text{ MHz}$
Output capacitance	$C_{obo}$	—	10	—	10	—	10	pF	$V_{CB} = -10V$ $I_E = 0$ $f = 1 \text{ MHz}$
Noise figure	N	—	10	—	10	—	—	dB	$V_{CE} = -5V$ $I_C = -200 \mu\text{A}$ $R_g = 2k\Omega$ $f = 1 \text{ kHz}$ $\Delta f = 200 \text{ Hz}$
Wide band noise figure		—	—	—	—	—	2	dB	$V_{CE} = -5V$ $I_C = -200 \mu\text{A}$ $R_g = 2k\Omega$ $f = 30 \text{ Hz to } 15 \text{ kHz}$ at -3 dB points

\*Measured under pulsed conditions. Pulse width = 300  $\mu\text{s}$ . Duty cycle  $\leq 2\%$ .

# ZTX212 Series

## DERATING CURVE

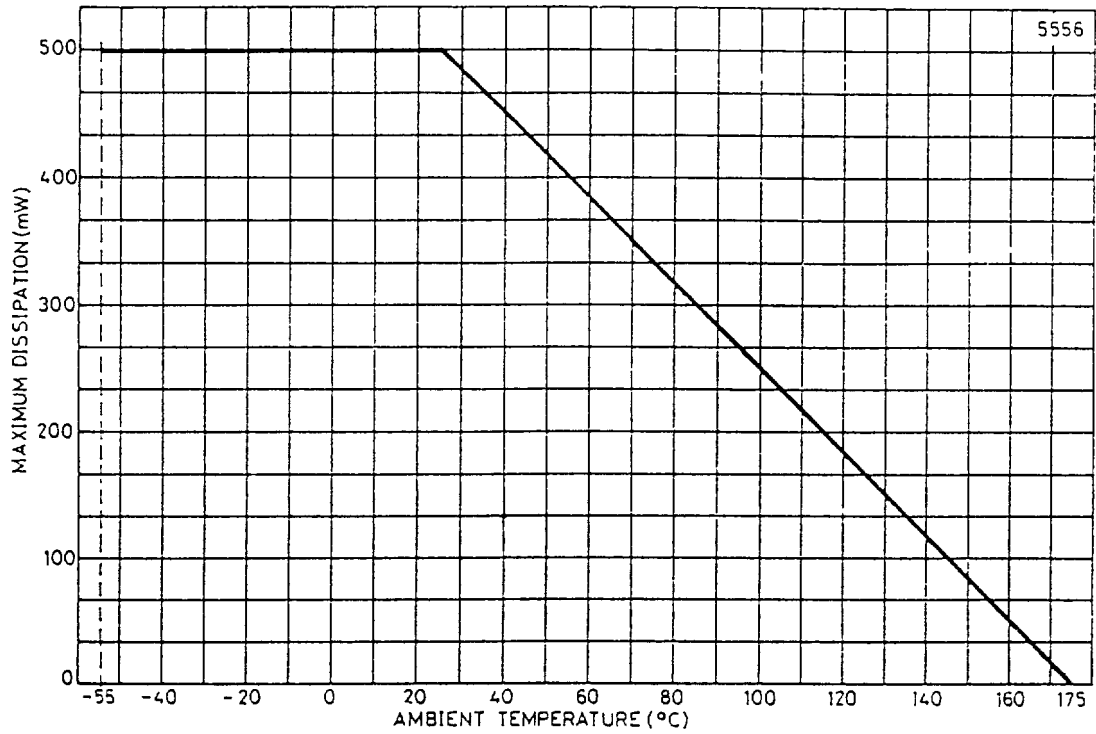

# ZTX212 Series

## LEAD CONFIGURATIONS

Devices can be ordered with the following lead configurations by adding the indicated suffix to the part number.

