



UM95088

Tone Dialer

PRELIMINARY

Features

- Wide Supply Voltage 1.8 ~ 5.5V
- Ceramic oscillator (480K ceramic resonator)
- Fully debounced scanning keyboard
- Minimum tone duration: 73 mS
- Very low tone distortion, less than 1% in band
- On chip power on reset
- Single tone output mode
- Low standby and operating power
- All pins protected against ESD and latch-up
- Low frequency error: max + 0.3%

General Description

The UM95088 DTMF generator is specifically designed to implement a dual tone telephone dialing system in applications requiring fixed supply operation and high stability tone output level, making it well suited for electronic telephone applications. The device can serve as an interface directly to a standard XY matrix telephone keyboard and operates directly from the telephone lines. All necessary dual-tone frequencies are derived from either the widely used 480 KHz ceramic resonator which pro-

vides high accuracy and stability. The required sinusoidal waveform for the individual tones is digitally synthesized on the chip. The waveform so generated has low total harmonic distortion. With the built-in minimum tone duration function, an adaptive solution for fast dialling/short DTMF output is achieved. A reliable power on reset circuit guaranteed proper function under variety of power supply condition.

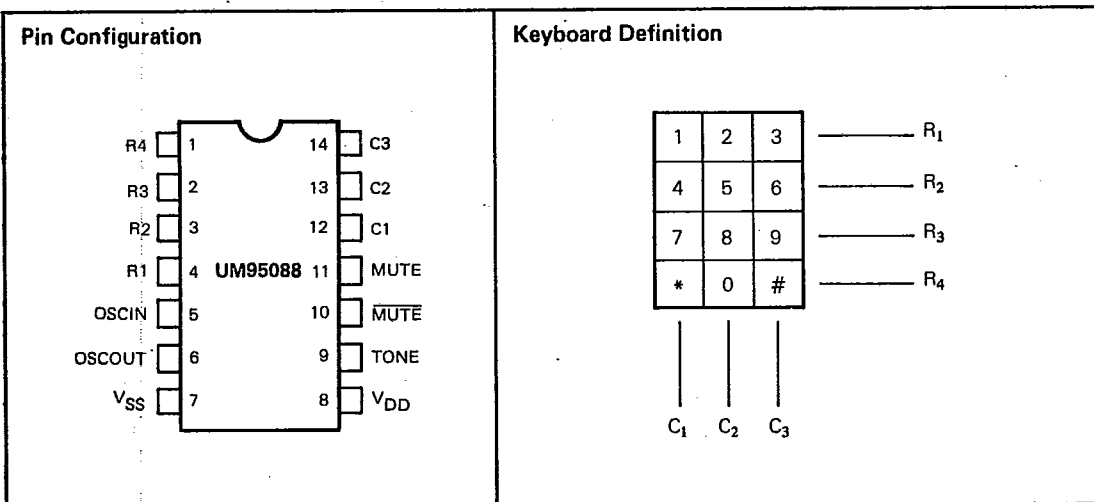

9325812 UNITED MICROELECTRONICS

92D 00418

DT-75-07-07



UM95088

Absolute Maximum Ratings*

***Comments**

Power Supply Voltage ($V_{DD} - V_{SS}$) . . . -0.3V to +6.0V
 Operating Temperature (Top) -20°C to +70°C
 Storage Temperature (Tstg) -55°C to +150°C
 Applied Voltage on Any Pin (V_{IN})
 $V_{SS} - 0.3 \leq V_{IN} \leq V_{DD} + 0.3$

Stresses above those listed under "Absolute Maximum Ratings" may cause permanent damage to the device. This is a stress rating only and functional operation of the device at these or any other conditions above those indicated in the operational sections of this specification is not implied.

Electrical Characteristics

($V_{DD} - V_{SS} = 3.5V$, $F_{osc} = 480$ KHz, $T_{op} = 25^\circ C$, unless otherwise specified.)

Parameter	Symol	Min.	Typ.	Max.	Units	Conditions	
Operating Voltage	V_{DD}	1.8		5.5	V		
Operating Current	I_{DD}		0.7		mA	Oscillator running, all outputs unloaded.	
Standby Current	I_{DD1}		5		μA	$V_{DD} = 2.0V$	all outputs unloaded.
	I_{DD2}		10		μA	$V_{DD} = 3.5V$	
OUTPUT SINK CURRENT							
MUTE, MUTE	I_{OL1}	0.5			mA	$V_{DD} = 2.0V$	$V_{OL} = 0.5V$
	I_{OL2}	1.0			mA	$V_{DD} = 3.5V$	
OUTPUT SOURCE CURRENT							
MUTE	I_{OH1}	0.2			mA	$V_{DD} = 2.0V$	$V_{OH} = 1.5V$
	I_{OH2}	0.5			mA	$V_{DD} = 3.5V$	$V_{OH} = 3.0V$
Single Column Tone Output Amplitude	V_{PP1}		520		mV	$V_{DD} = 2.0V$	Rload = 15 Kohm
	V_{PP2}		910		mV	$V_{DD} = 3.5V$	
Valley of Single Row/Column Tone	V_{vally}		0.45		V_{DD}	Rload = 15 Kohm	
Single Row Tone Output Amplitude	V_{PP1}		390		mV	$V_{DD} = 2.0V$	Rload = 15 Kohm
	V_{PP2}		680		mV	$V_{DD} = 3.5V$	
Distortion		%DIS		5			



UM95088

Table 1. Comparison of Specified vs Actual Tone Frequencies Generated by the UM95088

Output Frequency (Hz)		% Error*
Specified	Actual	
697 (Row 1)	695.65	-0.19
770 (Row 2)	769.23	-0.10
852 (Row 3)	851.06	-0.11
941 (Row 4)	941.18	+0.02
1,209 (Column 1)	1,212.12	+0.26
1,336 (Column 2)	1,333.33	-0.20
1,477 (Column 3)	1,481.48	+0.30

*: % Error does not include oscillator drift.

The UM95088 DTMF generator is well designed with an 8-Level, 16-Segment, 1/2 V_{DD} reference voltage structure. The THD (Total Harmonic Distortion) of the UM95088 DTMF output is less than 1% in-band. The Temperature Coefficient of the DTMF output amplitude is balanced to zero from the adaptive DTMF generator structure.

The output strength of the Column Tone is pre-emphasized 2.5 dB than the Row Tone.

The typical equivalent output impedance of this DTMF generator is 1.5K ohm.

Pin Description

Keyboard

These are the keyboard input pins of the UM95088. The

Timing Diagram

(When power supply is ready)

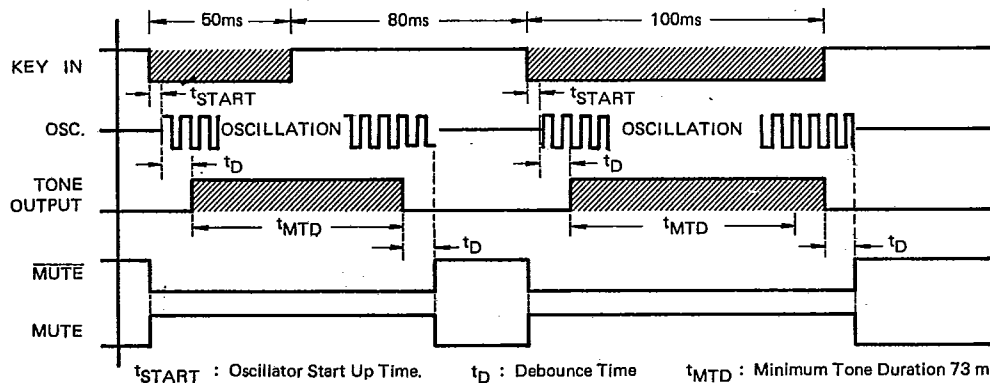

output of the Column pins C₁, C₂, C₃ are high and the output of the Row pins R₁, R₂, R₃, R₄ and low in the stand-by state. Each column has a pull-up resistor (120 K ohm typically). A logic low is presented at the connected row and column pins.

Debouncing circuit is provided (10 ms typically). Multiple keys – Single Tone output is provided for testing purpose.

Oscillator (OSCIN, OSCOUT)

The oscillator is designed to operate at a full range of supply voltage (1.8 – 5.5V) with very good voltage stability for ceramic resonator. The oscillator is activated upon any key-down. Start up time is max. 5 ms at V_{DD} = 3.5V.

Tone Output (TONE)

This is the DTMF output pin. The output impedance is 1.5 K ohm typically. This pin is forced to V_{SS} when there is no output. The column tone to row tone ratio is 2.5 dB typically. A single tone is accessed by depressing two or more keys in a row for appropriate row tone; and two or more keys in a column for appropriate column tone.

MUTE Output

This is an inverter output. This output is activated during tone output. The source/sink capability is 0.2/0.5 mA at 2V supply voltage and 0.5V drain voltage fall.

MUTE Output

This is an open drain output device. This output is activated during tone output. This output can sink the current from higher voltage source (> V_{DD}) directly.

9325812 UNITED MICROELECTRONICS

92D 00420

D 7-75-07-07



UM95088

A Low Cost Touch Tone Telephone Application Example

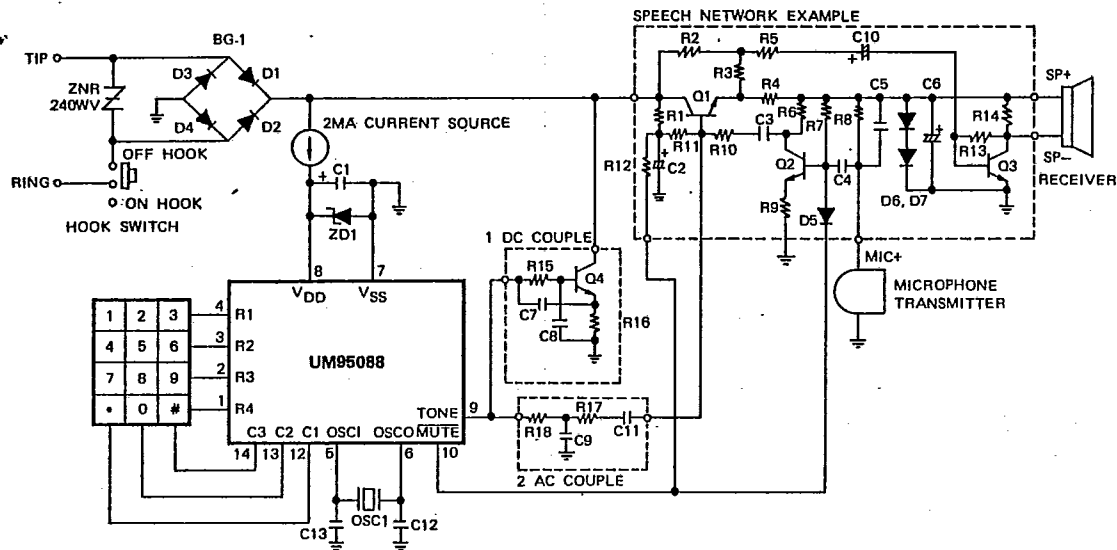

Parts List

Diode

D₁ ~ D₄: IN4004x4
D₅, D₆, D₇: IN4148x3

Transistor

Q₁ ~ Q₄: 2SC945x4

Resistor:

R1 : 4K7
R2 : 3K3
R3 : 180Ω
R4 : 22Ω
R5 : 1K2
R6 : 1K2
R7 : 680K
R8 : 2K2
R9 : 75Ω
R10: 4K7
R11: 22K
R12: 10K
R13: 10K
R14: 1K2
R15: 1K2
R16: 220Ω
R17: 10K
R18: 1K2

Capacitor

C1 : 10μF/16WV
C2 : 10μF/16WV
C3 : 0.1μF/50WV
C4 : 0.033μF/50WV
C5 : 0.033μF/50WV
C6 : 47μF/10WV
C7 : 0.033μF/50WV
C8 : 0.033μF/50WV
C9 : 0.0033μF/50WV
C10: 1μF/10WV
C11: 0.033μF/50WV
C12: 100PF
C13: 100PF

Oscillator

OSC1: 480KHz Ceramic Resonator

High Voltage Protector

ZNR: 240WV/1W Varistor

Zener Diode

ZDI: 3.9WV/0.5W ZD

Receiver

100 OHM receiver

Transmitter

ECM mic.

