

	<h1 style="margin: 0;">AK5358</h1> <h2 style="margin: 0;">96kHz 24-Bit $\Delta\Sigma$ ADC</h2>
---	---

GENERAL DESCRIPTION

The AK5358 is a stereo A/D Converter with wide sampling rate of 8kHz ~ 96kHz and is suitable for consumer to professional audio system. The AK5358 achieves high accuracy and low cost by using Enhanced dual bit $\Delta\Sigma$ techniques. The AK5358 requires no external components because the analog inputs are single-ended. The audio interface has two formats (MSB justified, I²S) and can correspond to various systems like DTV, DVR and AV Receiver.

FEATURES

- Linear Phase Digital Anti-Alias Filtering
- Single-ended Input
- Digital HPF for DC-Offset cancel
- S/(N+D): 92dB
- DR: 102dB
- S/N: 102dB
- Sampling Rate Ranging from 8kHz to 96kHz
- Master Clock:
 - 256fs/384fs/512fs/768fs (8kHz ~ 48kHz)
 - 256fs/384fs (48kHz ~ 96kHz)
- Input level: CMOS
- Master / Slave Mode
- Audio Interface: 24bit MSB justified / I²S selectable
- Power Supply: 4.5 ~ 5.5V (Analog), 2.7 ~ 3.6V (Digital)
- Ta = -20 ~ 85°C
- Small 16pin TSSOP Package
- AK5357/59/81 Pin-compatible

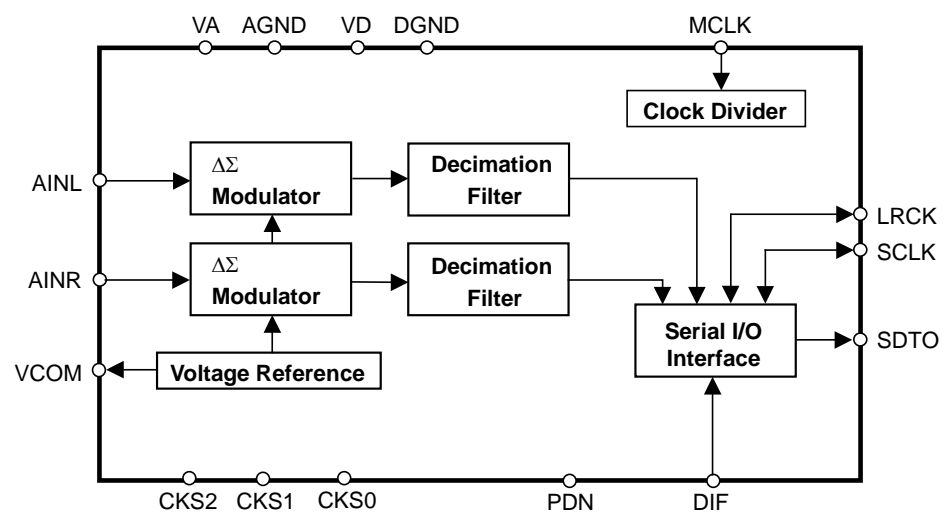

■ Ordering Guide

AK5358ET
AKD5358

-20 ~ +85°C
Evaluation Board for AK5358

16pin TSSOP (0.65mm pitch)

■ Pin Layout

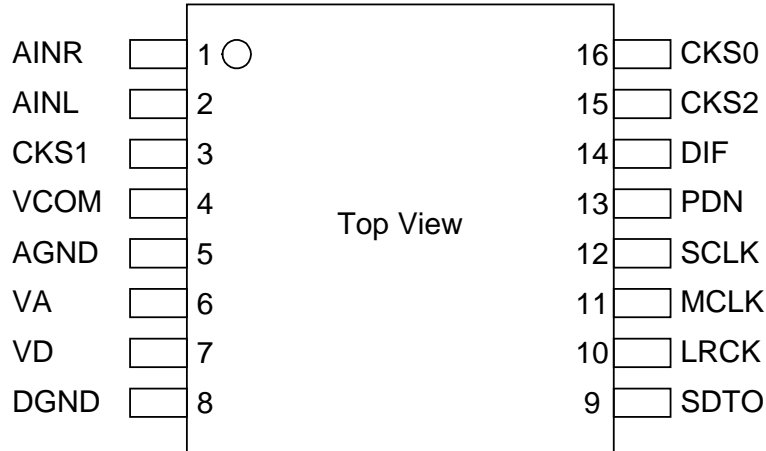

■ Compatibility with AK5357, AK5359 and AK5381

	AK5357	AK5358	AK5381	AK5359
fs	4kHz to 96kHz	8kHz to 96kHz	4kHz to 96kHz	8kHz to 216kHz
S/(N+D)	88dB	92dB	96dB	94dB
DR	102dB	102dB	106dB	102dB
VIH@TTL Level Mode	2.2V	2.2V	2.4V	Not Available
VA (Analog Supply)	2.7 to 5.5V	4.5 to 5.5V	4.5 to 5.5V	4.5 to 5.5V
VD (Digital Supply)	2.7 to 5.5V	2.7 to 3.6V	2.7 to 5.5V 3.0 to 5.5V @96kHz	3.0 to 5.5V
HPF Disable	Available	Not Available	Available	Available
Operating Temperature	ET: -20 ~ +85°C VT: -40 ~ +85°C	ET: -20 ~ +85°C	ET: -20 ~ +85°C VT: -40 ~ +85°C XT: -40 ~ +85°C	ET: -20 ~ +85°C VT: -40 ~ +85°C

PIN / FUNCTION			
No.	Pin Name	I/O	Function
1	AINR	I	Rch Analog Input Pin
2	AINL	I	Lch Analog Input Pin
3	CKS1	I	Mode Select 1 Pin
4	VCOM	O	Common Voltage Output Pin, VA/2 Bias voltage of ADC input.
5	AGND	-	Analog Ground Pin
6	VA	-	Analog Power Supply Pin, 4.5 ~ 5.5V
7	VD	-	Digital Power Supply Pin, 2.7 ~ 3.6V
8	DGND	-	Digital Ground Pin
9	SDTO	O	Audio Serial Data Output Pin “L” Output at Power-down mode.
10	LRCK	I/O	Output Channel Clock Pin “L” Output in Master Mode at Power-down mode.
11	MCLK	I	Master Clock Input Pin
12	SCLK	I/O	Audio Serial Data Clock Pin “L” Output in Master Mode at Power-down mode.
13	PDN	I	Power Down Mode & Reset Pin “H”: Power up, “L”: Power down & Reset The AK5358 must be reset once upon power-up.
14	DIF	I	Audio Interface Format Pin “H”: 24bit I ² S Compatible, “L”: 24bit MSB justified
15	CKS2	I	Mode Select 2 Pin
16	CKS0	I	Mode Select 0 Pin

Note: All input pins except analog input pins (AINR, AINL) should not be left floating.

■ Handling of Unused Pin

The unused input pins should be processed appropriately as below.

Classification	Pin Name	Setting
Analog	AINL	This pin should be open.
	AINR	This pin should be open.

ABSOLUTE MAXIMUM RATINGS

(AGND, DGND=0V; Note 1)

Parameter		Symbol	min	max	Units
Power Supplies:	Analog	VA	-0.3	6.0	V
	Digital	VD	-0.3	4.6	V
	AGND – DGND (Note 2)	ΔGND	-	0.3	V
Input Current, Any Pin Except Supplies		IIN	-	±10	mA
Analog Input Voltage (AINL, AINR, CKS1 pins)		VINA	-0.3	VA+0.3	V
Digital Input Voltage (Note 3)		VIND	-0.3	VD+0.3	V
Ambient Temperature (powered applied)		Ta	-20	85	°C
Storage Temperature		Tstg	-65	150	°C

Note 1. All voltages with respect to ground.

Note 2. AGND and DGND must be connected to the same analog ground plane.

Note 3. . PDN, DIF, MCLK, SCLK, LRCK, CKS0, CKS2 pins

WARNING: Operation at or beyond these limits may result in permanent damage to the device.

Normal operation is not guaranteed at these extremes.

RECOMMENDED OPERATING CONDITIONS

(AGND, DGND=0V; Note 1)

Parameter		Symbol	min	typ	max	Units
Power Supplies (Note 4)	Analog	VA	4.5	5.0	5.5	V
	Digital	VD	2.7	3.3	3.6	V

Note 4. The power up sequence between VA and VD is not critical.

WARNING: AKM assumes no responsibility for the usage beyond the conditions in this datasheet.

ANALOG CHARACTERISTICS

(Ta=25°C; VA=5.0V, VD=3.3V; AGND=DGND=0V; fs=48kHz, 96kHz; SCLK=64fs; Signal Frequency=1kHz; 24bit Data; Measurement frequency=20Hz ~ 20kHz at fs=48kHz, 40Hz ~ 40kHz at fs=96kHz; unless otherwise specified)

Parameter	min	typ	max	Units			
ADC Analog Input Characteristics:							
Resolution			24	Bits			
Input Voltage	(Note 5)		2.7	3.0	3.3	V _{pp}	
S/(N+D)	fs=48kHz BW=20kHz	-1dBFS	82	92		dB	
		-60dBFS	-	39		dB	
	fs=96kHz BW=40kHz	-1dBFS	-	90		dB	
		-60dBFS	-	38		dB	
DR	(-60dBFS, A-weighted)		94	102		dB	
S/N	(A-weighted)		94	102		dB	
Input Resistance	fs=48kHz		13	20		kΩ	
	fs=96kHz		9	14		kΩ	
Interchannel Isolation			90	110		dB	
Interchannel Gain Mismatch				0.1	0.5	dB	
Gain Drift				100	-	ppm/°C	
Power Supply Rejection			(Note 6)		-	50	dB
Power Supplies							
Power Supply Current							
Normal Operation (PDN pin = "H")							
VA				12	18	mA	
VD		(fs=48kHz)		3	5	mA	
VD		(fs=96kHz)		6	9	mA	
Power down mode (PDN pin = "L") (Note 7)							
VA+VD				10	100	μA	

Note 5. This value is the full scale (0dB) of the input voltage. Input voltage is proportional to VA voltage.

$$V_{in} = 0.6 \times V_A \text{ (V}_{pp}\text{)}$$

Note 6. PSR is applied to VA and VD with 1kHz, 50mV_{pp}.

Note 7. All digital input pins and CKS1 pin are held VD or DGND.

FILTER CHARACTERISTICS (fs=48kHz)						
(Ta=-20°C ~ 85°C; VA=4.5 ~ 5.5V; VD=2.7 ~ 3.6V)						
Parameter		Symbol	min	typ	max	Units
ADC Digital Filter (Decimation LPF):						
Passband (Note 8)	±0.1dB	PB	0		18.9	kHz
	-0.2dB		-	20.0	-	kHz
	-3.0dB		-	23.0	-	kHz
Stopband		SB	28			kHz
Passband Ripple		PR			±0.04	dB
Stopband Attenuation		SA	68			dB
Group Delay Distortion		ΔGD		0		μs
Group Delay (Note 9)		GD		16		1/fs
ADC Digital Filter (HPF):						
Frequency Response (Note 8)	-3dB	FR		1.0		Hz
	-0.1dB			6.5		Hz

FILTER CHARACTERISTICS (fs=96kHz)						
(Ta=-20°C ~ 85°C; VA=4.5 ~ 5.5V; VD=2.7 ~ 3.6V)						
Parameter		Symbol	min	typ	max	Units
ADC Digital Filter (Decimation LPF):						
Passband (Note 8)	±0.1dB	PB	0		37.8	kHz
	-0.2dB		-	40.0	-	kHz
	-3.0dB		-	46.0	-	kHz
Stopband		SB	56			kHz
Passband Ripple		PR			±0.04	dB
Stopband Attenuation		SA	68			dB
Group Delay Distortion		ΔGD		0		μs
Group Delay (Note 9)		GD		16		1/fs
ADC Digital Filter (HPF):						
Frequency Response (Note 8)	-3dB	FR		2.0		Hz
	-0.1dB			13.0		Hz

Note 8. The passband and stopband frequencies scale with fs.

For example, PB=18.9kHz@±0.1dB is $0.39375 \times fs$.

Note 9. The calculated delay time induced by digital filtering. This time is from the input of an analog signal to the setting of 24bit data both channels to the ADC output register for ADC.

DC CHARACTERISTICS (CMOS Level Mode)

(Ta=-20°C ~ 85°C; VA=4.5 ~ 5.5V; VD=2.7 ~ 3.6V)

Parameter	Symbol	min	typ	max	Units
High-Level Input Voltage	VIH	70%VD	-	-	V
Low-Level Input Voltage	VIL	-	-	30%VD	V
High-Level Output Voltage (Iout=-1mA)	VOH	VD-0.5	-	-	V
Low-Level Output Voltage (Iout=1mA)	VOL	-	-	0.5	V
Input Leakage Current	Iin	-	-	±10	μA

SWITCHING CHARACTERISTICS						
(Ta=-20°C ~ 85°C; VA=4.5 ~ 5.5V; VD=2.7 ~ 3.6V; C _L =20pF)						
Parameter	Symbol	min	typ	max	Units	
Master Clock Timing						
512fs, 256fs Frequency	fCLK	2.048		24.576	MHz	
Pulse Width Low	tCLKL	16			ns	
Pulse Width High	tCLKH	16			ns	
768fs, 384fs Frequency	fCLK	3.072		36.864	MHz	
Pulse Width Low	tCLKL	10.5			ns	
Pulse Width High	tCLKH	10.5			ns	
LRCK Frequency						
	fs	8		96	kHz	
Duty Cycle		45		55	%	
	Slave mode					
	Master mode		50		%	
Audio Interface Timing						
Slave mode						
SCLK Period	tSCK	160			ns	
SCLK Pulse Width Low	tSCKL	65			ns	
Pulse Width High	tSCKH	65			ns	
LRCK Edge to SCLK “↑” (Note 10)	tLRSH	30			ns	
SCLK “↑” to LRCK Edge (Note 10)	tSHLR	30			ns	
LRCK to SDTO (MSB) (Except I ² S mode)	tLRS			35	ns	
SCLK “↓” to SDTO	tSSD			35	ns	
Master mode						
SCLK Frequency	fSCK		64fs		Hz	
SCLK Duty	dSCK		50		%	
SCLK “↓” to LRCK	tMSLR	-20		20	ns	
SCLK “↓” to SDTO	tSSD	-20		35	ns	
Reset Timing						
PDN Pulse Width (Note 11)	tPD	150			ns	
PDN “↑” to SDTO valid at Slave Mode (Note 12)	tPDV			4132	1/fs	
PDN “↑” to SDTO valid at Master Mode (Note 12)	tPDV			4129	1/fs	

Note 10. SCLK rising edge must not occur at the same time as LRCK edge.

Note 11. The AK5358 can be reset by bringing the PDN pin = “L”.

Note 12. This cycle is the number of LRCK rising edges from the PDN pin = “H”.

■ Timing Diagram

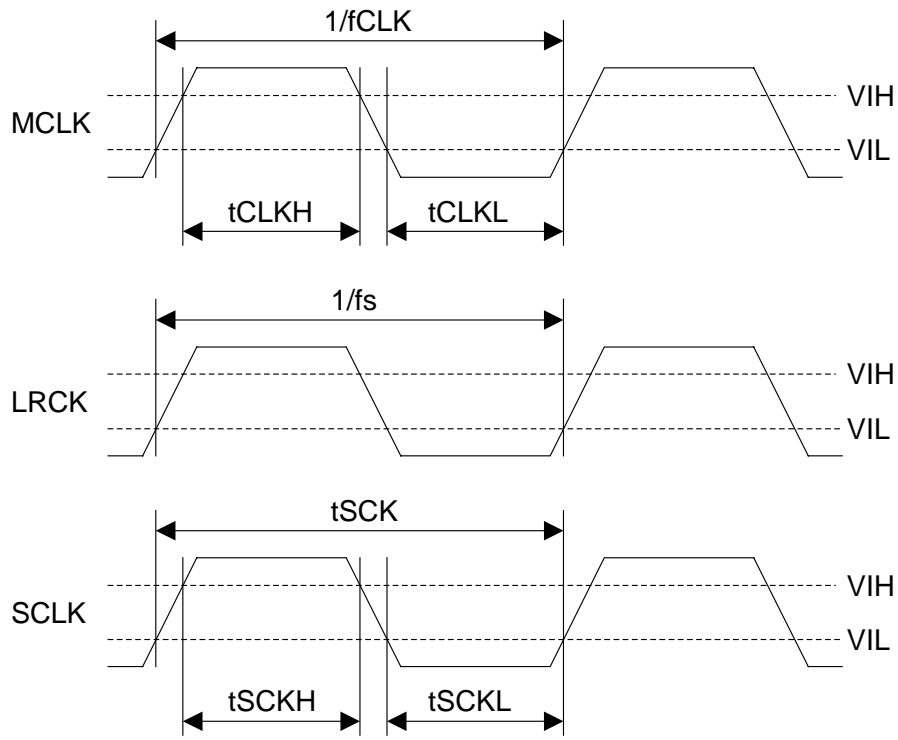

Clock Timing

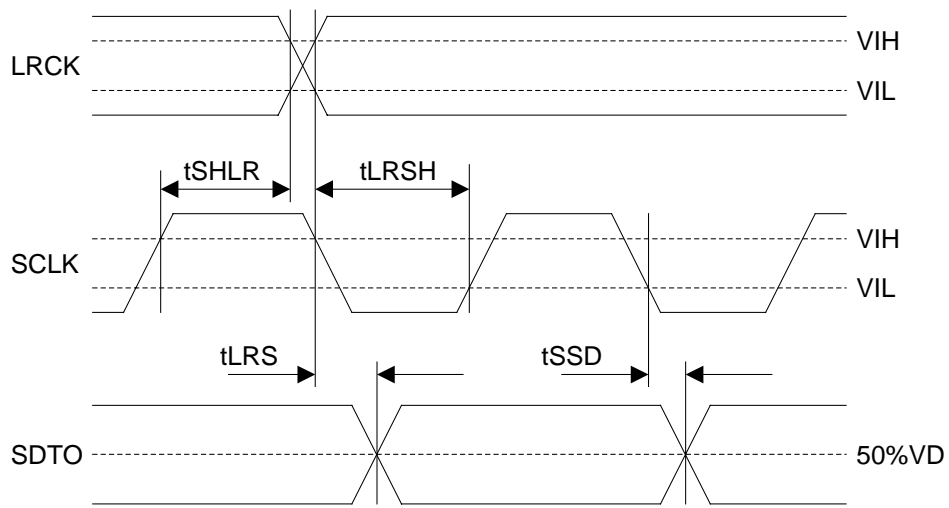

Audio Interface Timing (Slave mode)

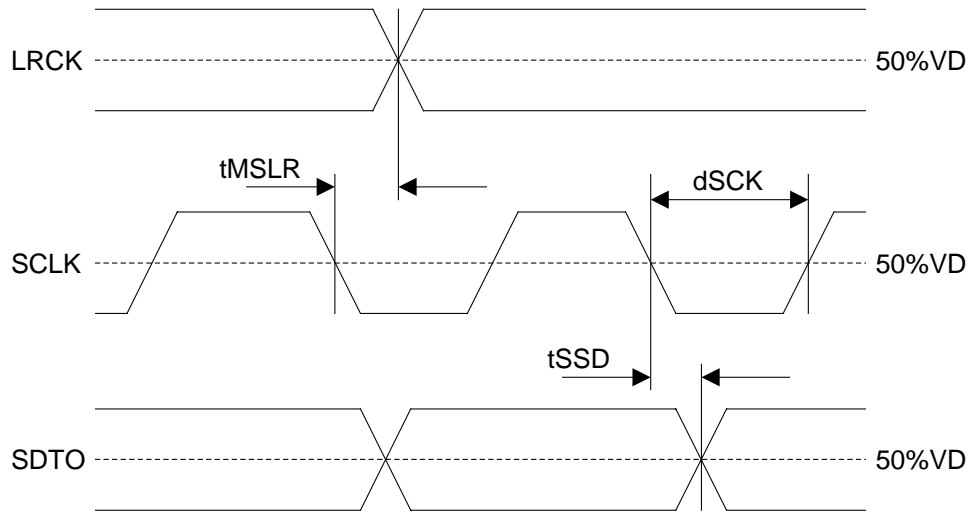

Audio Interface Timing (Master mode)

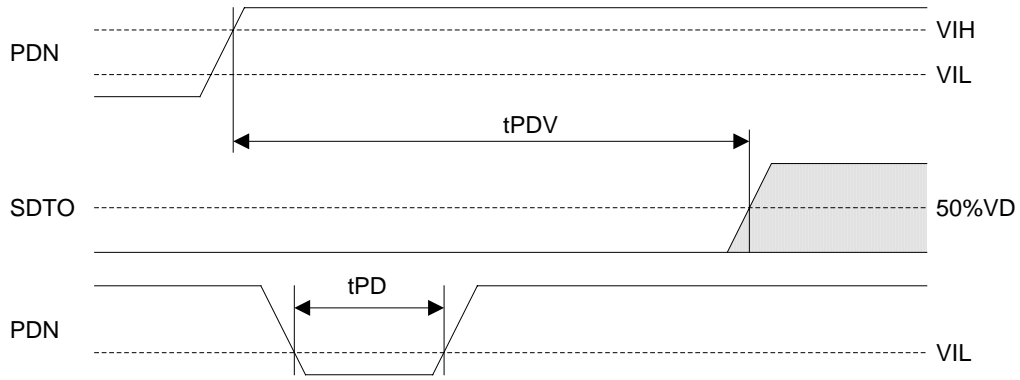

Power Down & Reset Timing

OPERATION OVERVIEW

■ System Clock

MCLK, SCLK and LRCK (fs) clocks are required in slave mode. The LRCK clock input must be synchronized with MCLK, however the phase is not critical. Table 1 shows the relationship of typical sampling frequency and the system clock frequency. MCLK frequency, SCLK frequency and master/slave are selected by CKS2-0 pins as shown in Table 2.

All external clocks (MCLK, SCLK and LRCK) must be present unless PDN pin = "L". If these clocks are not provided, the AK5358 may draw excess current due to its use of internal dynamically refreshed logic. If the external clocks are not present, place the AK5358 in power-down mode (PDN pin = "L"). In master mode, the master clock (MCLK) must be provided unless PDN pin = "L".

fs	MCLK			
	256fs	384fs	512fs	768fs
32kHz	8.192MHz	12.288MHz	16.384MHz	24.576MHz
44.1kHz	11.2896MHz	16.9344MHz	22.5792MHz	33.8688MHz
48kHz	12.288MHz	18.432MHz	24.576MHz	36.864MHz
96kHz	24.576MHz	36.864MHz	N/A	N/A

Table 1. System Clock Example

Mode	CKS2	CKS1	CKS0	Input Level	Master/Slave	MCLK	SCLK
0	L	L	L	CMOS	Slave	256/384fs (8k≤fs≤96k) 512/768fs (8k≤fs≤48k)	≥ 48fs or 32fs (Note 13)
1	L	L	H			Reserved	
2	L	H	L	CMOS	Master	256fs (8k≤fs≤96k)	64fs
3	L	H	H	CMOS	Master	512fs (8k≤fs≤48k)	64fs
4	H	L	L			Reserved	
5	H	L	H			Reserved	
6	H	H	L	CMOS	Master	384fs (8k≤fs≤96k)	64fs
7	H	H	H	CMOS	Master	768fs (8k≤fs≤48k)	64fs

Table 2. Operation Mode Select

Note 13. SDTO outputs 16bit data at SCLK=32fs.

■ Audio Interface Format

Two kinds of data formats can be chosen with the DIF pin (Table 3). In both modes, the serial data is in MSB first, 2's complement format. The SDTO is clocked out on the falling edge of SCLK. The audio interface supports both master and slave modes. In master mode, SCLK and LRCK are output with the SCLK frequency fixed to 64fs and the LRCK frequency fixed to 1fs.

Mode	DIF pin	SDTO	LRCK	SCLK	Figure
0	L	24bit, MSB justified	H/L	≥ 48fs or 32fs	Figure 1
1	H	24bit, I ² S Compatible	L/H	≥ 48fs or 32fs	Figure 2

Table 3. Audio Interface Format

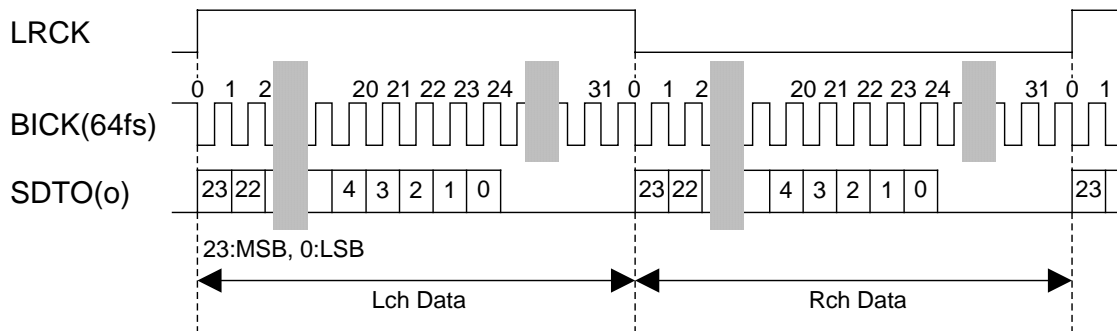

Figure 1. Mode 0 Timing

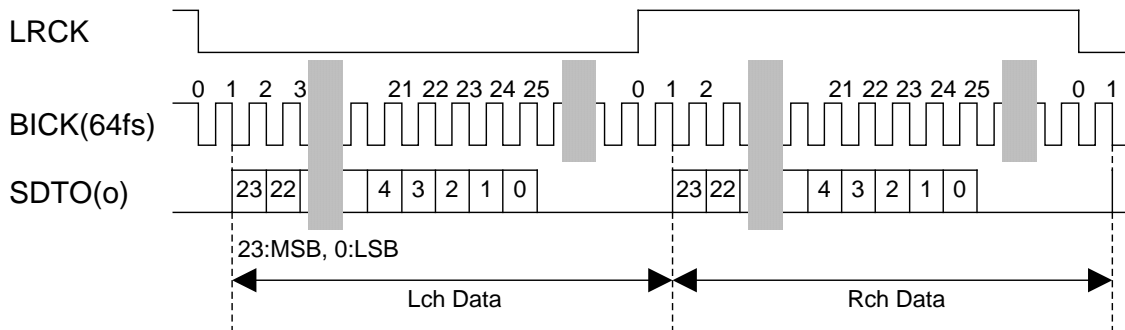

Figure 2. Mode 1 Timing

■ Digital High Pass Filter

The ADC has a digital high pass filter for DC offset cancellation. The cut-off frequency of the HPF is 1.0Hz (@fs=48kHz) and scales with sampling rate (fs).

■ Power down

The AK5358 is placed in the power-down mode by bringing PDN pin “L” and the digital filter is also reset at the same time. This reset should always be done after power-up. In the power-down mode, the VCOM are AGND level. An analog initialization cycle starts after exiting the power-down mode. Therefore, the output data SDTO becomes available after 4129 cycles of LRCK clock in master mode or 4132 cycles of LRCK clock in slave mode. During initialization, the ADC digital data outputs of both channels are forced to a 2’s complement “0”. The ADC outputs settle in the data corresponding to the input signals after the end of initialization (Settling approximately takes the group delay time).

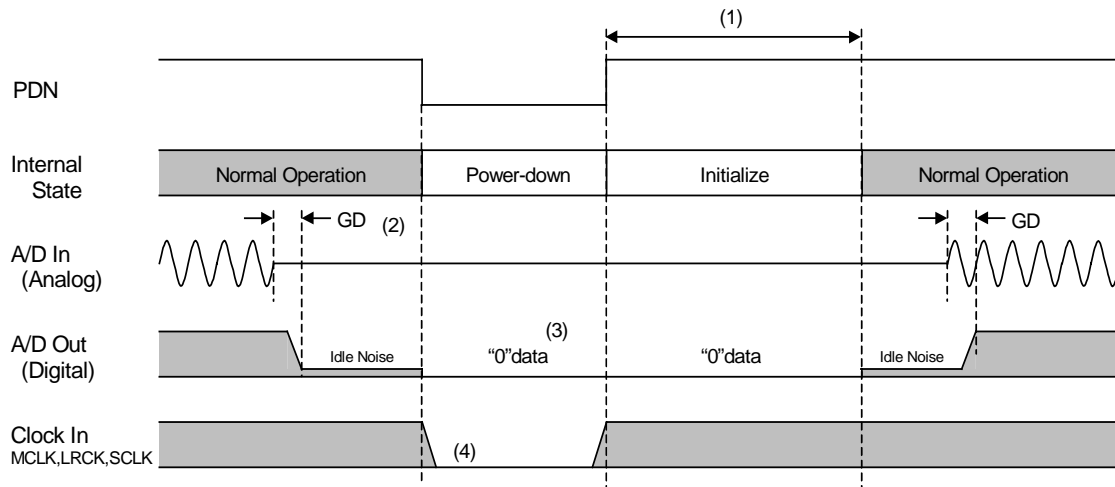

Notes:

- (1) 4132/fs in slave mode and 4129/fs in master mode.
- (2) Digital output corresponding to analog input has the group delay (GD).
- (3) A/D outputs “0” data at the power-down state.
- (4) When the external clocks (MCLK, SCLK and LRCK) are stopped, the AK5358 should be in the power-down state.

Figure 3. Power-down/up sequence example

■ System Reset

The AK5358 should be reset once by bringing PDN pin “L” after power-up. In slave mode, the internal timing starts clocking by the rising edge (falling edge at mode 1) of LRCK after exiting from reset and power down state by MCLK. The AK5358 is power down state until LRCK is input. In master mode, the internal timing starts when MCLK is input.

SYSTEM DESIGN

Figure 4 shows the system connection diagram. An evaluation board is available which demonstrates application circuits, the optimum layout, power supply arrangements and measurement results.

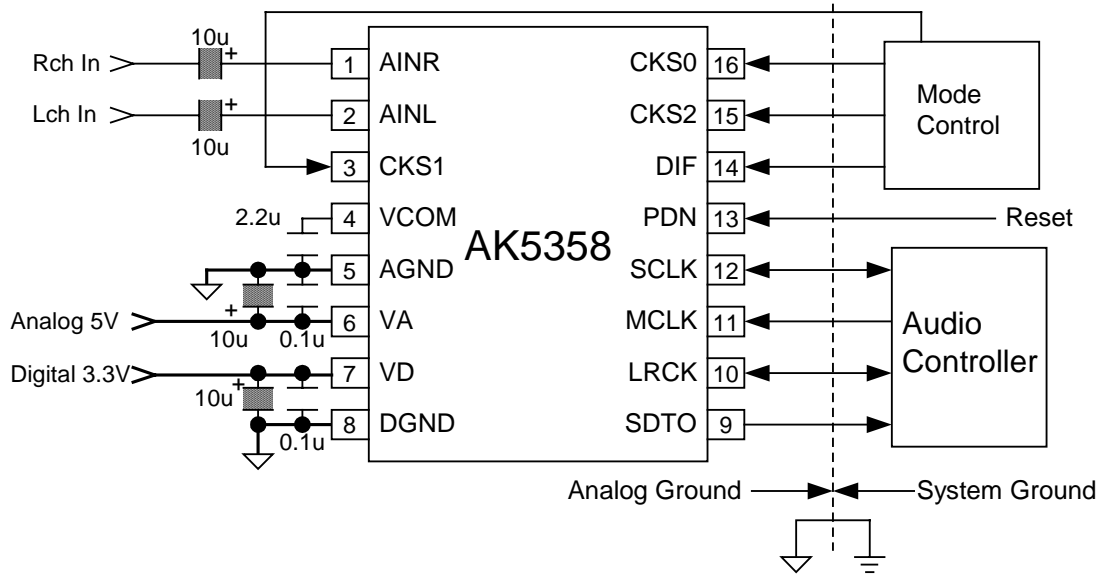

Note:

- AGND and DGND of the AK5358 should be distributed separately from the ground of external digital devices (MPU, DSP etc.).
- All digital input pins should not be left floating.
- The CKS1 pin should be connected to VA or AGND.

Figure 4. Typical Connection Diagram

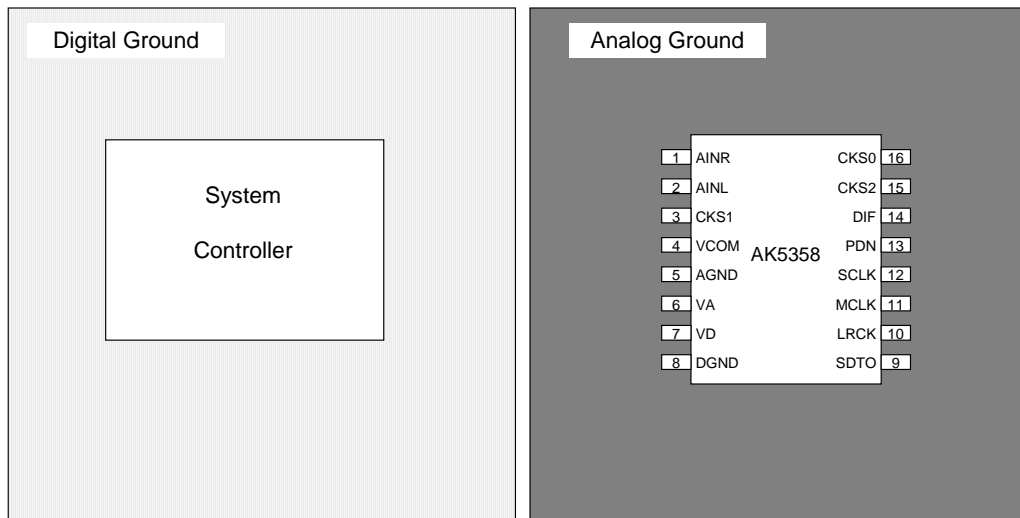

Figure 5. Ground Layout

Note:

- AGND and DGND must be connected to the same analog ground plane.

1. Grounding and Power Supply Decoupling

The AK5358 requires careful attention to power supply and grounding arrangements. Alternatively if VA and VD are supplied separately, the power up sequence is not critical. **AGND and DGND of the AK5358 must be connected to analog ground plane.** System analog ground and digital ground should be connected together near to where the supplies are brought onto the printed circuit board. Decoupling capacitors should be as near to the AK5358 as possible, with the small value ceramic capacitor being the nearest.

2. Voltage Reference

The voltage input to VA sets the analog input range. VCOM are 50% VA and normally connected to AGND with a 0.1 μ F ceramic capacitor. A capacitor 2.2 μ F is attached to VCOM pin. No load current may be drawn from these pins. All signals, especially clocks, should be kept away from the VCOM pin in order to avoid unwanted coupling into the AK5358.

3. Analog Inputs

The ADC inputs are single-ended and internally biased to the common voltage (50% VA) with 20k Ω (typ@fs=48kHz) resistance. The input signal range scales with the supply voltage and nominally 0.6xVA Vpp (typ). The ADC output data format is 2's complement. The internal HPF removes the DC offset.

The AK5358 samples the analog inputs at 64fs (@fs=48kHz). The digital filter rejects noise above the stop band except for multiples of 64fs. The AK5358 includes an anti-aliasing filter (RC filter) to attenuate a noise around 64fs.

PACKAGE

16pin TSSOP (Unit: mm)

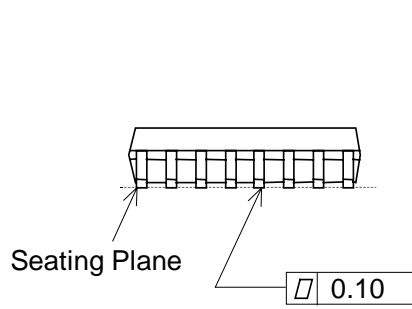
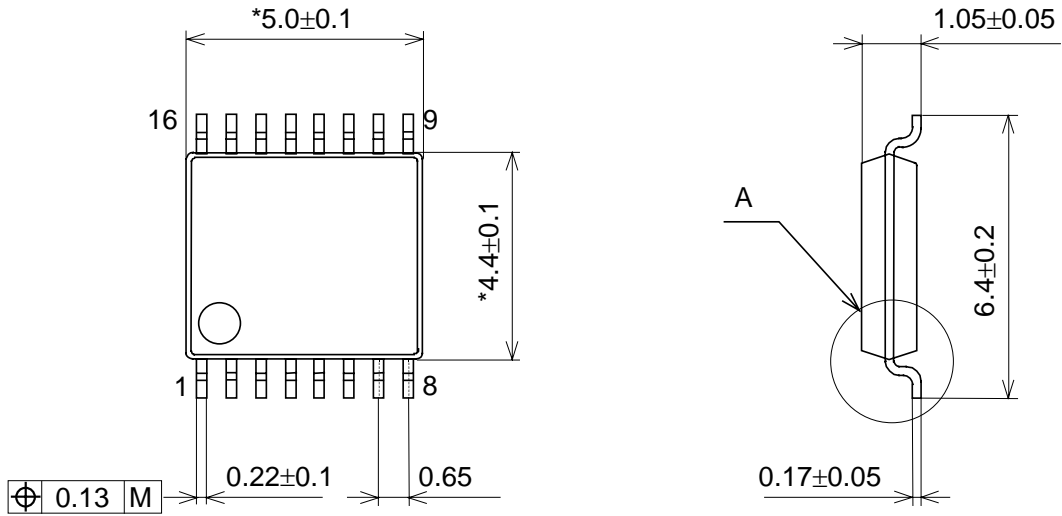

Detail A

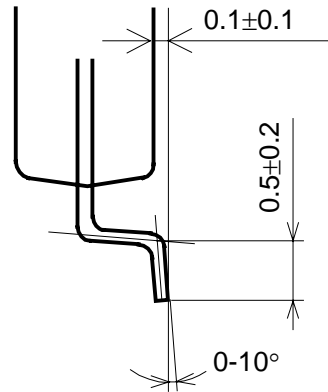

NOTE: Dimension "*" does not include mold flash.

■ Material & Lead finish

- Package molding compound: Epoxy
- Lead frame material: Cu
- Lead frame surface treatment: Solder (Pb free) plate

MARKING

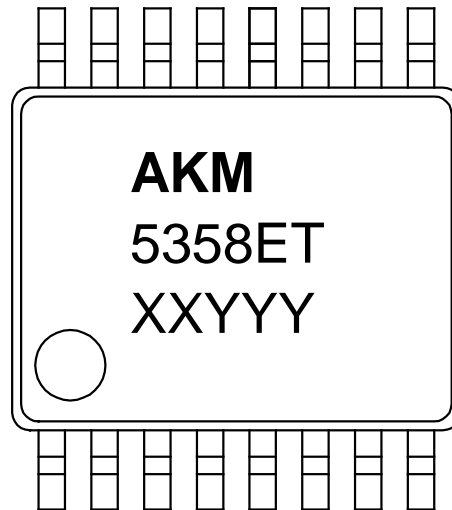

- 1) Pin #1 indication
- 2) Date Code: XXYYYY (5 digits)
 XX: Lot#
 YYY: Date Code
- 3) Marketing Code: 5358ET

Revision History

Date (YY/MM/DD)	Revision	Reason	Page	Contents
05/11/15	00	First Edition		

IMPORTANT NOTICE

- These products and their specifications are subject to change without notice. Before considering any use or application, consult the Asahi Kasei Microsystems Co., Ltd. (AKM) sales office or authorized distributor concerning their current status.
- AKM assumes no liability for infringement of any patent, intellectual property, or other right in the application or use of any information contained herein.
- Any export of these products, or devices or systems containing them, may require an export license or other official approval under the law and regulations of the country of export pertaining to customs and tariffs, currency exchange, or strategic materials.
- AKM products are neither intended nor authorized for use as critical components in any safety, life support, or other hazard related device or system, and AKM assumes no responsibility relating to any such use, except with the express written consent of the Representative Director of AKM. As used here:
 - a. A hazard related device or system is one designed or intended for life support or maintenance of safety or for applications in medicine, aerospace, nuclear energy, or other fields, in which its failure to function or perform may reasonably be expected to result in loss of life or in significant injury or damage to person or property.
 - b. A critical component is one whose failure to function or perform may reasonably be expected to result, whether directly or indirectly, in the loss of the safety or effectiveness of the device or system containing it, and which must therefore meet very high standards of performance and reliability.
- It is the responsibility of the buyer or distributor of an AKM product who distributes, disposes of, or otherwise places the product with a third party to notify that party in advance of the above content and conditions, and the buyer or distributor agrees to assume any and all responsibility and liability for and hold AKM harmless from any and all claims arising from the use of said product in the absence of such notification.