



U8803

CMOS IC

PIR INFRARED REMOTE CONTROL CIRCUIT

DESCRIPTION

The UTC **U8803** is a integrated circuit that design for infrared PIR controlling. It needs only few external components in application circuit. It can be applied as controller of light, electric switching and burglar alarm, and so on.

FEATURES

- *High Noise Immunity
- *Output drivable RELAY or TRIAC.
- *contain two OP amps, gain adjustable.
- *Control time adjustable.
- *steady voltage inside output 3.1 V to drive the PIR directly.
- *Integrate zero cross detect, the AC power supply triggers synchronously, lowering the power supply pollution.

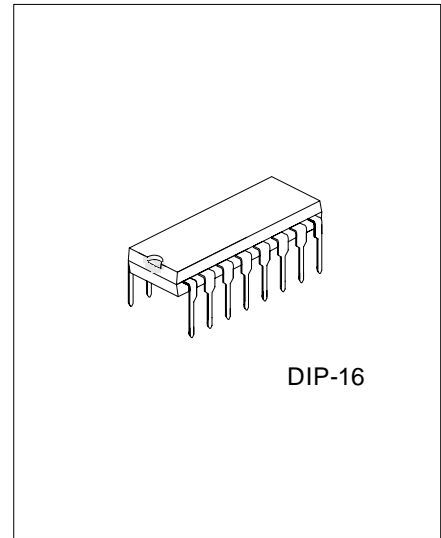

DIP-16

*Pb-free plating product number: U8803L

ORDERING INFORMATION

Order Number		Package	Packing
Normal	Lead Free Plating		
U8803-D16-T	U8803L-D16-T	DIP-16	Tube

<p>U8803L-D16-T</p> <p>(1)Packing Type (2)Package Type (3)Lead Plating</p>	<p>(1) T: Tube (2) D16: DIP-16 (3) L: Lead Free Plating, Blank: Pb/Sn</p>
--	---

■ PIN CONFIGURATION

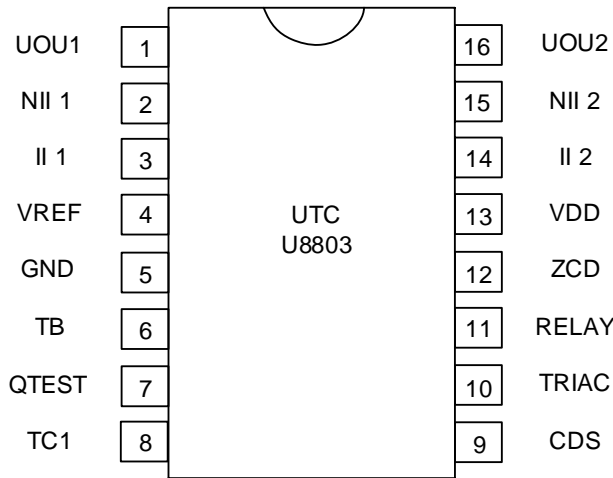

■ PIN DESCRIPTION

PIN NO.	PIN NAME	FUNCTION
1	UOU1	First stage OP amp output
2	N 1	First stage OP amp positive input
3	1	First stage OP amp negative input
4	VREF	Reference voltage
5	GND	Ground
6	TB	Time base for System Clock. The periods $T_{Tb} = (1 \pm 20\%)RC/1.1$
7	QTEST	Test
8	TCI	Timer clock generator. The periods $T_{Tci} = (1 \pm 20\%)RC/1.1$
9	CDS	CDS detect, inhibitory output in the daytime.
10	TRIAC	TRIAC output, active low
11	RELAY	RELAY output, active high
12	ZCD	Detect zero cross of AC line, synchronously pin TRIAC
13	VDD	Power supply
14	2	Second stage OP amp negative input
15	N 2	Second stage OP amp positive input
16	UOU2	Second stage OP amp output

■ BLOCK DIAGRAM

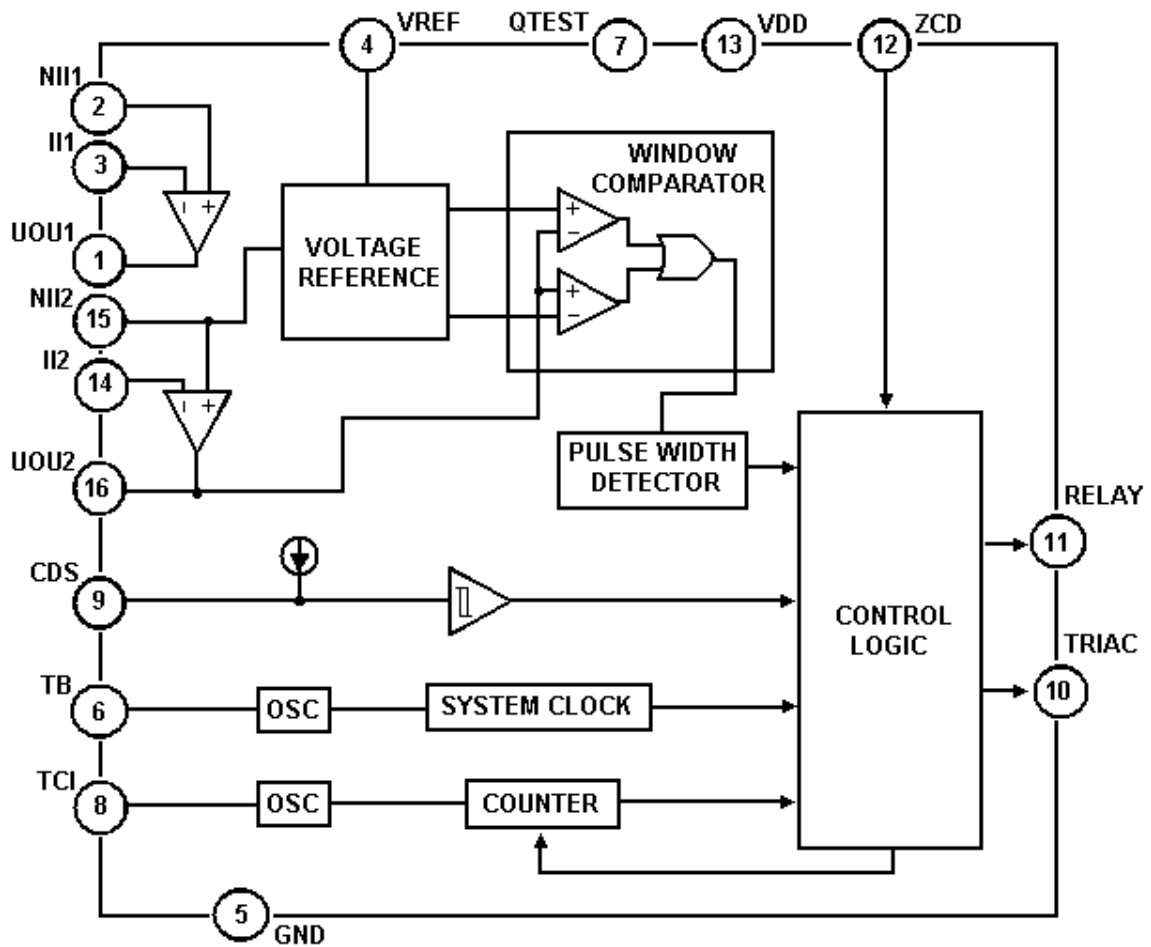

■ FUNCTIONAL DESCRIPTION

1. The PIR amplifier (the first and second stage **Op Amp**) amplifies PIR signal. Its multiple can be adjust through resistance and capacitance outside.
2. If the amplificatory PIR signal voltage is higher than V_H (Typ 1.8V) or lower than V_L (Typ 1.15V), the **Window Comparer** outputs high level.

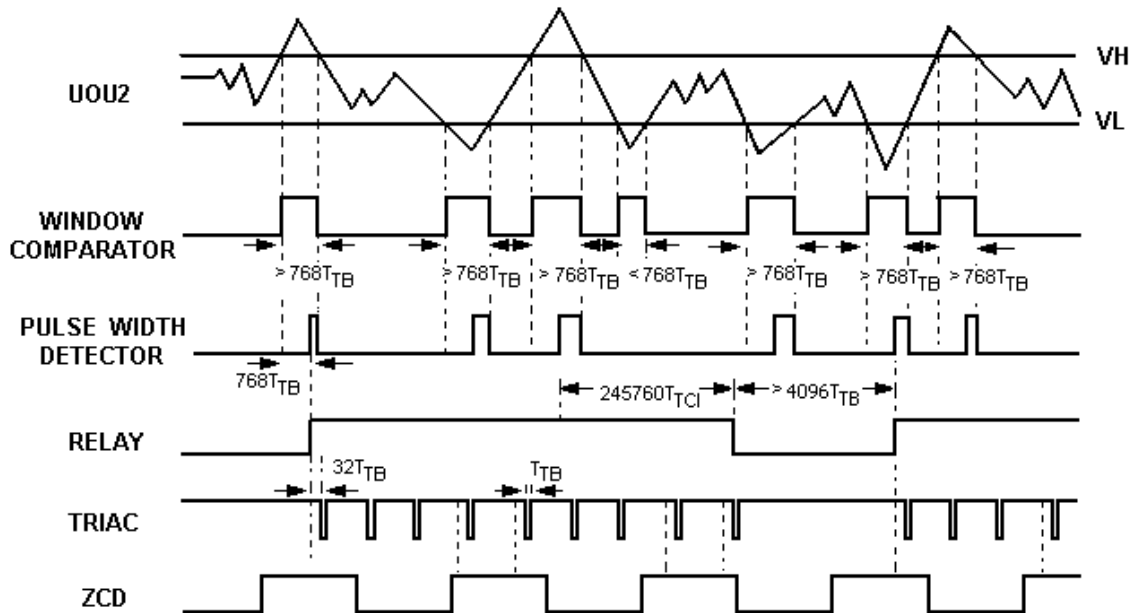

3. The **Pulse Width Detector** detects the **Window Comparer's** pulse width, if the high pulse width is more than $768 * T_{TB}$, this pulse is in effect, and the RELAY or the traic is triggered. Otherwise, it is ignored.
4. When an availability PIR signal is detected, the RELAY outputs high level, and the TRAIC outputs pulse, and the **Counter** starts to count, but if a new availability PIR signal appears, the **Counter** restarts to count. After $245760 * T_{TCI}$, the RELAY and TRIAC stop output.
5. Pin CDS connect a CDS, it can control pin RELAY to keep low level in the daytime.
6. When the AC power crosses zero line, the **Zero Cross Detector** generates a pulse, and permits the TRIAC to be triggered, after $32 * T_{TB}$.

■ ABSOLUTE MAXIMUM RATINGS

PARAMETER	SYMBOL	RATINGS	UNIT
Power Supply V_{DD} with Respect to V_{SS}	$V_{DD} - V_{SS}$	5.6	V
Voltage on any Pin		-0.3 ~ 5.6	V
Operating Temperature	T_{OPR}	0 ~ 70	
Storage Temperature	T_{STG}	-65 ~ 150	

Note: Absolute maximum ratings are those values beyond which the device could be permanently damaged.

Absolute maximum ratings are stress ratings only and functional device operation is not implied.

■ ELECTRICAL CHARACTERISTICS

PARAMETER	SYMBOL	TEST CONDITONS	MIN	TYP	MAX	UNIT
Power Supply Voltage	V_{DD}			5.0±10%		V
Keep Current	I_{DD}	$V_{DD} = 5V$			1	mA
Reference Voltage	V_{REF}			3.1±0.3V		V
Reference Voltage Output Current	I_{REF}		200			μA
Gain of OP Amp			60			dB
TRIAC Sink Current	$I_{SINK(TRIAC)}$				15	mA
TRIAC Source Current	$I_{SOURCE(TRIAC)}$		50			μA
RELAY Source Current	$I_{SOURCE(RELAY)}$				5	mA
RELAY Sink Current	$I_{SINK(RELAY)}$				5	mA

■ TYPICAL APPLICATION CIRCUIT

1. TRIAC CONTROL

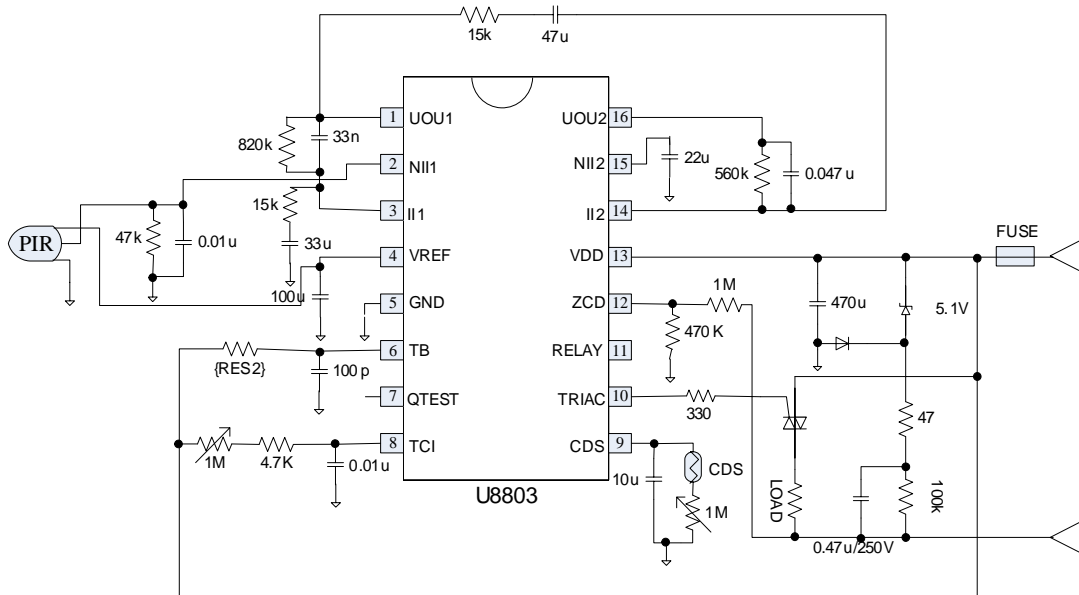

2. RELAY CONTROL

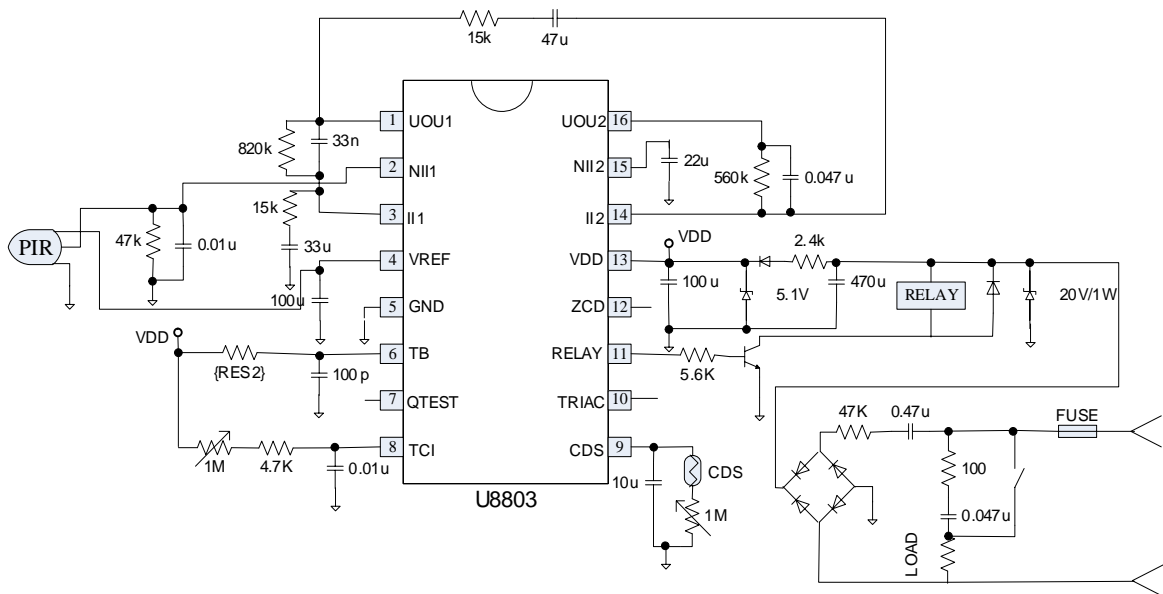

UTC assumes no responsibility for equipment failures that result from using products at values that exceed, even momentarily, rated values (such as maximum ratings, operating condition ranges, or other parameters) listed in products specifications of any and all UTC products described or contained herein. UTC products are not designed for use in life support appliances, devices or systems where malfunction of these products can be reasonably expected to result in personal injury. Reproduction in whole or in part is prohibited without the prior written consent of the copyright owner. The information presented in this document does not form part of any quotation or contract, is believed to be accurate and reliable and may be changed without notice.