



## Description

The MK3234 is the smallest size, lowest power system clock synthesizer available. It is the ideal way to generate clocks for portable computers and other devices where low power is required. Using analog Phase-Locked Loop (PLL) techniques, the device operates from a single 32.768 kHz crystal to produce the 32.768kHz, CPU, and ISA bus (system) output clocks.

The device has an individual power down pin for the CPU clock, and a power down pin for the entire device.

The MK3234 can save board space and cost even if it only replaces the 32kHz oscillator circuitry and one additional surface mount crystal or oscillator. The extremely low  $I_{DD}$ , the ease of surface mounting, the upgradeability of CPU frequencies, and the power down capability are added benefits in using the part.

## Features

- Input crystal frequency of 32.768 kHz
- Lowest power solution available
- Lowest profile clock solution where height is critical
- Output clock frequencies up to 50 MHz
- Three output clocks
- 3.3V or 5.0V operation
- Duty cycle of 45/55
- Eight selectable CPU frequencies
- CPU clock power down
- Separate battery supply pin for 32 kHz runs to 2V
- $I_{DD}$  less than 4 $\mu$ A when 32 kHz running
- Packaged in 16 pin narrow (0.150") SOIC



## Block Diagram

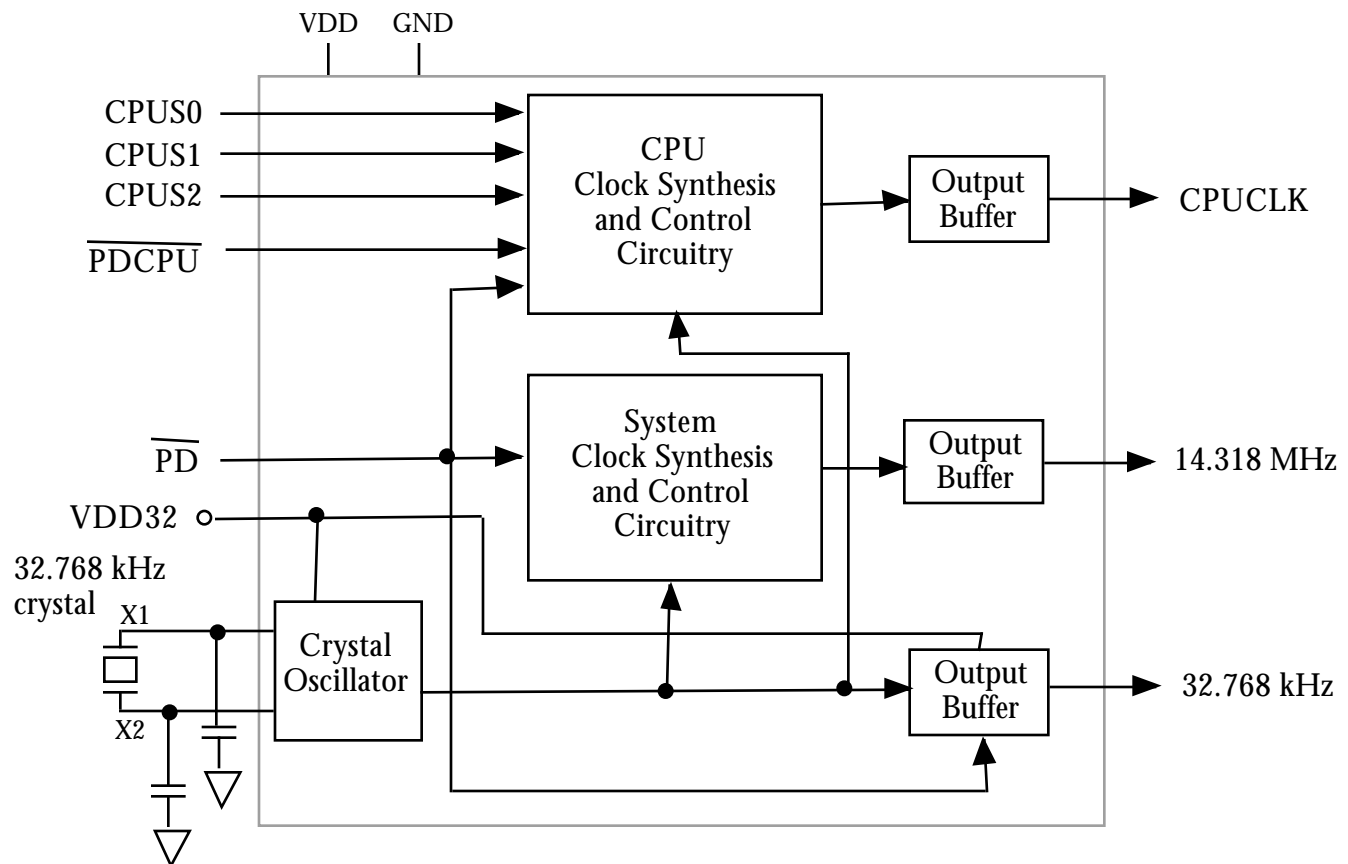



## Pin Assignment

CPUS2	1	16	CPUS1
X2	2	15	CPUS0
X1	3	14	CPUCLK
VDD32	4	13	VDD
VDD	5	12	GND
GND	6	11	14.3M
32K	7	10	$\overline{\text{PD}}$
GND	8	9	$\overline{\text{PDCPU}}$

## CPU Clock Decoding

CPUS2	CPUS1	CPUS0	CPUCLK (MHz)
0	0	0	8.00
0	0	1	13.00
0	1	0	16.00
0	1	1	20.00
1	0	0	40.00
1	0	1	25.00
1	1	0	50.00
1	1	1	33.33

Frequency transitions will occur smoothly.

## Pin Descriptions

Number	Name	Type	Description
1	CPUS2	I	Select 2 for CPUCLK frequencies. See Table above.
2	X2	O	Crystal connection. Connect to 32.768 kHz crystal.
3	X1	I	Crystal connection. Connect to 32.768 kHz crystal.
4	VDD32	P	Separate power supply connection for 32.768kHz clock. Will operate to 2.0V.
5	VDD	P	Connect to +3.3V or +5V. Must be the same voltage as pin 13.
6	GND	P	Connect to ground.
7	32K	O	32.768 kHz square wave clock output.
8	GND	P	Connect to ground.
9	$\overline{\text{PDCPU}}$	I	Power Down CPU clock output (stops low) when low.
10	$\overline{\text{PD}}$	I	Powers Down everything but 32kHz oscillator internally. 32kHz output buffer is off.
11	14.3M	O	14.318 MHz clock output. Do not use to drive video CRT controller.
12	GND	P	Connect to ground.
13	VDD	P	Connect to +3.3V or +5V. Must be the same voltage as pin 5.
14	CPUCLK	O	CPUCLK output. See Table above.
15	CPUS0	I	Select 0 for CPUCLK frequencies. See Table above.
16	CPUS1	I	Select 1 for CPUCLK frequencies. See Table above.

Type: I = Input, O = output, P = power supply connection

**Power Down status:** Output clocks will stop in a low state when powered down

## External Components

The MK3234 requires a minimum number of external components for proper operation. Decoupling capacitors of 0.1 $\mu$ F should be connected between VDD and GND, and VDD32 and GND, as close to the MK3234 as possible. A series resistor of 10k should be used on the VDD32 supply. A series termination resistor of 33 may be used for each clock output, except the 32.768 kHz. For tuning the real time clock output, use a 32.768 kHz crystal with a load capacitance of 12.5pF, and connect a 20pF $\pm$ 5% (NPO dielectric) capacitor between each crystal pin and ground. The 32.768 kHz crystal must be connected as close to the chip as possible. The 14.3 MHz output is not suitable for driving CRT displays. A separate 14.318 MHz crystal should be used at the input to the graphics controller chip. Consult MicroClock for a recommended external circuit schematic.



## Electrical Specifications

Parameter	Conditions	Minimum	Typical	Maximum	Units
<b>ABSOLUTE MAXIMUM RATINGS (note 1)</b>					
Supply Voltage, VDD	Referenced to GND			7	V
Inputs and Clock Outputs	Referenced to GND	-0.5		VDD+0.5	V
Ambient Operating Temperature		0		70	°C
Soldering Temperature	Max of 30 seconds			260	°C
Storage Temperature		-65		150	°C
<b>DC CHARACTERISTICS (at 5.0V unless otherwise noted)</b>					
Operating Voltage, VDD		3.0		5.5	V
Operating Voltage, VDD32		2.0		5.5	V
Input High Voltage, VIH	VDD=5V	2.0			V
Input Low Voltage, VIL	VDD=5V			0.8	V
Output High Voltage, VOH	VDD=5V, IOH=-25mA	2.4			V
Output Low Voltage, VOL	VDD=5V, IOL=25mA			0.4	V
Input High Voltage, VIH	VDD=3.3V	1.9			V
Input Low Voltage, VIL	VDD=3.3V			0.4	V
Output High Voltage, VOH	VDD=3.3V, IOH=-8mA	2.4			V
Output Low Voltage, VOL	VDD=3.3V, IOL=8mA			0.4	V
IDD Operating Supply Current, 5V	No Load, 50MHz		15		mA
IDD32 with only 32 kHz running, 5V	No Load		3.5		µA
IDD Operating Supply Current, 3.3V	No Load, 50MHz		9		mA
IDD32 with only 32 kHz output running, 3.3V	No Load		2.5		µA
IDD32, only 32 kHz osc. running, 3.3V, note 2	32kHz output off. PD=0		1		µA
Short Circuit Current, 5V	32 kHz output		±30		mA
Short Circuit Current, 5V	CPU output		±100		mA
Input Capacitance			7		pF
<b>AC CHARACTERISTICS (at 5.0V unless otherwise noted)</b>					
Input Frequency			32.768		kHz
Output Clock Rise and Fall Time, 0.2 to 0.8VDD				2	ns
Output Clock Duty Cycle, all MHz clocks	At VDD/2	45	49 to 51	55	%
32.768 kHz Clock Duty Cycle	At VDD32/2		57		%
Absolute Clock Period Jitter, CPU clock	20 to 50 MHz	-500		500	ps
Power up time, CPU off to 50 MHz, 32k running	VDD=3.3 or 5V		9		ms
Transition time, 8 MHz to 50 MHz	VDD=3.3 or 5V		4		ms
Transition time, 50 MHz to 8 MHz	VDD=3.3 or 5V		2.5		ms
Power on time, VDD32=0V to all clocks stable	32.768kHz crystal with ESR 25k		500	1000	ms
Power on time, all power down pins taken high	32.768kHz oscillator running		15		ms

Note 1: Stresses beyond those listed under Absolute Maximum Ratings could cause permanent damage to the device. Prolonged exposure to levels above the operating limits but below the Absolute Maximums may affect device reliability.

Note 2: When PD=0 (low) and VDD32 is greater than 2.0V, then the 32kHz oscillator will continue to run on the chip, but the output is turned off. This allows for a quick power-up (<20ms), while the chip is only consuming approximately 1µA.



## Package Outline and Package Dimensions

### 16 pin SOIC narrow

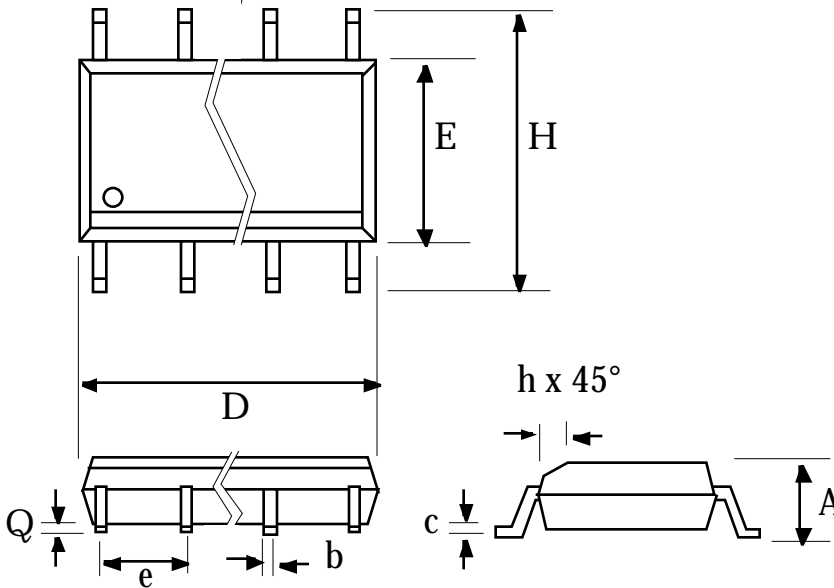

Symbol	Inches		Millimeters	
	Min	Max	Min	Max
A	0.055	0.068	1.397	1.7272
b	0.013	0.019	0.330	0.483
c	0.007	0.010	0.191	0.254
D	0.385	0.400	9.779	10.160
E	0.150	0.160	3.810	4.064
H	0.225	0.245	5.715	6.223
e	.050 BSC		1.27 BSC	
h		0.016		0.406
Q	0.004	0.01	0.102	0.254

## Ordering Information

Part/Order Number	Marking	Package	Temperature
MK3234-01S	MK3234-01S	16 pin SOIC	0-70°C
MK3234-01STR	MK3234-01S	Add Tape & Reel	0-70°C

While the information presented herein has been checked for both accuracy and reliability, MicroClock Incorporated assumes no responsibility for either its use or for the infringement of any patents or other rights of third parties, which would result from its use. No other circuits, patents, or licenses are implied. This product is intended for use in normal commercial applications. Any other applications such as those requiring extended temperature range, high reliability, or other extraordinary environmental requirements are not recommended without additional processing by MicroClock. MicroClock reserves the right to change any circuitry or specifications without notice. MicroClock does not authorize or warrant any MicroClock product for use in life support devices or critical medical instruments.