

Features

- Differential to single ended conversion
- No transformers required
- Minimum installation space
- Off-Hook detection and LED indicator drive
- Relay drive output
- Battery and ringing feed to line
- Logic interface: $\overline{\text{MUTE}}$, $\overline{\text{OFHK}}$, RC
- Mute of incoming audio
- Dial pulse detection
- Voltage surge protection

Applications

Line Interface for:

- PABX
- Intercoms
- Key Systems

Ordering Information

MH88500 20 Pin SIL Package

0°C to 70°C

Description

The Mitel MH88500 Subscriber Line Interface Circuit provides a complete interface between the telephone line and a speech switch requiring only single bidirectional switch per crosspoint. The functions provided by the MH88500 include bidirectional differential to single ended conversion in the speech path, line battery feed, ringing feed and loop and dial pulse detection. The device is fabricated as a thick film hybrid in a 20-pin 'single-in-line' package allowing optimum circuit board packing density.

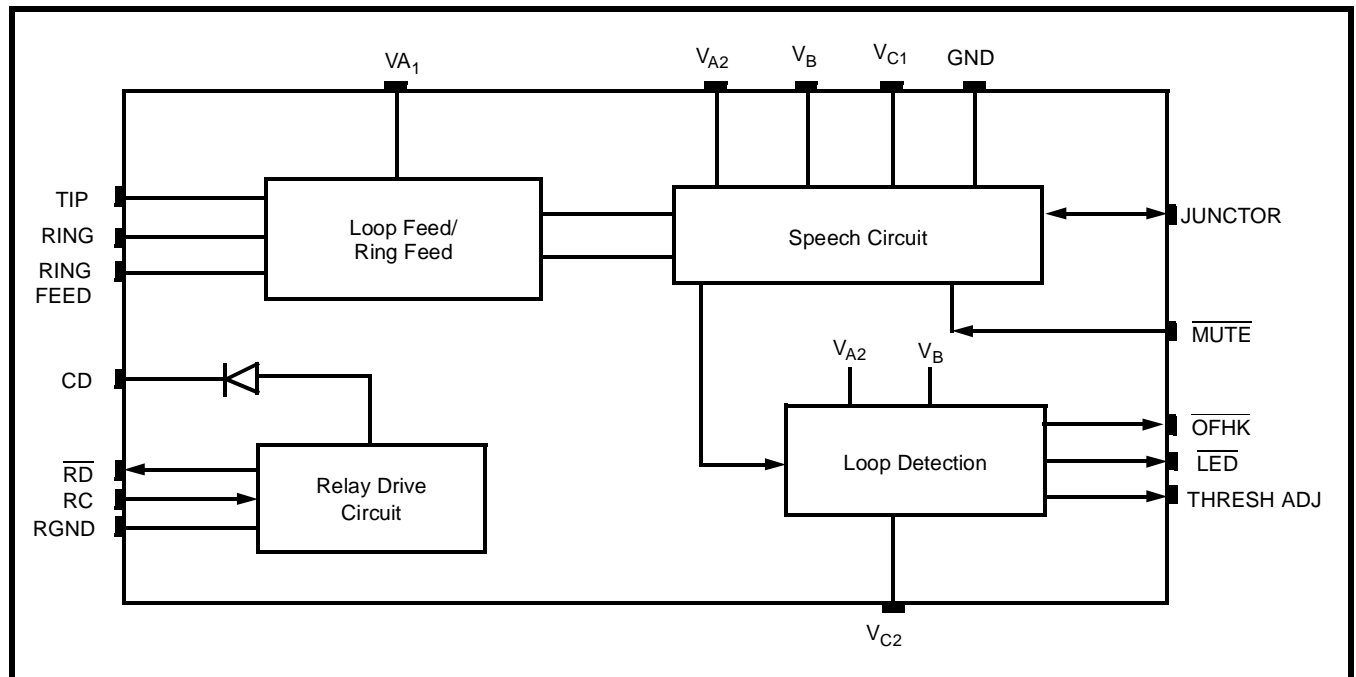

Figure 1 - Functional Block Diagram

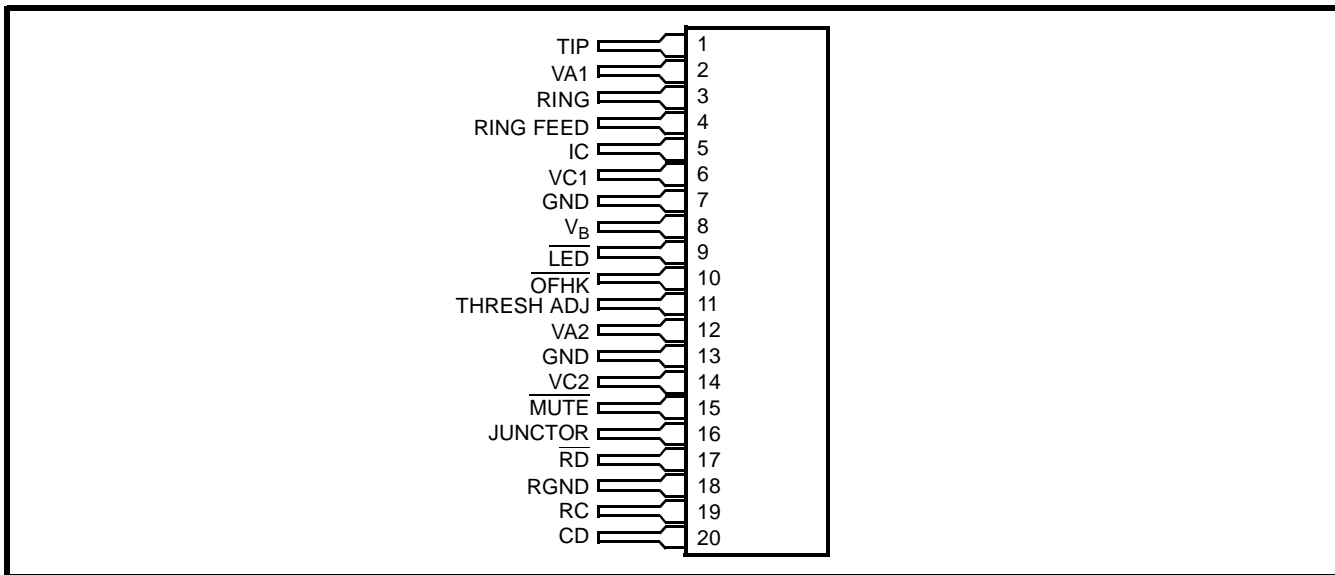

Figure 2 - Pin Connections

Pin Description

Pin #	Name	Description
1	TIP	Tip Lead. Connects to the “Tip” lead (A-wire) of the telephone line.
2	V _{A1}	Positive Line Feed Supply Voltage. Normally connected to V _{A2} .
3	RING	Ring Lead. Connects to the “Ring” lead (B-wire) of the telephone line.
4	RING FEED	Negative Line Feed Voltage and Ringing Input. Normally connected to Ring Relay.
5	IC	Internal Connection. Leave open circuit. Use for testing only.
6	V _{C1}	Sense Input. Normally connected to negative line feed voltage supply.
7	GND	Analog ground (0V). Internally connected to pin 13.
8	V _B	Negative Analog Supply Voltage.
9	LED	LED Drive Output. Drives an LED directly. Off-Hook condition, logic low.
10	OFHK	Logic Low Output. Indicates closed loop condition (Off-Hook and dial pulsing).
11	THRESH ADJ	Allows adjustment of OFHK detection threshold.
12	V _{A2}	Positive Power Supply Voltage. Normally connected to V _{A1} .
13	GND	Analog Ground (0V). Internally connected to pin 7.
14	V _{C2}	Loop Detector Voltage Supply. Connected to negative line feed voltages supply.
15	MUTE	Input mutes the incoming audio. Active low.
16	JUNCTOR	Receive/transmit audio speech path. (referenced to 0V GND)
17	RD	Relay Drive Output. Open collector sinks current when RC high. Diode clamp protected.
18	RGND	Ground for Relay Drive Circuit.
19	RC	Ring Control Input. Active high.
20	CD	Clamping Diode. Normally connected to relay positive voltage.

Functional Description

Speech Circuit

The speech circuit converts the bidirectional TIP and RING line pair to a bidirectional single ended junctor line. Figure 3 illustrates a typical connection between two SLIC's through two crosspoint switches. This configuration gives optimum transhybrid loss as seen from Figure 4 given that the output impedance of the Junctor line is 604Ω.

The MUTE input mutes signals coming from TIP and RING to the junctor line while allowing the signal from the junctor to the tip-ring pair to be transmitted.

Loop Detection

The loop detection circuit determines whether a low enough impedances is across TIP and RING to be recognized as an off-hook condition.

(Threshold impedance = 5.4kΩ with no adjustment)
 This threshold level can be adjusted by the use of external resistors as shown in Figure 6. OFHK has low output drive capability so it may drive CMOS operating with different power supplies.

Line Feed/Ring Feed Circuit

The line feed circuit provides loop current and the ability to apply ringing onto TIP and RING. The impedance from Ring Feed to GND is 600Ω which gives the loop current as:

$$I_L = \frac{\text{Voltage at RING FEED pin}}{\text{Telephone Impedance} + 600} \quad \text{Amps}$$

The positive supply for the line feed circuit is V_{A1} through the loop current is determined from RING FEED and GND.

Relay Drive Circuit

The relay drive circuit switches ringing onto RING FEED (Fig.7). The diode is present to suppress voltage transients during relay switches caused by the inductive coils of the relay. Ringing voltage includes AC ringing (90V typically) an dDC line feed voltage (-24V typically).

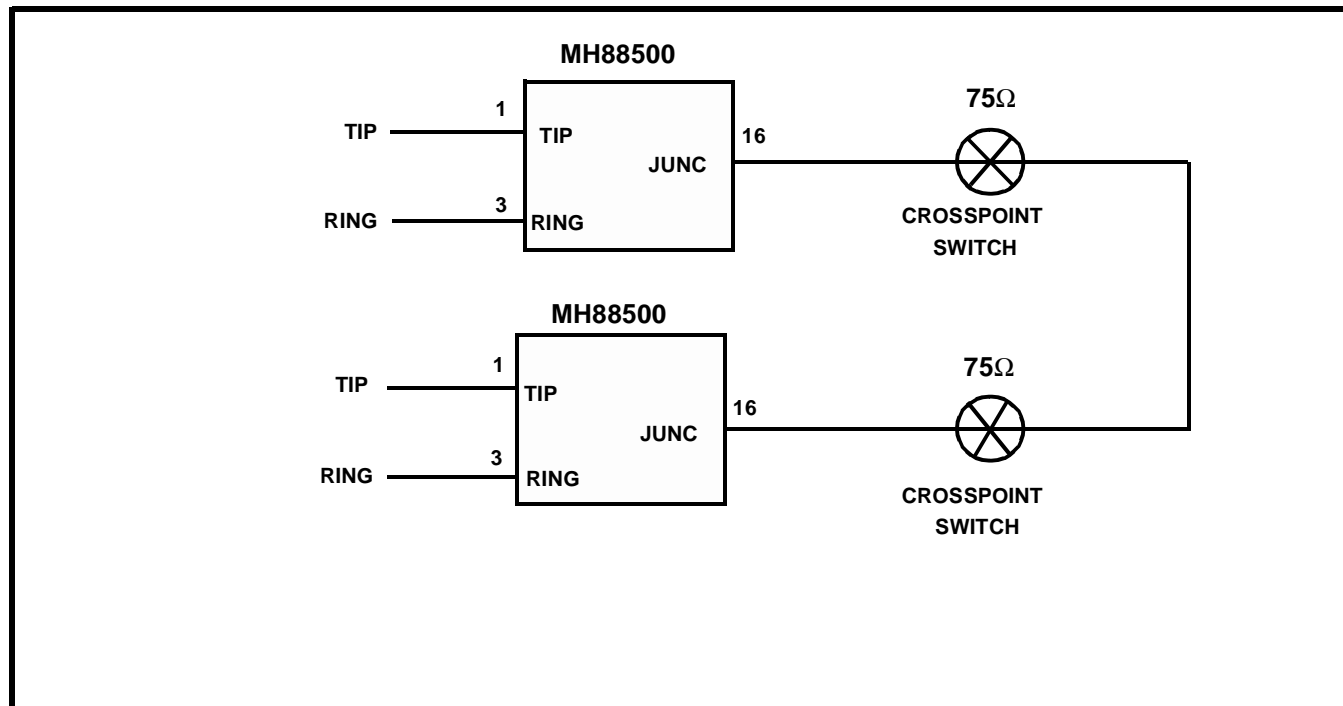

Figure 3 - SLIC Crosspoint Switch Connection

Absolute Maximum Ratings†

	Parameter	Symbol	Min	Max	Units
1	Voltage Supplies - V_{Ref} to GND	V_{A1}, V_{A2}			V
		V_B	-18	+18	V
		V_{C1}, V_{C2}	-35		V
2	Clamp Diode Breakdown Voltage- V_{Ref} to RGND	V_{CD}		+15	V
3	Operating Temperature	T_{AMB}	0	+70	°C
4	Storage Temperature	T_{STG}	-40	+100	°C
5	Power Dissipation	P_D		1.2	Watt

† Exceeding these values may cause permanent damage. Functional operation under these conditions is not implied.

AC Electrical Characteristics†

Voltages are with respect to ground (V_{SS}), $T_A = 25^\circ\text{C}$, unless otherwise stated.
Test conditions unless noted, $V_{A1}=V_{A2}=+7\text{V}$, $V_B=8\text{V}$, $V_{C2}=-24\text{V}(\pm 5\%)$.

	Characteristics	Sym	Min	Typ‡	Max	Units	Test Conditions	
1	Junctor to differential output (tip-ring) gain.	A_{JL}	2.18	2.25 7	2.32	V/V dB	1kHz, 400mV _{RMS} source on pin 16. Note 2	
2	Differential Input (tip-ring) to junctor gain	A_{LJ}	0.303	0.321	0.321	V/V dB	1kHz, 1V _{RMS} Source on pins 1&3. Note 1,2	
3	On/Off Hook Detection Threshold	Loop Resist	R_{Thresh}	4.0	5.4	6.0	k Ω	Note 1. Note 1
		Loop Current	I_{Thresh}	3.6	4.0	5.3	mA	
4	Trans Hybrid Loss			55		dB	Notes 1,2. See Figure 2	
5	Passband Linearity			± 1		dB	Notes 1,2	
6	Power Supply Rejection Ratio (VC to Junctor)	PSRR		40		dB	Notes 1,2	
7	Common Mode Rejection Ratio (Tip and Ring to Junctor)	CMRR		40		dB	Notes 1,2	
8	Low Frequency Cutoff (3dB)	Junctor to Line	F_{LLJ}	53		Hz	Notes 1,2	
		Line to Junctor	F_{LJL}	20		Hz	Notes 1,2	
9	High Frequency Cutoff (3dB)	Line to Junctor	F_{HLJ}	800		kHz	Notes 1,2	
		Junctor to Line	F_{HJL}	500		kHz	Notes 1,2	
10	Longitudinal Balance			65		dB	Note 1	
11	Tip (or Ring) to ground AC input impedance	Z_I		300		Ω		
12	Junctor output impedance	Z_{OJ}		604		Ω		

† Exceeding these values may cause permanent damage. Functional operation under these conditions is not implied.

‡ Typical figures are at 25°C with nominal $\pm 5\text{V}$ supplies and are for design aid only: not guaranteed and not subject to production testing.

Note 1: 754 Ω connected between JUNCTOR (pin 16) and OV.

Note 2: 604 Ω connected between TIP (pin 1) and RING (pin 3).

DC Electrical Characteristics

		Characteristics	Sym	Min	Typ [‡]	Max	Units	Test Conditions
1	SUPPLY	Operating Supply Voltages	V _{A1} , V _{A2} V _B V _{C1} , V _{A2}	-13 -30	-24	+13 -20	V V V	
2		Operating Supply Currents	I _{A1} I _{A2} I _B I _{C1} I _{C2}		7 8 6 .2 .1		mA mA mA mA mA	
3	INPUTS	High Level Input Voltage $\overline{\text{MUTE}}$ RC	V _{IH} V _{IH}	4.2 3			V V	
4		Low Level Input Voltage $\overline{\text{MUTE}}$ RC	V _{IL} V _{IL}	.8 1			V	
5		High Level Input Current $\overline{\text{MUTE}}$ RC	I _{IH} I _{IH}	-28 700			μA μA	
6		Low Level input Current $\overline{\text{MUTE}}$ RC	I _{IL} I _{IL}	100 1			μA μA	
7	OUTPUTS	Sink Current $\overline{\text{LED}}$ RD	I _{LED} I _{RD}	2 65	6 100		mA mA	V _{OFHK} , -6V CD=RC=5V, RGD=0V V _{RRD} <1.5V
8		Diode Clamp Current	I _{RLY}	65	100		mA	RC=RGND=0V, CD=5V V _{RRD} <1.5V
9		High Level Output Voltage	V _{OH}	6			V	$\overline{\text{LED}}$ Unconnected
10		Low Level Output Voltage OFHK	V _{OL}	-6.5			V	$\overline{\text{LED}}$ Unconnected
11		High Level Output Current	I _{OH}	10			μA	
12		Low Level Output Current	I _{OL}	10			μA	

‡ Typical figures are at 25°C with nominal ± 5V supplies and are for design aid only: not guaranteed and not subject to production testing.

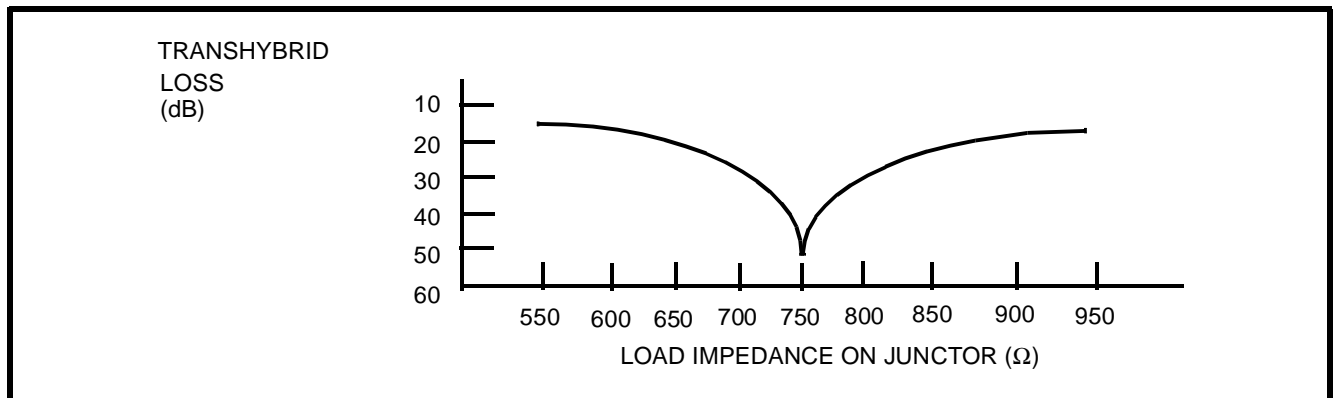

Figure 4 - Return Loss VS Junctor Load Impedance

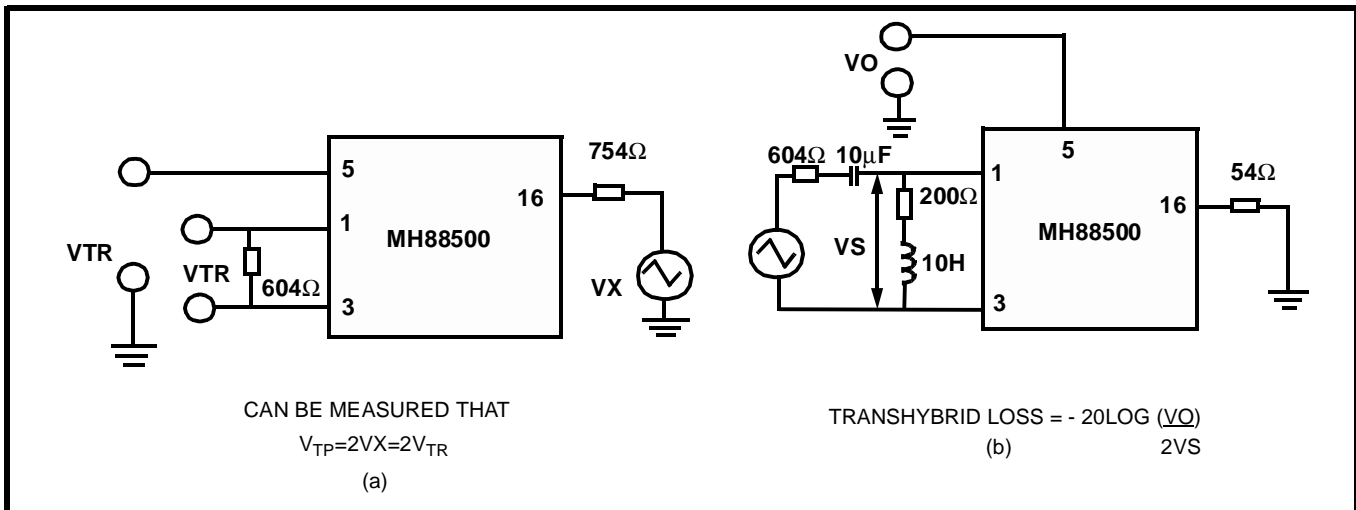

Figure 5 - Transhybrid Loss Test Circuit

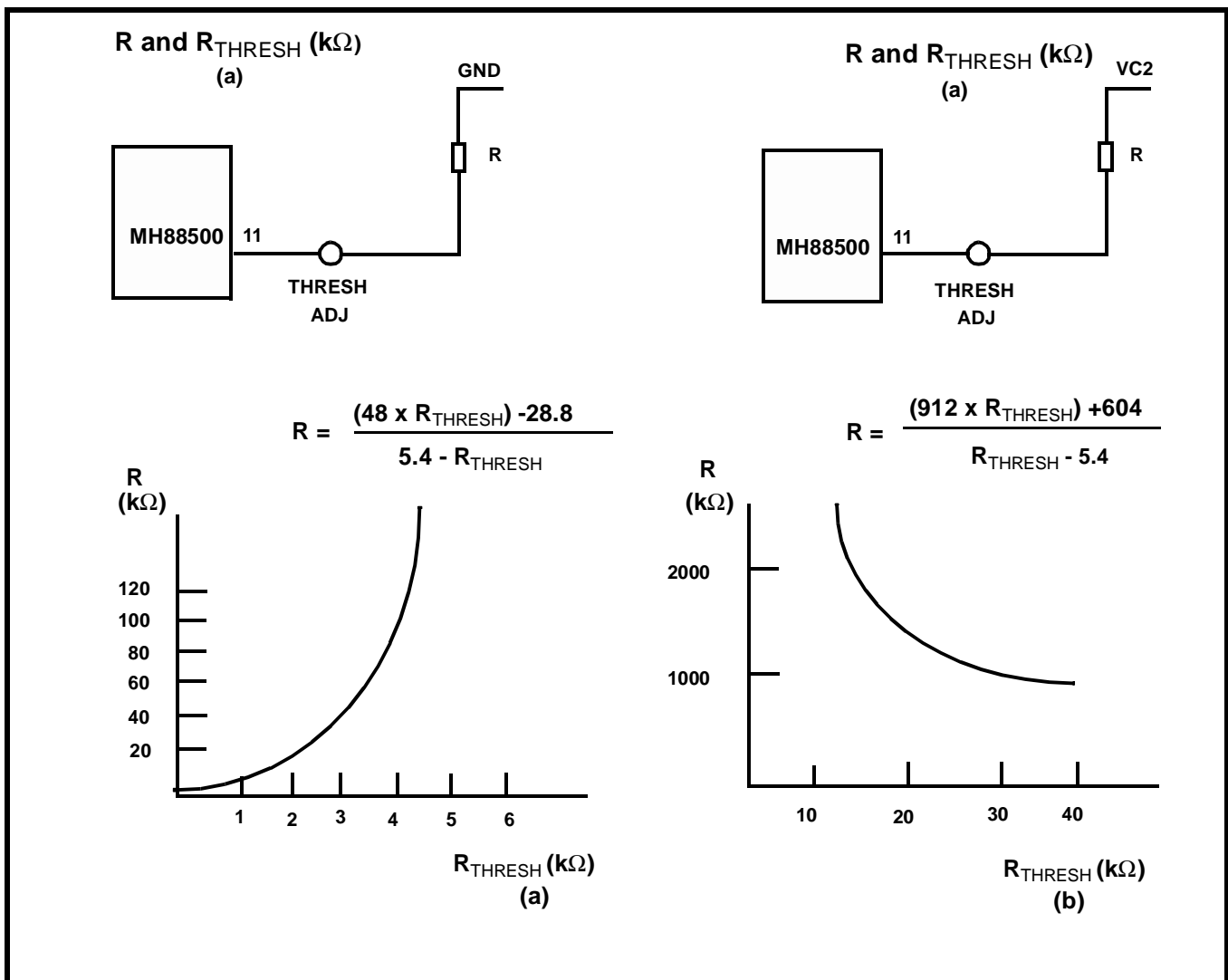

Figure 6 - Off-Hook Threshold Adjust

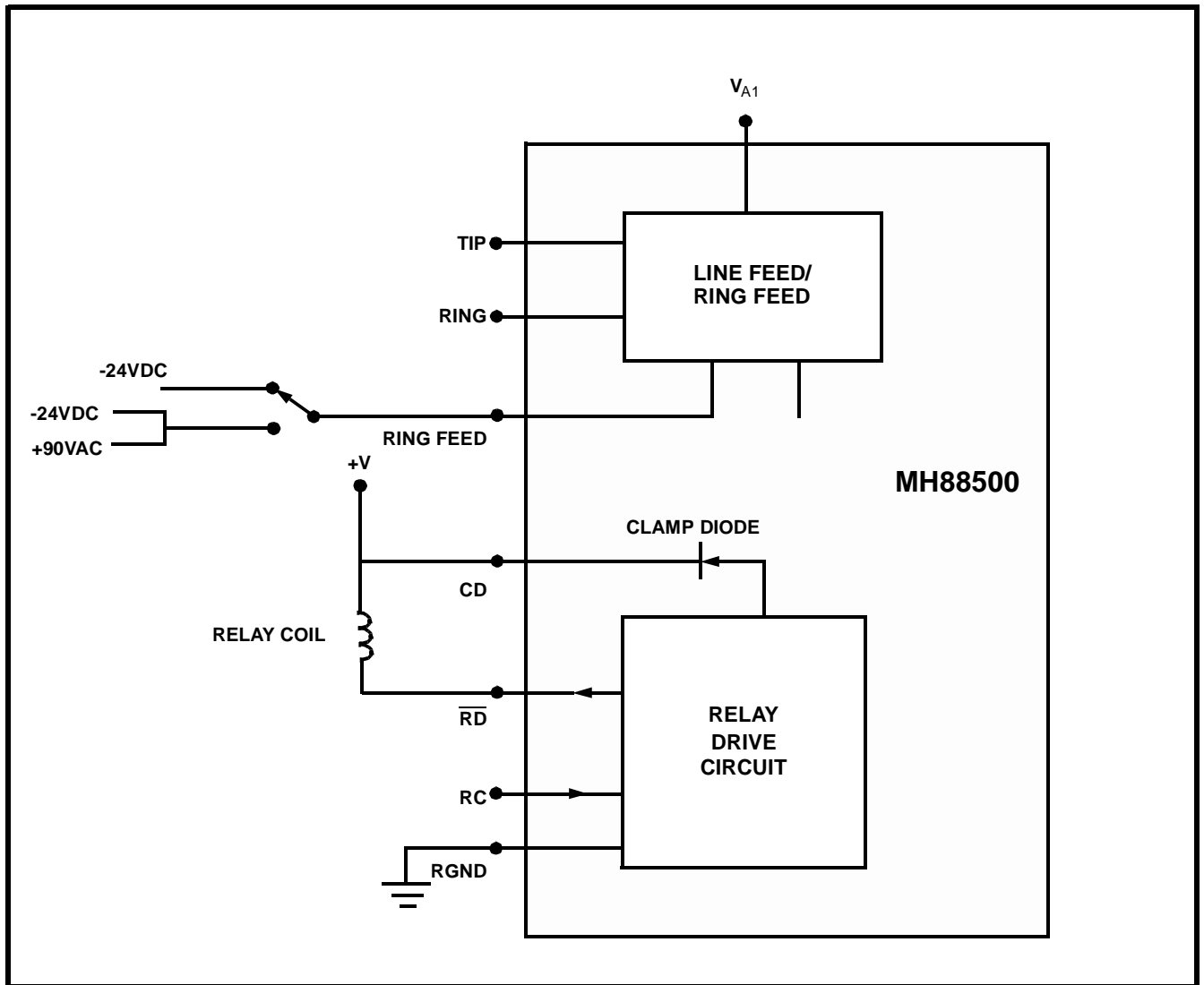

Figure 7 - Relay Drive Circuit

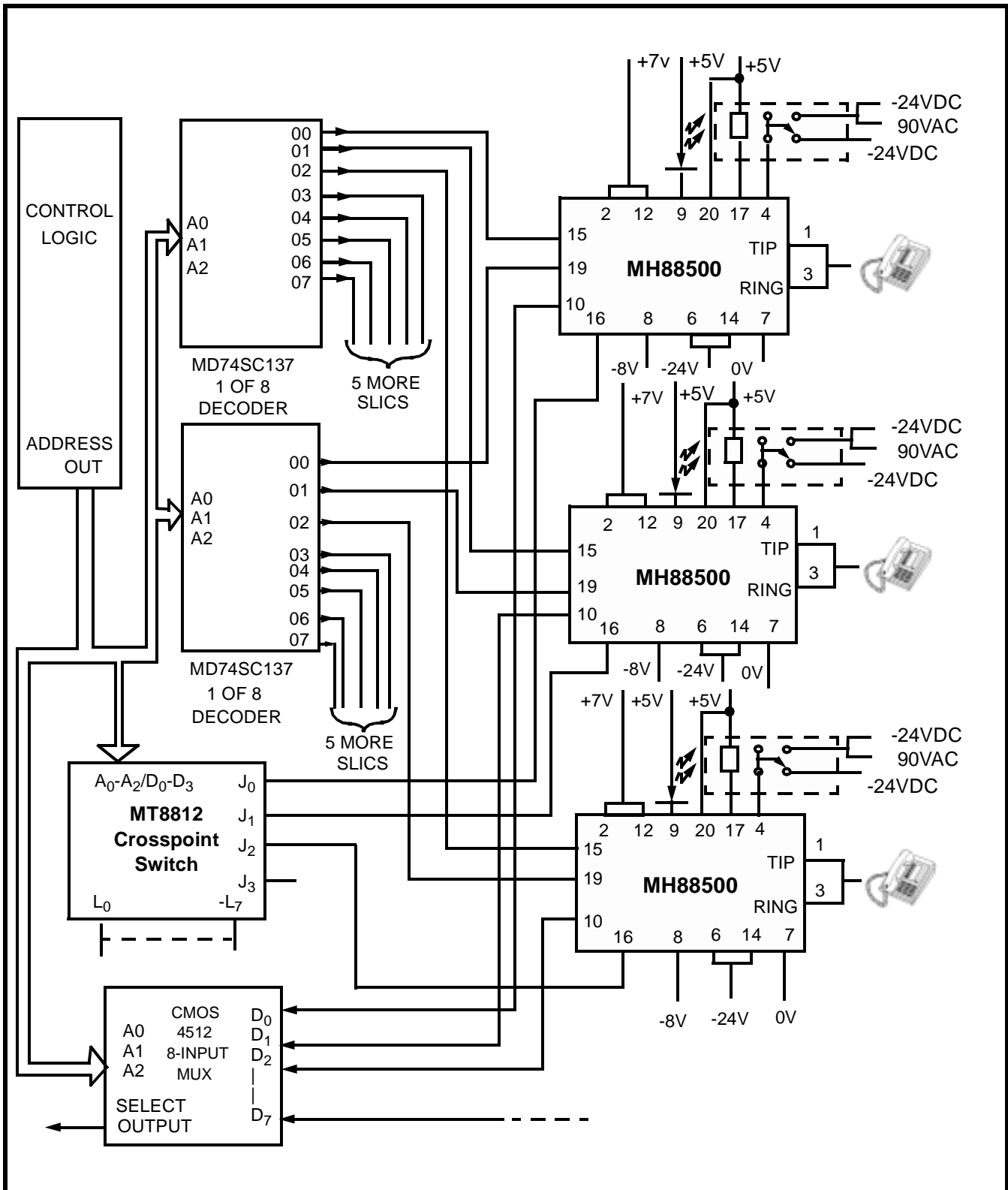

Figure 8 - PABX Typical Application

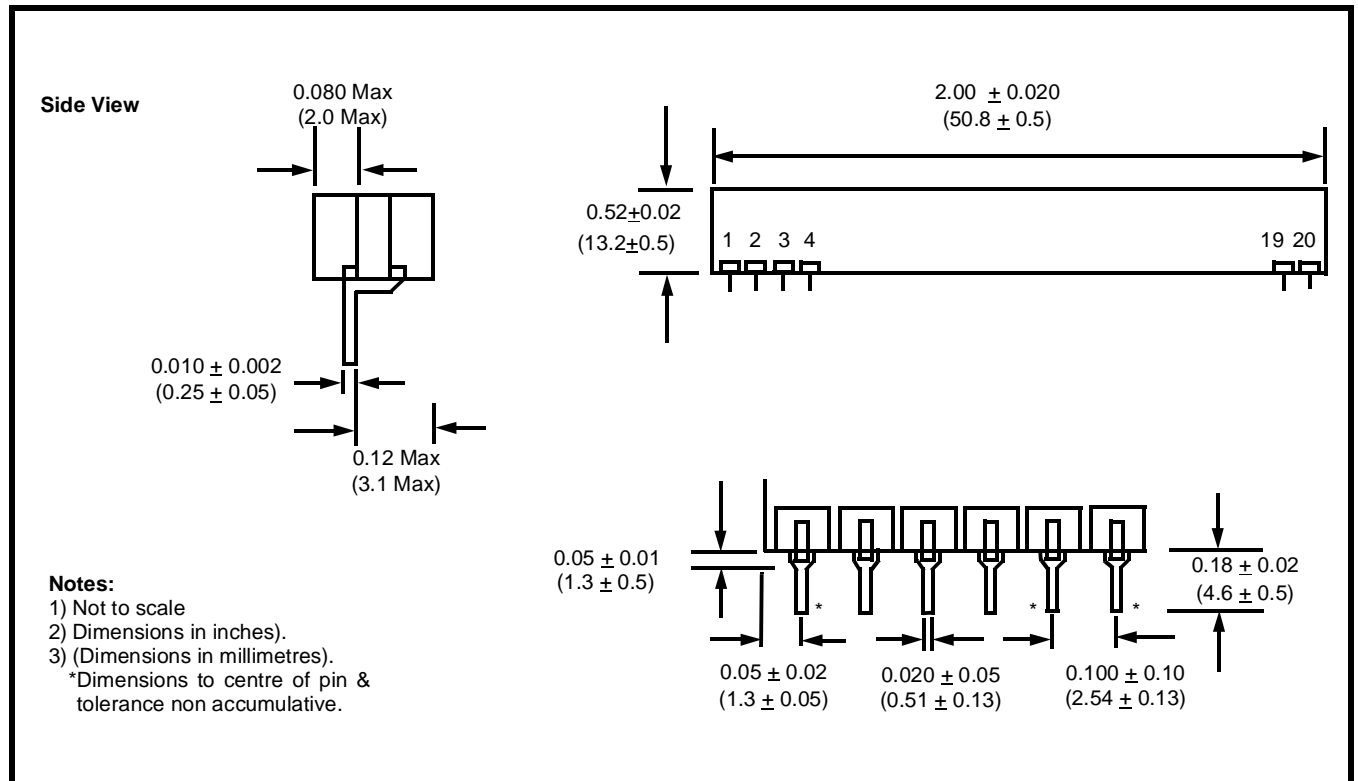

Figure 9 -Mechanical Data

Notes: