

## 1. General Description

This EPROM-Based 8-bit micro-controller uses a fully static CMOS design technology combines higher speed and smaller size with the low power and high noise immunity of CMOS.

On chip memory system includes 2.0 K bytes of ROM, and 80 bytes of static RAM.

## 2. Features

The followings are some of the features on the hardware and software :

- ◆ Fully CMOS static design
- ◆ 8-bit data bus
- ◆ On chip ROM size : 2 K words
- ◆ Internal RAM size : 80 bytes  
(72 general purpose, 8 special registers)
- ◆ 36 single word instructions
- ◆ 14-bit instructions
- ◆ 2-level stacks
- ◆ Operating voltage : 2.3 V ~ 6.0 V
- ◆ Operating frequency : 0 ~ 20 MHz
- ◆ The most fast execution time is 200 ns under 20 MHz in all single cycle instructions except the branch instruction.
- ◆ Addressing modes include direct, indirect and relative addressing

modes

- ◆ Power-on Reset
- ◆ Power Edge-detector Reset
- ◆ Sleep mode for power saving
- ◆ 4 oscillator start-up time :  
150  $\mu$ s, 20 ms, 40 ms, 80 ms
- ◆ 8-bit real time clock/counter(RTCC) with 8-bit programmable prescaler
- ◆ 4 types of oscillator can be selected by code options :
  - RC - Low cost RC oscillator
  - LFXT - Low frequency crystal oscillator
  - XTAL - Standard crystal oscillator
  - HFXT - High frequency crystal oscillator
- ◆ On-chip RC oscillator based Watchdog Timer(WDT) can be operated freely
- ◆ 20 I/O pins with their own independent direction control

## 3. Applications

The application areas of this MDT10P20 range from appliance motor control and high speed automotive to low power remote transmitters/receivers, pointing devices, and telecommunications processors, such as Remote controller, small instruments, chargers, toy, automobile and PC peripheral ... etc.

**4. Pin Assignment**

<b>DIP / SOP / SKINNY</b>				<b>SSOP</b>			
RTCC	1	28	/MCLR	VSS	1	28	/MCLR
V <sub>dd</sub>	2	27	OSC1	RTCC	2	27	OSC1
N/C	3	26	OSC2	VDD	3	26	OSC2
V <sub>ss</sub>	4	25	PC7	VDD	4	25	PC7
N/C	5	24	PC6	PA0	5	24	PC6
PA0	6	23	PC5	PA1	6	23	PC5
PA1	7	22	PC4	PA2	7	22	PC4
PA2	8	21	PC3	PA3	8	21	PC3
PA3	9	20	PC2	PB0	9	20	PC2
PB0	10	19	PC1	PB1	10	19	PC1
PB1	11	18	PC0	PB2	11	18	PC0
PB2	12	17	PB7	PB3	12	17	PB7
PB3	13	16	PB6	PB4	13	16	PB6
PB4	14	15	PB5	VSS	14	15	PB5

**5. Pin Function Description**

Pin Name	I/O	Function Description
PA0~PA3	I/O	Port A, TTL input level
PB0~PB7	I/O	Port B, TTL input level
PC0~PC7	I/O	Port C, TTL input level
RTCC	I	Real Time Clock/Counter, Schmitt Trigger input levels
/MCLR	I	Master Clear, Schmitt Trigger input levels
OSC1	I	Oscillator Input
OSC2	O	Oscillator Output
V <sub>dd</sub>		Power supply
V <sub>ss</sub>		Ground

6. Memory Map

(A) Register Map

Address	Description
00	Indirect Addressing Register
01	RTCC
02	PC
03	STATUS
04	MSR
05	Port A
06	Port B
07	Port C
08~0F	Internal RAM, General Purpose Register
10~1F	Internal Memory Select Register
30~3F	Internal Memory Select Register
50~5F	Internal Memory Select Register
70~7F	Internal Memory Select Register

(1) IAR ( Indirect Address Register) : R0

(2) RTCC (Real Time Counter/Counter Register) : R1

(3) PC (Program Counter) : R2

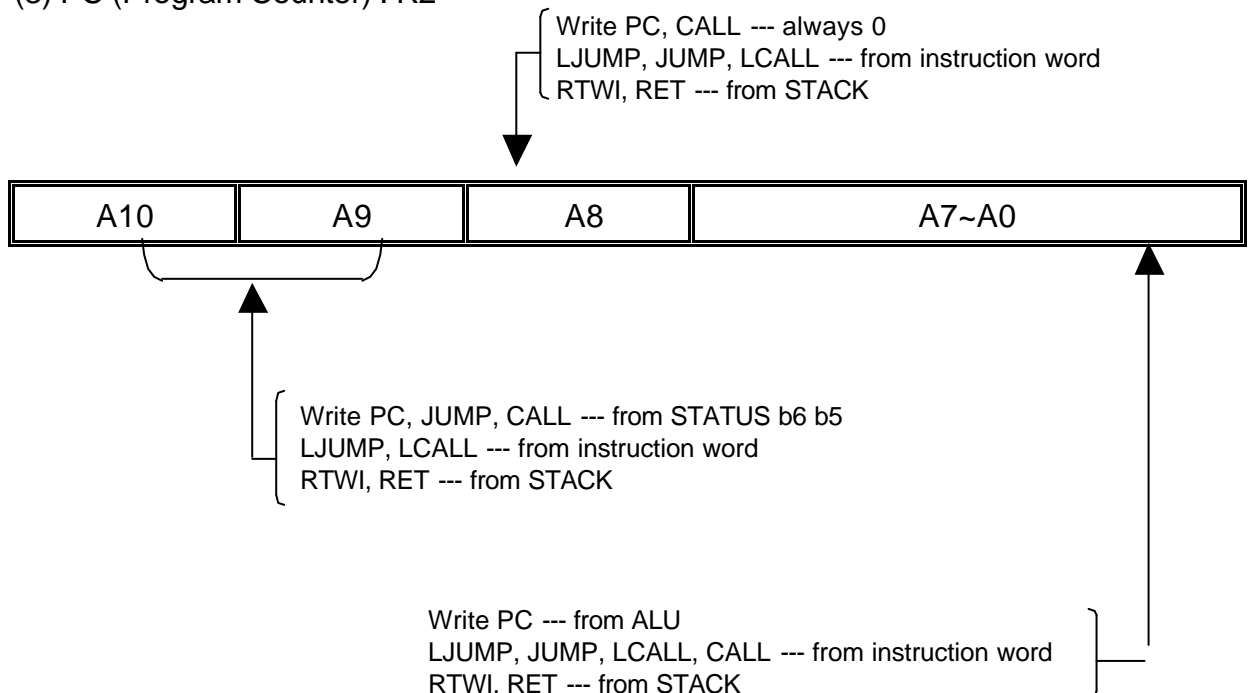

(4) STATUS (Status register) : R3

Bit	Symbol	Function
0	C	Carry bit
1	HC	Half Carry bit
2	Z	Zero bit
3	PF	Power loss Flag bit
4	TF	Time overflow Flag bit
6—5	page	Page select bit : 00 : 000H --- 1FFH 01 : 200H --- 3FFH 10 : 400H --- 5FFH 11 : 600H --- 7FFH
7	—	General purpose bit

(5) MSR (Memory Select Register) : R4

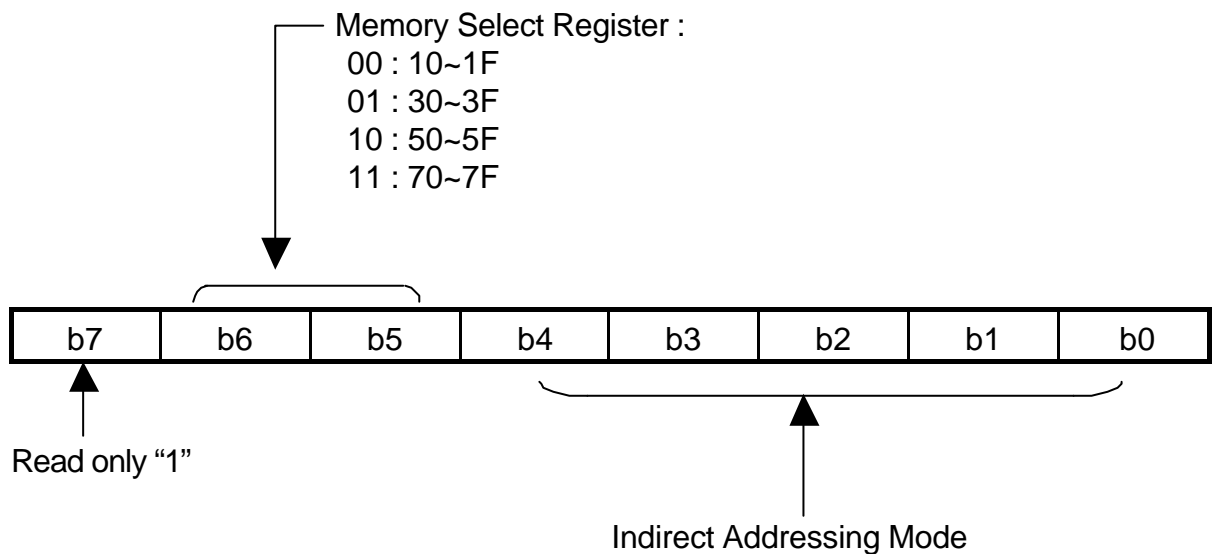

(6) PORT A : R5

PA3~PA0, I/O Register

(7) PORT B : R6

PB7~PB0, I/O Register

(8) PORT C : R7

PC7~PC0, I/O Register

(9) TMR (Time Mode Register)

Bit	Symbol	Function		
2—0	PS2—0	Prescaler Value	RTCC rate	WDT rate
		0 0 0	1 : 2	1 : 1
		0 0 1	1 : 4	1 : 2
		0 1 0	1 : 8	1 : 4
		0 1 1	1 : 16	1 : 8
		1 0 0	1 : 32	1 : 16
		1 0 1	1 : 64	1 : 32
		1 1 0	1 : 128	1 : 64
		1 1 1	1 : 256	1 : 128
3	PSC	Prescaler assignment bit : 0 — RTCC 1 — Watchdog Timer		
4	TCE	RTCC signal Edge : 0 — Increment on low-to-high transition on RTCC pin 1 — Increment on high-to-low transition on RTCC pin		
5	TCS	RTCC signal set : 0 — Internal instruction cycle clock 1 — Transition on RTCC pin		

(10) CPIO A, CPIO B, CPIO C (Control Port I/O Mode Register)

The CPIO register is “write -only”

= “0”, I/O pin in output mode;

= “1”, I/O pin in input mode.

(11) EPROM Option by Writer Programming:

Oscillator Type	Oscillator Start-up Time
RC Oscillator	150 μs,20ms,40ms,80ms
HFXT Oscillator	20 ms,40ms,80ms
XTAL Oscillator	20ms,40 ms,80ms
LFXT Oscillator	40ms,80 ms

Watchdog Timer control
Watchdog timer disable all the time
Watchdog timer enable all the time

Power Edge Detect	
PED	Disable
PED	Enable

Security bit	
Security weak Disable	
Security Disable	
Security Enable	

**7. Reset Condition for all Registers**

Register	Address	Power-On Reset	/MCLR or WDT Reset
CPIO A	- -	1111 1111	1111 1111
CPIO B	- -	1111 1111	1111 1111
CPIO C	- -	1111 1111	1111 1111
TMR	- -	--11 1111	--11 1111
IAR	00h	-	-
RTCC	01h	xxxx xxxx	uuuu uuuu
PC	02h	1111 1111	1111 1111
STATUS	03h	0001 1xxx	000# #uuu
MSR	04h	100x xxxx	100u uuuu
PORT A	05h	---- xxxx	---- uuuu
PORT B	06h	xxxx xxxx	uuuu uuuu
PORT C	07h	xxxx xxxx	uuuu uuuu

Note : u = unchanged, x = unknown, - = unimplemented, read as "0"  
 # = value depends on the condition of the following table

Condition	Status: bit 4	Status: bit 3
/MCLR reset (not during SLEEP)	u	u
/MCLR reset during SLEEP	1	0
WDT reset (not during SLEEP)	0	1
WDT reset during SLEEP	0	0

8. Instruction Set

Instruction Code	Mnemonic Operands	Function	Operating	Status
010000 00000000	NOP	No operation	None	
010000 00000001	CLRWT	Clear Watchdog timer	0 WT	TF, PF
010000 00000010	SLEEP	Sleep mode	0 WT, stop OSC	TF, PF
010000 00000011	TMODE	Load W to TMODE register	W TMODE	None
010000 00000100	RET	Return	Stack PC	None
010000 00000rrr	CPIO R	Control I/O port register	W CPIO r	None
010001 1rrrrrrr	STWR R	Store W to register	W R	None
011000 trrrrrrr	LDR R, t	Load register	R t	Z
111010 iiiiii	LDWI I	Load immediate to W	I W	None
010111 trrrrrrr	SWAPR R, t	Swap halves register	[R(0~3) ↔ R(4~7)] t	None
011001 trrrrrrr	INCR R, t	Increment register	R + 1 t	Z
011010 trrrrrrr	INCRSZ R,	Increment register, skip if zero	R + 1 t	None
011011 trrrrrrr	ADDWR R, t	Add W and register	W + R t	C, HC, Z
011100 trrrrrrr	SUBWR R, t	Subtract W from register	R - W t (R+W+1 t)	C, HC, Z
011101 trrrrrrr	DECR R, t	Decrement register	R - 1 t	Z
011110 trrrrrrr	DECRSZ R, t	Decrement register, skip if zero	R - 1 t	None
010010 trrrrrrr	ANDWR R, t	AND W and register	R W t	Z
110100 iiiiii	ANDWI I	AND W and immediate	I W W	Z
010011 trrrrrrr	IORWR R, t	Inclu. OR W and register	R W t	Z
110101 iiiiii	IORWI I	Inclu. OR W and immediate	I W W	Z
010100 trrrrrrr	XORWR R, t	Exclu. OR W and register	R W t	Z
110110 iiiiii	XORWI I	Exclu. OR W and immediate	I W W	Z
011111 trrrrrrr	COMR R, t	Complement register	/R t	Z
010110 trrrrrrr	RRR R, t	Rotate right register	R(n) R(n-1), C R(7) R(0) C	C
010101 trrrrrrr	RLR R, t	Rotate left register	R(n) (n+1), C R(0) R(7) C	C
010000 1xxxxxxx	CLRW	Clear working register	0 W	Z
010001 0rrrrrrr	CLRR R	Clear register	0 R	Z
0000bb brrrrrrr	BCR R, b	Bit clear	0 R(b)	None
0010bb brrrrrrr	BSR R, b	Bit set	1 R(b)	None

This specification are subject to be changed without notice. Any latest information please preview

Instruction Code	Mnemonic Operands	Function	Operating	Status
0001bb brrrrrrr	BTSC R , b	Bit Test , skip if clear	Skip if R(b)=0	None
0011bb brrrrrrr	BTSS R , b	Bit Test , skip if set	Skip if R(b)=1	None
100nnn nnnnnnnn	LCALL n	Long CALL subroutine	n PC , PC+1 Stack	None
101nnn nnnnnnnn	LJUMP n	Long JUMP to address	n PC	None
110000 nnnnnnnn	CALL n	Call subroutine	n PC, PC+1 Stack	None
110001 iiiiii	RTWI i	Return, place immediate to W	Stack PC, i W	None
11001n nnnnnnnn	JUMP n	JUMP to address	n PC	None

Note :

W	: Working register	b	: Bit position
WT	: Watchdog timer	t	: Target
TMODE	: TMODE mode register	0	: Working register
CPIO	: Control I/O port register	1	: General register
TF	: Timer overflow flag	R	: General register address
PF	: Power loss flag	C	: Carry flag
PC	: Program Counter	HC	: Half carry
OSC	: Oscillator	Z	: Zero flag
Inclu.	: Inclusive ‘ ’	/	: Complement
Exclu.	: Exclusive ‘ ’	x	: Don't care
AND	: Logic AND ‘ ’	i	: Immediate data ( 8 bits )
		n	: Immediate address

## 9. Electrical Characteristics

### (A) Operating Voltage & Frequency

$V_{dd}$  : 2.3 V ~ 6.0 V

Frequency : 0 Hz ~ 20 MHz

### (B) Input Voltage

@  $V_{dd}$  = 5.0 V, Temperature = 25

	Port	Min.	Max.
$V_{il}$	PA, PB, PC	$V_{ss}$	1.0 V
	RTCC, /MCLR	$V_{ss}$	1.0 V
$V_{ih}$	PA, PB, PC	2.0 V	$V_{dd}$
	RTCC, /MCLR	3.3 V	$V_{dd}$



**\* Threshold Voltage :**Port A, Port B, Port C  $V_{th} = 1.5\text{ V}$ RTCC, /MCLR  $V_{il} = 1.2\text{ V}$ ,  $V_{ih} = 3.1\text{ V}$  (Schmitt Trigger)**(C) Output Voltage**@  $V_{dd} = 5.0\text{ V}$ , Temperature = 25 , the typical value as followings :

PA, PB, PC Port	
$I_{oh} = -20.0\text{ mA}$	$V_{oh} = 3.40\text{ V}$
$I_{ol} = 20.0\text{ mA}$	$V_{ol} = 0.50\text{ V}$
$I_{oh} = -5.0\text{ mA}$	$V_{oh} = 4.50\text{ V}$
$I_{ol} = 5.0\text{ mA}$	$V_{ol} = 0.10\text{ V}$

**(D) Leakage Current**@  $V_{dd} = 5.0\text{ V}$ , Temperature = 25 , the typical value as followings :

$I_{il}$	- 0.1 $\mu\text{A}$ (Max.)
$I_{ih}$	+ 0.1 $\mu\text{A}$ (Max.)

**(E) Sleep Current**

@WDT - Disable, Temperature = 25 , the typical value as followings :

$V_{dd} = 2.3\text{ V}$	$I_{dd} < 1.0\ \mu\text{A}$
$V_{dd} = 3.0\text{ V}$	$I_{dd} < 1.0\ \mu\text{A}$
$V_{dd} = 4.0\text{ V}$	$I_{dd} < 1.0\ \mu\text{A}$
$V_{dd} = 5.0\text{ V}$	$I_{dd} < 1.0\ \mu\text{A}$
$V_{dd} = 6.0\text{ V}$	$I_{dd} < 1.0\ \mu\text{A}$

@WDT - Enable, Temperature = 25 , the typical value as followings :

$V_{dd} = 2.3\text{ V}$	$I_{dd} < 1.0\ \mu\text{A}$
$V_{dd} = 3.0\text{ V}$	$I_{dd} = 3.0\ \mu\text{A}$
$V_{dd} = 4.0\text{ V}$	$I_{dd} = 6.0\ \mu\text{A}$
$V_{dd} = 5.0\text{ V}$	$I_{dd} = 11.0\ \mu\text{A}$
$V_{dd} = 6.0\text{ V}$	$I_{dd} = 17.0\ \mu\text{A}$

## F) Operating Current

Temperature = 25 °C, the typical value as followings :

(i) OSC Type = RC (OSC1&OSC2 Internal Cap about 10P); WDT - Enable; @  $V_{dd} = 5.0$  V  
PED=Disable

Cext. (F)	Rext. (Ohm)	Frequency (Hz)	Current (A)
0P	4.7 K	7.76 M	980 $\mu$ A
	10.0 K	3.82 M	560 $\mu$ A
	47.0 K	848 K	240 $\mu$ A
	100.0 K	404 K	185 $\mu$ A
	300.0 K	135.6 K	155 $\mu$ A
	470.0 K	86 K	150 $\mu$ A
3P	4.7 K	6.8 M	880 $\mu$ A
	10.0 K	3.34 M	510 $\mu$ A
	47.0 K	740 M	230 $\mu$ A
	100.0 K	356 K	185 $\mu$ A
	300.0 K	119 K	155 $\mu$ A
	470.0 K	75.2 K	150 $\mu$ A
20P	4.7 K	4.16 M	610 $\mu$ A
	10.0 K	2.04 M	380 $\mu$ A
	47.0 K	452 K	200 $\mu$ A
	100.0 K	214.8 K	175 $\mu$ A
	300.0 K	75.2 K	155 $\mu$ A
	470.0 K	45.6 K	151 $\mu$ A
100P	4.7 K	1.57 M	335 $\mu$ A
	10.0 K	764 K	245 $\mu$ A
	47.0 K	167.2 K	175 $\mu$ A
	100.0 K	76.8 K	165 $\mu$ A
	300.0 K	26.6 K	160 $\mu$ A
	470.0 K	16.8 K	155 $\mu$ A

Cext. (F)	Rext. (Ohm)	Frequency (Hz)	Current (A)
300P	4.7 K	672 K	235 $\mu$ A
	10.0 K	321.6 K	195 $\mu$ A
	47.0 K	70.4 K	165 $\mu$ A
	100.0 K	33.2 K	160 $\mu$ A
	300.0 K	11.1 K	158 $\mu$ A
	470.0 K	7.04 K	156 $\mu$ A

(ii) OSC Type = LF (OSC1&OSC2 Internal Cap about 10P); WDT - Enable ;  
PED=Disable

Voltage/Frequency	32 K	455 K	1 M	Sleep
2.3 V	7.0 $\mu$ A	25.0 $\mu$ A	40.0 $\mu$ A	< 1.0 $\mu$ A
3.0 V	15.0 $\mu$ A	45.0 $\mu$ A	65.0 $\mu$ A	3.0 $\mu$ A
4.0 V	35.0 $\mu$ A	85.0 $\mu$ A	115.0 $\mu$ A	6.0 $\mu$ A
5.0 V	70.0 $\mu$ A	140.0 $\mu$ A	180.0 $\mu$ A	11.0 $\mu$ A
6.0 V	130.0 $\mu$ A	215.0 $\mu$ A	260.0 $\mu$ A	17.0 $\mu$ A

(iii) OSC Type = XT (OSC1&OSC2 Internal Cap about 10P); WDT - Enable ; PED=Disable

Voltage/Frequency	1 M	4 M	10 M	Sleep
2.1 V	50.0 $\mu$ A	120.0 $\mu$ A	290 $\mu$ A	< 1.0 $\mu$ A
3.0 V	100.0 $\mu$ A	230.0 $\mu$ A	490 $\mu$ A	3.0 $\mu$ A
4.0 V	210.0 $\mu$ A	400.0 $\mu$ A	650 $\mu$ A	6.0 $\mu$ A
5.0 V	375.0 $\mu$ A	590.0 $\mu$ A	1.3 mA	11.0 $\mu$ A
6.0 V	645.0 $\mu$ A	850.0 $\mu$ A	1.6 mA	17.0 $\mu$ A

(iv) OSC Type = HF (OSC1&OSC2 Internal Cap about 10P); WDT - Enable ; PED=Disable

Voltage/Frequency	4 M	10 M	20 M	Sleep
2.1 V	150.0 $\mu$ A	320.0 $\mu$ A	X	< 1.0 $\mu$ A
3.0 V	280.0 $\mu$ A	550.0 $\mu$ A	950.0 $\mu$ A	3.0 $\mu$ A
4.0 V	510.0 $\mu$ A	910.0 $\mu$ A	1.5 mA	6.0 $\mu$ A
5.0 V	800.0 $\mu$ A	1.4 mA	2.3 mA	11.0 $\mu$ A
6.0 V	1.3 mA	1.9 mA	3.2 mA	17.0 $\mu$ A

(G) Power Edge-detector Reset Voltage (Not in Sleep Mode), @  $V_{dd} = 5.0$  V

$V_{pr}$  1.8~2.2 V

$V_{pr} : V_{dd}$  (Power Supply)

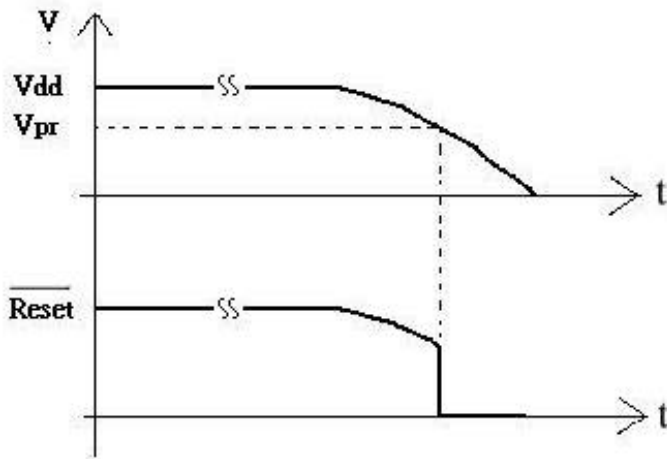

(H) The basic WDT time-out cycle time

@Temperature = 25 , the typical value as followings :

$V_{dd} = 5.0$  V, Temperature=25 , the typical value as followings:

Voltage (V)	Basic WDT time-out cycle time (ms)
2.3	25.2
3.0	22.4
4.0	20.4
5.0	18.8
6.0	18.0

10. Port A ,Port B and Port C Equivalent Circuit

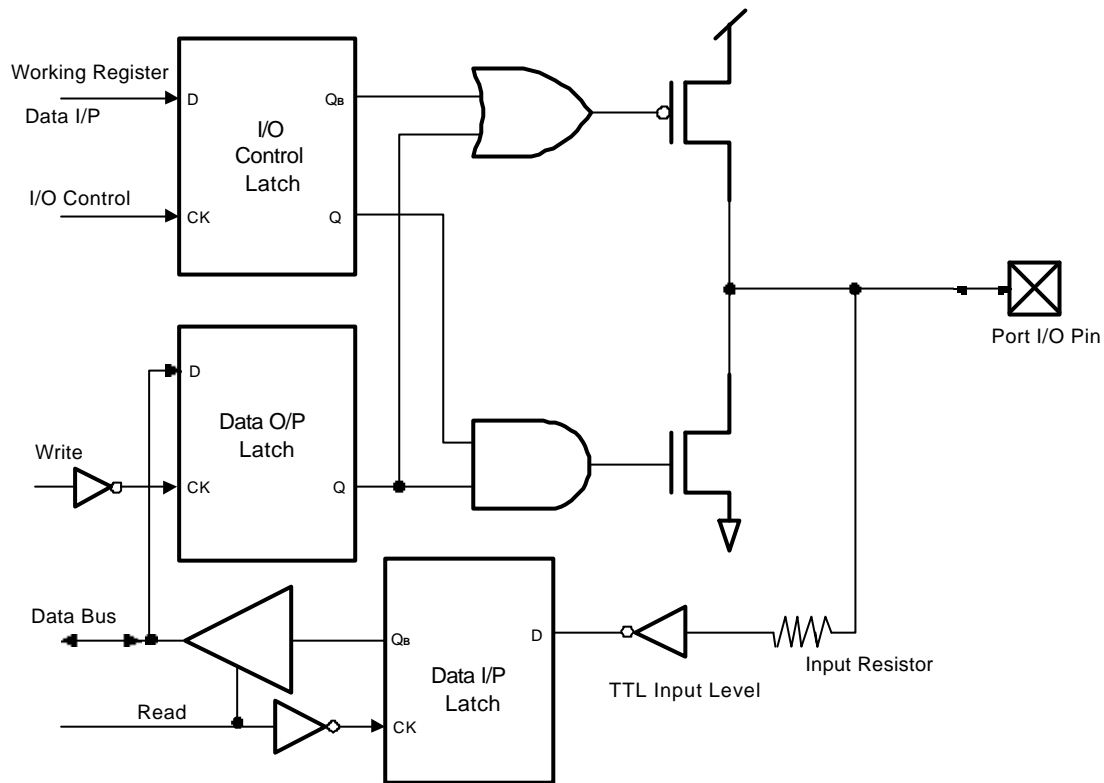

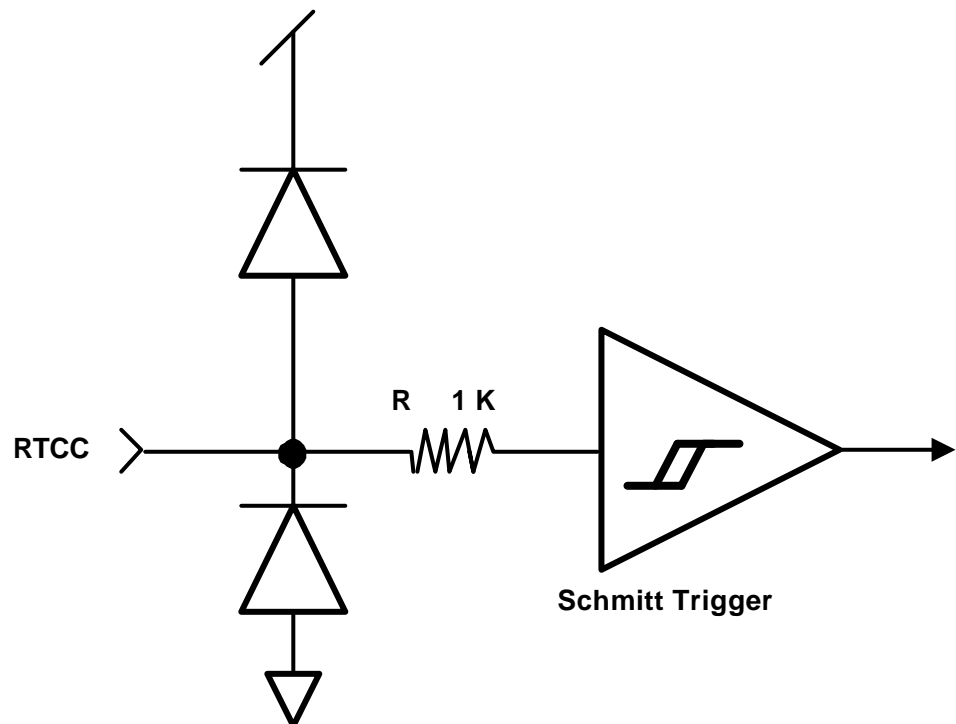
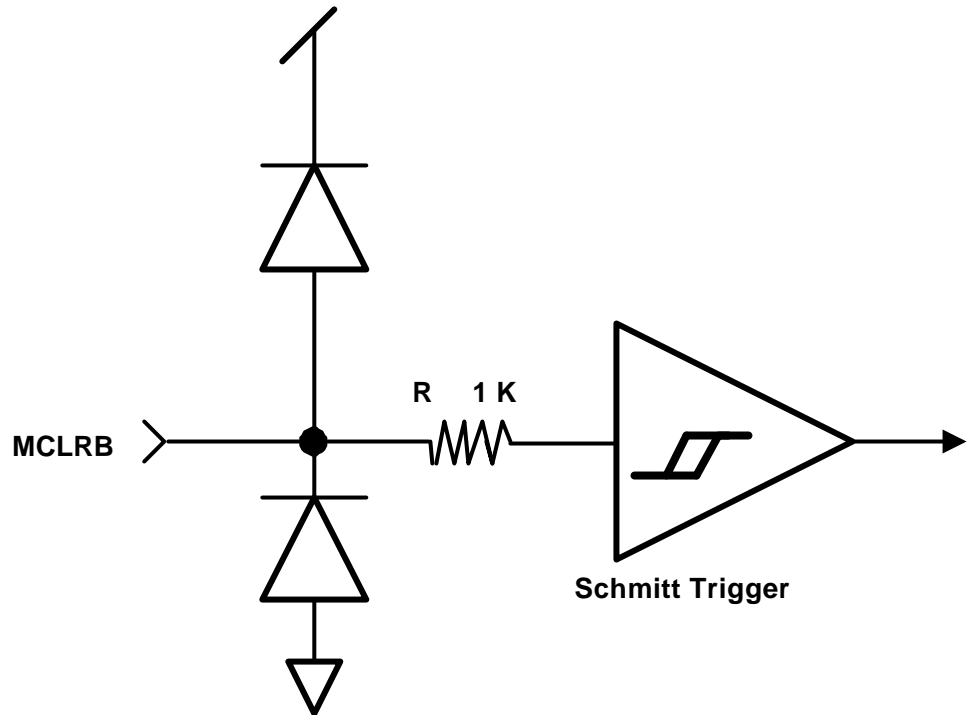
**11. MCLRB and RTCC Input Equivalent Circuit**

12. Block Diagram

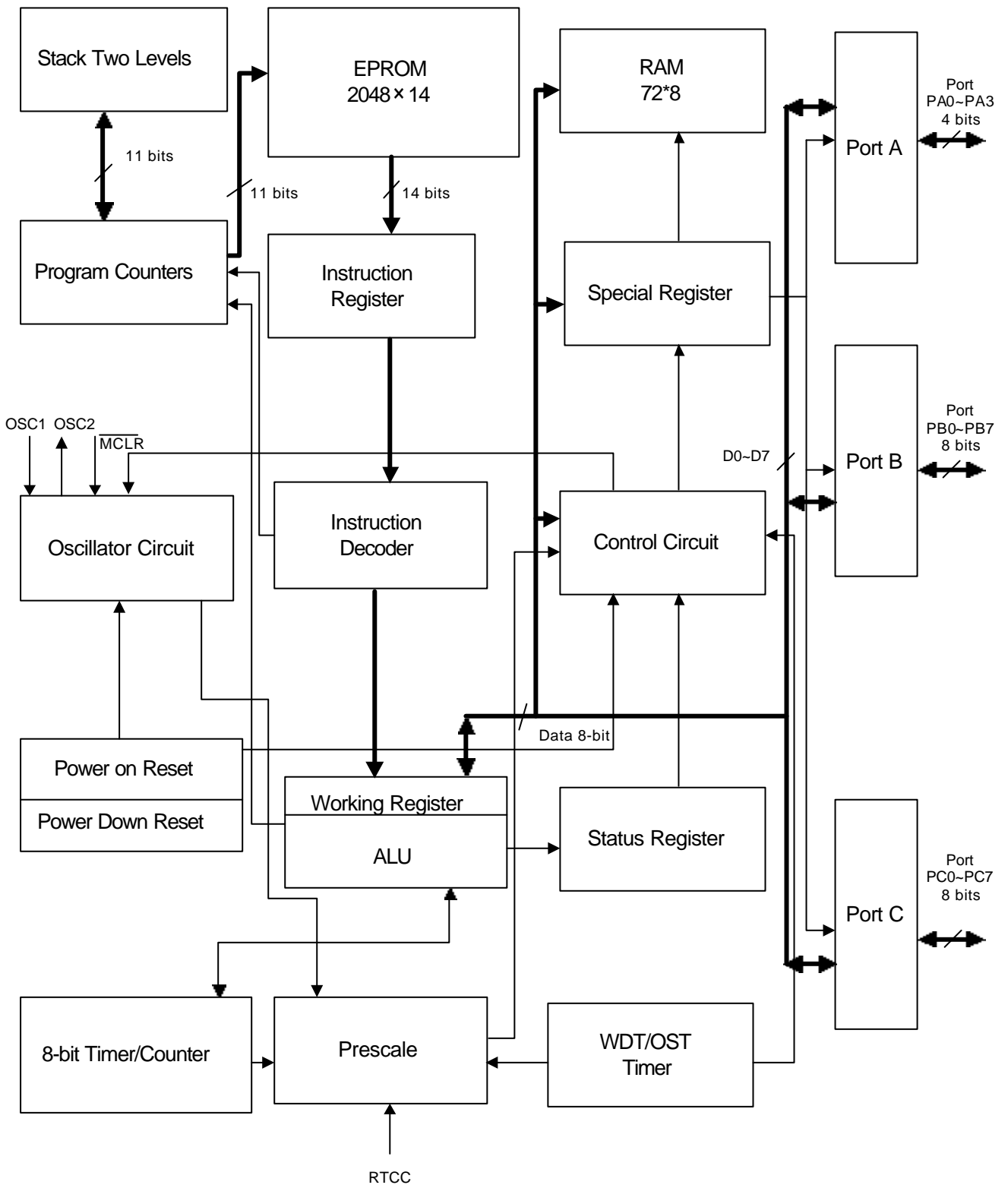

**13. External Capacitor Selection For Crystal Oscillator**

@  $V_{dd} = 3.0\text{ V} \sim 5.0\text{ V}$

Osc. Type	Resonator Freq.	C1	C2
HF	20 MHz	5 pF ~10 pF	10 pF~30 pF
	10 MHz	10 pF ~50 pF	20 pF ~100 pF
	4 MHz	10 pF ~50 pF	20 pF ~100 pF
XT	10 MHz	10 pF ~30 pF	10 pF ~50 pF
	4 MHz	10 pF ~50 pF	20 pF ~100 pF
	1 MHz	10 pF ~30 pF	20 pF ~50 pF
LF	1 MHz	3 pF ~5 pF	3 pF ~5 pF
	455 K	10 pF ~30 pF	20 pF ~50 pF
	32 K	10 pF ~20 pF	15 pF ~30 pF

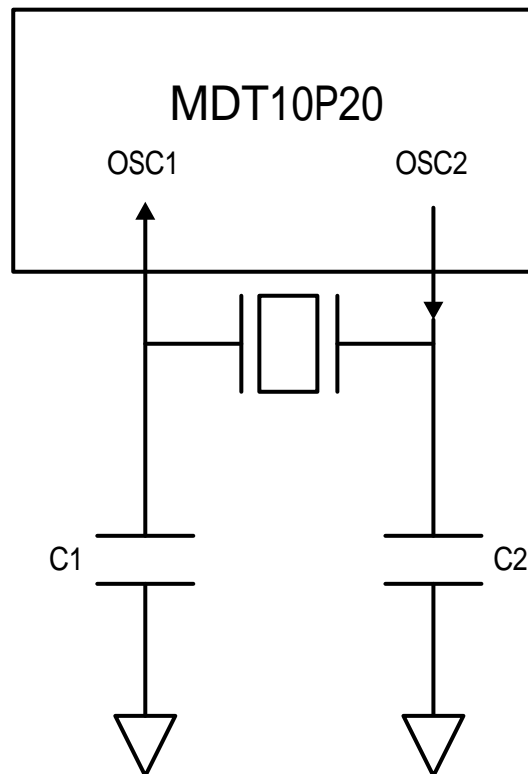

To increase the stability of oscillator and the ability of anti-noise, the above values of the external capacitor range can be recommended for reference, but the higher capacitance also increases the start-up time.