

1

PRODUCT OVERVIEW

SAM87RI PRODUCT FAMILY

Samsung's SAM87Ri family of 8-bit single-chip CMOS microcontrollers offers a fast and efficient CPU, a wide range of integrated peripherals, and various mask-programmable ROM sizes.

A address/data bus architecture and a large number of bit-configurable I/O ports provide a flexible programming environment for applications with varied memory and I/O requirements. Timer/counters with selectable operating modes are included to support real-time operations.

KS86C4204/C4208/P4208 MICROCONTROLLER

The KS86C4204/C4208/P4208 single-chip 8-bit microcontroller is fabricated using an advanced CMOS process. It is built around the powerful SAM87Ri CPU core. The KS86C4204/C4208/P4208 is a versatile microcontroller, with its A/D converter, SIO, IIC and a zero-crossing detection capability it can be used in a wide range of general purpose applications.

Stop and Idle power-down modes were implemented to reduce power consumption. To increase on-chip register space, the size of the internal register file was logically expanded. The KS86C4204/C4208/P4208 have 4-Kbyte or 8-Kbyte of program memory on-chip (ROM) and 208-bytes of general purpose register area RAM.

Using the SAM87Ri design approach, the following peripherals were integrated with the SAM87Ri core:

- Four configurable I/O ports (24 pins)
- Nine interrupt sources with one vector and one interrupt level
- Two 8-bit timer/counter with various operating modes
- Analog to digital converter with 12 input channels and 10-bit resolution
- One synchronous SIO module
- One IIC module
- Two 12-bit PWM output

The KS86C4204/C4208/P4208 microcontroller is ideal for use in a wide range of electronic applications requiring simple timer/counter, PWM, ADC, SIO, IIC, ZCD and capture functions. KS86C4204/C4208/P4208 is available in a 28/32-pin SOP and a 30-pin SDIP package.

OTP

The KS86P4208 is an OTP (One Time Programmable) version of the KS86C4204/C4208 microcontroller. The KS86P4208 has on-chip 8-Kbyte one-time-programmable EPROM instead of masked ROM. The KS86P4208 is fully compatible with the KS86C4204/C4208, in function, in D.C. electrical characteristics and in pin configuration.

FEATURES

CPU

- SAM87RI CPU core

Memory

- 208-byte general purpose register area (RAM)
- 4K/8K byte internal program memory (ROM)

Instruction Set

- 41 instructions
- The SAM87RI core provides all the SAM87 core instruction except the word-oriented instruction, multiplication, division, and some one-byte instruction

Instruction Execution Time

- 375 ns at 16 MHz fosc(minimum)

Interrupts

- 9 interrupt sources and 1 vector
- One interrupt level

General I/O

- Four I/O ports (total 24pins)
- Bit programmable ports

Serial I/O

- One synchronous serial I/O module
- Selectable transmit and receive rates

Multi-Master IIC-Bus

- Serial peripheral interface

Zero-Crossing Detection Circuit

- Zero crossing detection circuit that generates a digital signal in synchronism with an AC signal input

Built-in reset Circuit (LVD)

- Low voltage detector for safe reset

Timer/Counters

- One 8-bit basic timer for watchdog function
- One 8-bit timer/counter with three operating mode
- One 8-bit timer/counter

PWM module

- 12-bit PWM 2-ch (Max: 250KHz)
- 6-bit base + 6-bit extension frame
- One 8-bit timer/counter

A/D Converter

- 12 analog input pins
- 10-bit conversion resolution

Buzzer Frequency Range

- 200 Hz to 20 kHz signal can be generated

Oscillator Frequency

- 1-MHz to 16-MHz external crystal oscillator
Maximum 16-MHz CPU clock
- RC: 4MHz(typ)

Operating Temperature Range

- -40°C to $+85^{\circ}\text{C}$

Operating Voltage Range

- 3.0 V to 5.5 V (LVD)
- 1.8 V to 5.5 V (No LVD)

OTP Interface Protocol Spec

- Serial OTP

Package Types

- KS86C4204/C4208
32-pin SOP-450 (3V LVD)
30-pin SDIP-400 (3V LVD)
28-pin SOP-375

BLOCK DIAGRAM

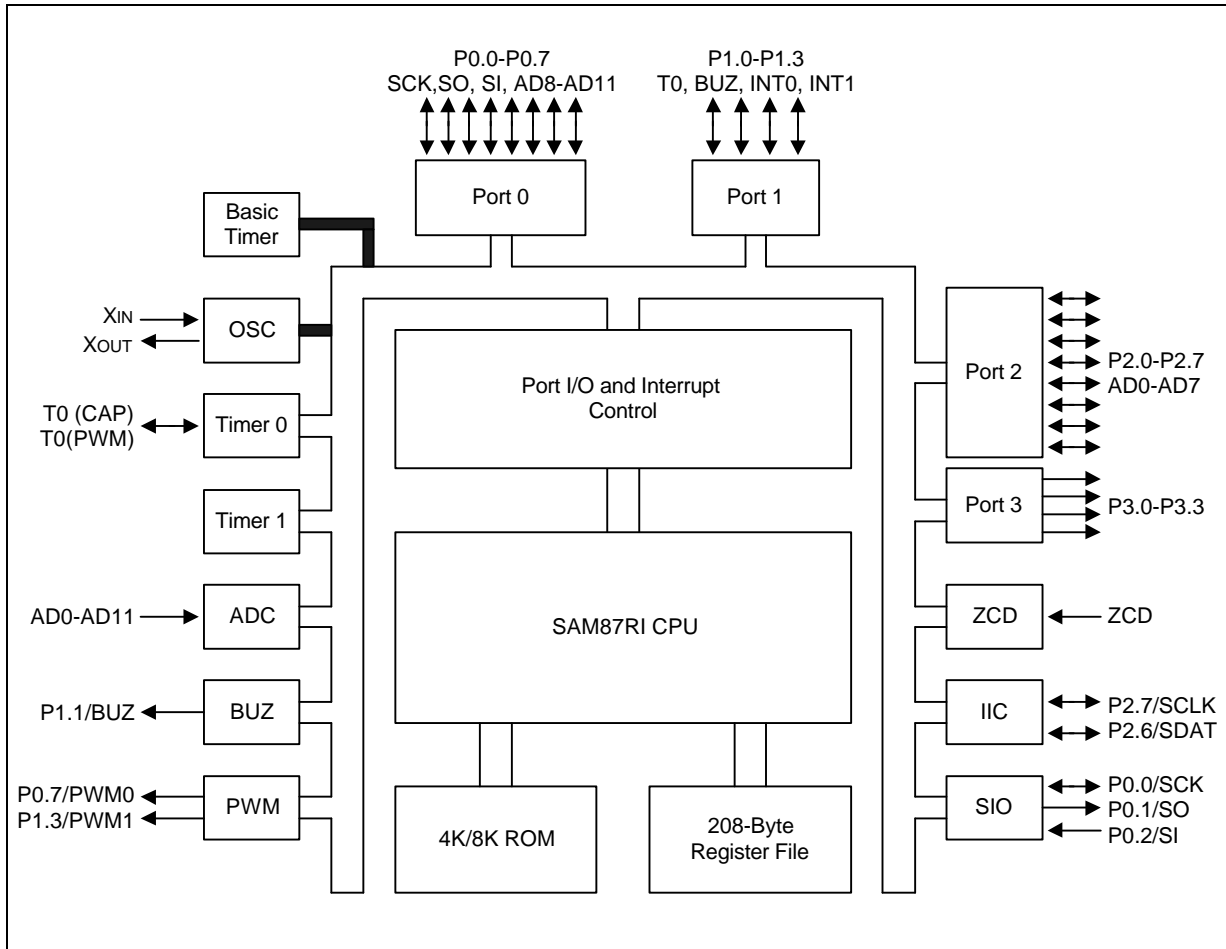

Figure 1-1. Block Diagram

PIN ASSIGNMENTS

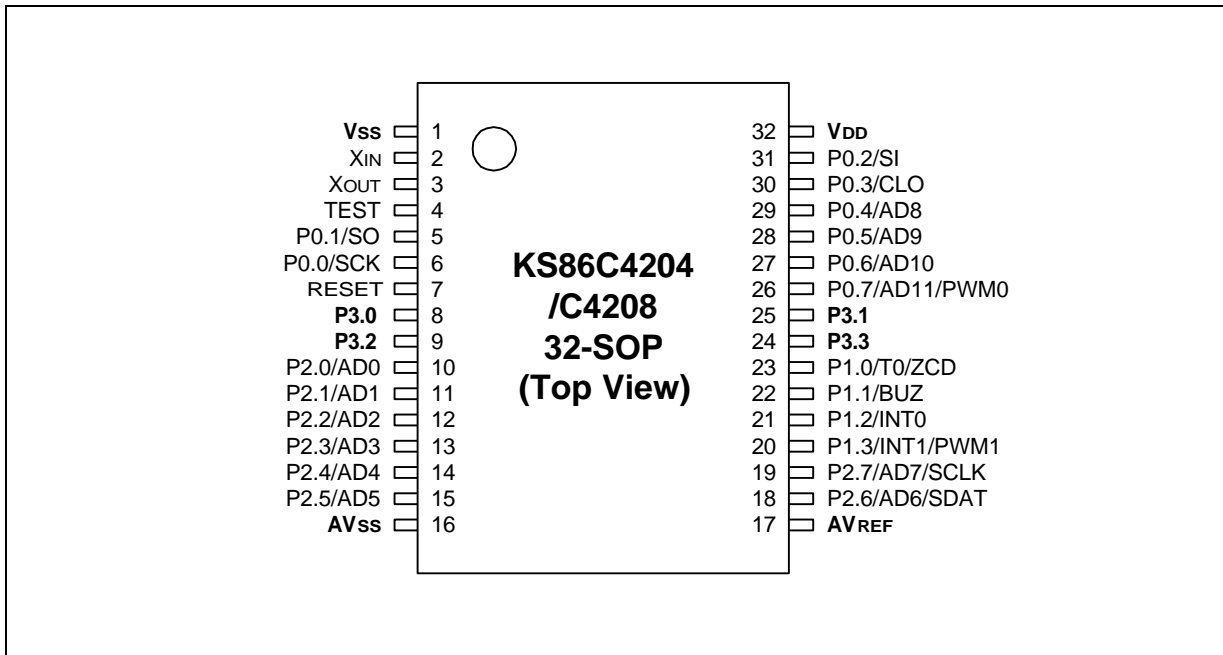

Figure 1-2. Pin Assignment Diagram (32-Pin SOP Package)

PIN ASSIGNMENTS (Continued)

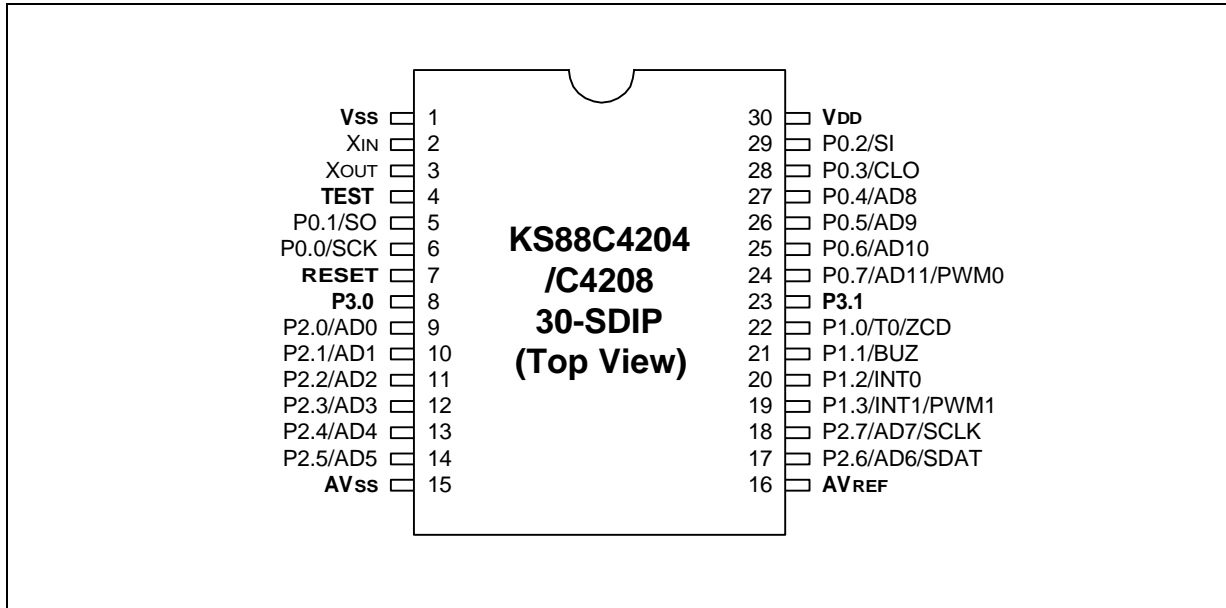

Figure 1-3. Pin Assignment Diagram (30-Pin SDIP Package)

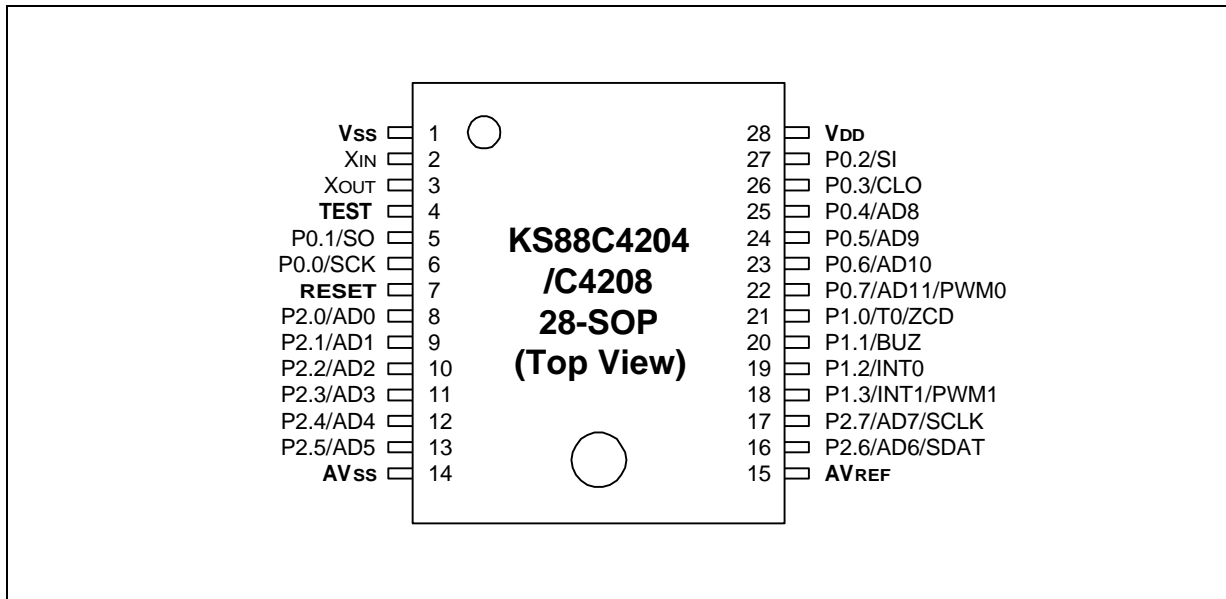

Figure 1-4. Pin Assignment Diagram (28-Pin SOP Package)

PIN DESCRIPTIONS

Table 1-1. KS86C4204/C4208/P4208 Pin Descriptions

Pin Names	Pin Type	Pin Description	Pin Type	Share Pins
P0.0-P0.7	I/O	Bit-programmable I/O port for Schmitt trigger input or push-pull, open-drain output. Pull-up resistors are assignable by software.	E E-1	SCK, SO, SI , CLO, AD8-AD11
P1.0-P1.3	I/O	Bit-programmable I/O port for Schmitt trigger input or push-pull output. Pull-up resistors are assignable by software. Port 1 pins can also be used as alternative functions.	D	T0/ZCD BUZ INT0 INT1
P2.0-P2.7	I/O	Bit-programmable I/O port for Schmitt trigger input or push-pull, open drain output. Pull up resistors are assignable by software. Port 2 can also be used as external interrupt, A/D input.	E-1	AD0-AD7
P3.0-P3.3	O	Push-pull or open-drain output port. Pull-up resistors are assignable by software.	E-2	–
X _{IN} , X _{OUT}	–	Crystal/ceramic, or RC oscillator signal for system clock.	–	–
RESET	I	System RESET signal input pin.	B	–
TEST	I	Test signal input pin (for factory use only: must be connected to V _{SS})	–	–
AV _{REF} , AV _{SS}	–	A/D converter reference voltage input and ground	–	–
V _{DD} , V _{SS}	–	Voltage input pin and ground	–	–
SCK	I/O	Serial interface clock input or output	E	P0.0
SO	O	Serial data output	E	P0.1
SI	I	Serial data output	E	P0.2
CLO	O	System clock output port	E	P0.3
SCLK SDAT	I/O	IIC CLOCK IIC DATA	E-1	P2.7 P2.6
BUZ	O	200 Hz-20 kHz frequency output for buzzer sound.	D	P1.1
ZCD	I	Zero crossing detector input	D	P1.0
T0	I/O	Timer 0 capture input or 10-bit PWM output	D	P1.0
INT0 INT1	I	External interrupt input	D	P1.2 P1.3
PWM0 PWM1	O	12-bit PWM output	E-1 D	P0.7 P1.3
AD0-AD11	I	A/D converter input	E-1	P2.0-P2.7 P0.4-P0.7

PIN CIRCUITS

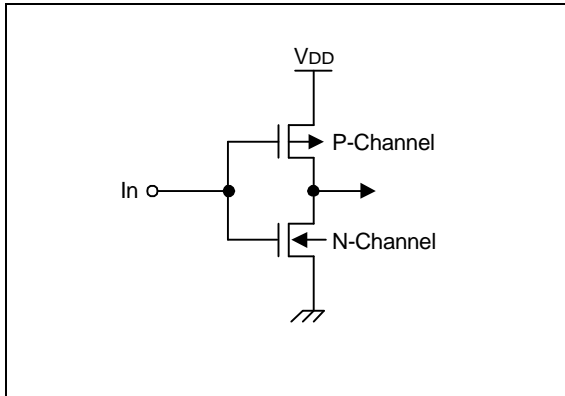

Figure 1-5. Pin Circuit Type A

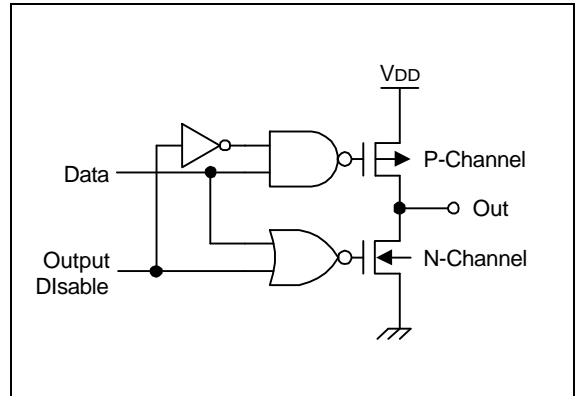

Figure 1-7. Pin Circuit Type C

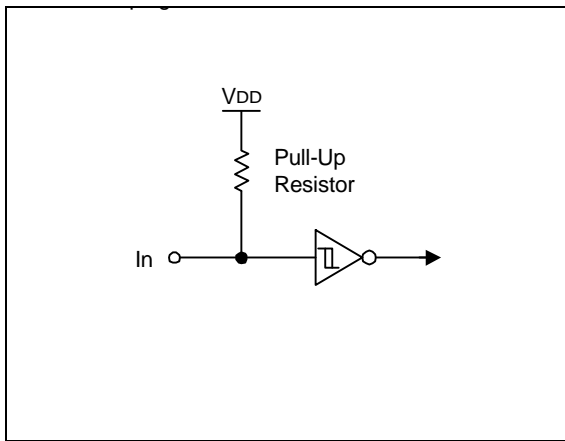

Figure 1-6. Pin Circuit Type B

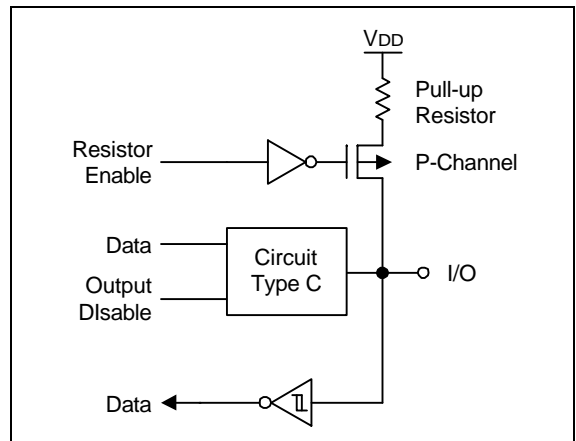

Figure 1-8. Pin Circuit Type D

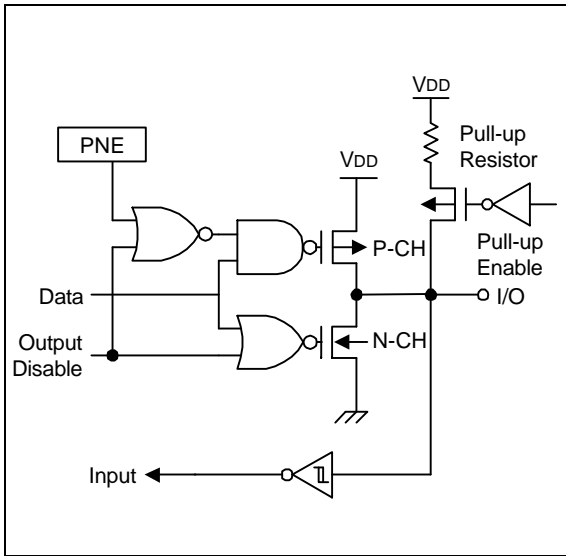

Figure 1-9. Pin Circuit Type E

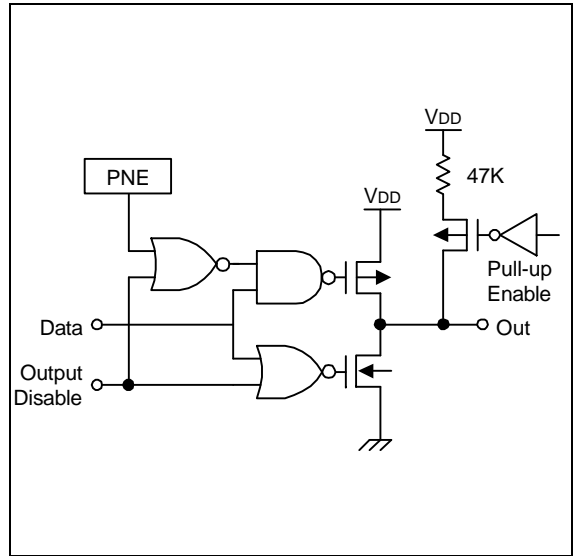

Figure 1-11. Pin Circuit Type E-2

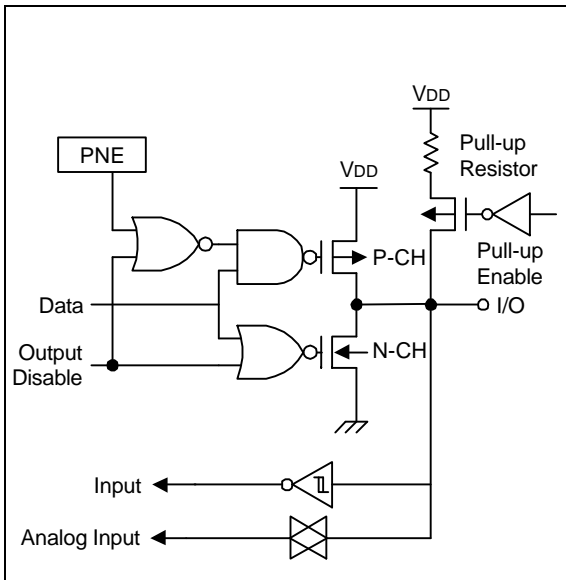

Figure 1-10. Pin Circuit Type E-1

16 ELECTRICAL DATA

OVERVIEW

In this section, the following KS86C4204/C4208/P4208 electrical characteristics are presented in tables and graphs:

- Absolute maximum ratings
- D.C. electrical characteristics
- A.C. electrical characteristics
- Operating Voltage Range
- Schmitt trigger input characteristics
- Oscillator characteristics
- Oscillation stabilization time
- Data retention supply voltage in Stop mode
- Stop mode release timing when initiated by a RESET
- Power-on RESET circuit characteristics
- A/D converter electrical characteristics
- Zero-crossing detector
- Zero Crossing Waveform Diagram

Table 16-1. Absolute Maximum Ratings

 $(T_A = 25^\circ\text{C})$

Parameter	Symbol	Conditions	Rating	Unit
Supply voltage	V_{DD}	–	– 0.3 to + 6.5	V
Input voltage	V_I	All input ports	– 0.3 to $V_{DD} + 0.3$	V
Output voltage	V_O	All output ports	– 0.3 to $V_{DD} + 0.3$	V
Output current high	I_{OH}	One I/O pin active	– 25	mA
		All I/O pins active	– 80	
Output current low	I_{OL}	One I/O pin active	+ 30	mA
		Total pin current for ports 1, 2, 3	+ 100	
		Total pin current for ports 0	+ 200	
Operating temperature	T_A	–	– 40 to + 85	$^\circ\text{C}$
Storage temperature	T_{STG}	–	– 65 to + 150	$^\circ\text{C}$

Table 16-2. D.C. Electrical Characteristics(30SDIP, 32SOP)

(T_A = -40°C to +85°C, V_{DD} = 3.0 V to 5.5 V)

Parameter	Symbol	Conditions	Min	Typ	Max	Unit	
Input high voltage	V _{IH1}	Ports 0, 1, 2 and RESET	V _{DD} = 3.0 to 5.5 V	0.8 V _{DD}	–	V _{DD}	V
	V _{IH3}	X _{IN} and X _{OUT}		V _{DD} - 0.1			
Input low voltage	V _{IL1}	Ports 0, 1, 2 and RESET	V _{DD} = 3.0 to 5.5 V	–	–	0.2 V _{DD}	V
	V _{IL2}	X _{IN} and X _{OUT}				0.1	
Output high voltage	V _{OH}	I _{OH} = -10 mA ports 0-3	V _{DD} = 4.5 to 5.5 V	V _{DD} - 1.5	V _{DD} - 0.4	–	V
Output low voltage	V _{OL}	I _{OL} = 25 mA port 0-3	V _{DD} = 4.5 to 5.5 V	–	0.4	2.0	V
Input high leakage current	I _{LIH1}	All input pins except I _{LIH2}	V _{IN} = V _{DD}	–	–	1	μA
	I _{LIH2}	X _{IN} , X _{OUT}	V _{IN} = V _{DD}			20	
Input low leakage current	I _{LIL1}	All input pins except I _{LIL2} and RESET	V _{IN} = 0 V	–	–	-1	μA
	I _{LIL2}	X _{IN} , X _{OUT}	V _{IN} = 0 V			-20	
Output high leakage current	I _{LOH}	All output pins	V _{OUT} = V _{DD}	–	–	2	μA
Output low leakage current	I _{LOL}	All output pins	V _{OUT} = 0 V	–	–	-2	μA
Pull-up resistor	R _P	V _{IN} = 0 V Port 0-2	V _{DD} = 5 V	30	47	70	KΩ
		RESET	V _{DD} = 5 V	100	200	350	
Supply current	I _{DD1}	RUN mode 16-MHz CPU clock	V _{DD} = 4.5 to 5.5 V	–	11	20	mA
		4-MHz CPU clock	V _{DD} = 3 V		1.5	4	
	I _{DD2}	Idle mode 16-MHz CPU clock	V _{DD} = 4.5 to 5.5 V	–	3	8	
		4-MHz CPU clock	V _{DD} = 3.3 V		0.5	2	
	I _{DD3}	Stop mode	V _{DD} = 4.5 to 5.5 V	–	65	100	μA
V _{DD} = 3.3 V				45	80		

NOTE: D.C. electrical values for Supply current (I_{DD1} to I_{DD3}) do not include current drawn through internal pull-up resistors, output port drive current, ZCD and ADC.

Table 16-3. D.C. Electrical Characteristics (28SOP)

(T_A = -40°C to +85°C, V_{DD} = 1.8 V to 5.5 V)

Parameter	Symbol	Conditions	Min	Typ	Max	Unit		
Input high voltage	V _{IH1}	Ports 0, 1, 2 and RESET	V _{DD} = 1.8 to 5.5 V	0.8 V _{DD}	-	V _{DD}	V	
	V _{IH3}	X _{IN} and X _{OUT}		V _{DD} - 0.1				
Input low voltage	V _{IL1}	Ports 0, 1, 2 and RESET	V _{DD} = 1.8 to 5.5 V	-	-	0.2 V _{DD}	V	
	V _{IL2}	X _{IN} and X _{OUT}				0.1		
Output high voltage	V _{OH}	I _{OH} = -10 mA ports 0-3	V _{DD} = 4.5 to 5.5 V	V _{DD} - 1.0	V _{DD} - 0.4	-	V	
Output low voltage	V _{OL}	I _{OL} = 25 mA port 0-3	V _{DD} = 4.5 to 5.5 V	-	0.4	2.0	V	
Input high leakage current	I _{LIH1}	All input pins except I _{LIH2}	V _{IN} = V _{DD}	-	-	1	μA	
	I _{LIH2}	X _{IN} , X _{OUT}	V _{IN} = V _{DD}			20		
Input low leakage current	I _{LIL1}	All input pins except I _{LIL2} and RESET	V _{IN} = 0 V	-	-	-1	μA	
	I _{LIL2}	X _{IN} , X _{OUT}	V _{IN} = 0 V			-20		
Output high leakage current	I _{LOH}	All output pins	V _{OUT} = V _{DD}	-	-	2	μA	
Output low leakage current	I _{LOL}	All output pins	V _{OUT} = 0 V	-	-	-2	μA	
Pull-up resistor	R _P	V _{IN} = 0 V Port 0-2	V _{DD} = 5 V	30	47	70	KΩ	
		RESET	V _{DD} = 5 V	100	200	350		
Supply current	I _{DD1}	RUN mode 16-MHz CPU clock	V _{DD} = 4.5 to 5.5 V	-	11	20	mA	
		3-MHz CPU clock	V _{DD} = 1.8 to 2.2 V			1		3
	I _{DD2}	Idle mode 16-MHz CPU clock	V _{DD} = 4.5 to 5.5 V	-	3	9		
		3-MHz CPU clock	V _{DD} = 1.8 to 2.2 V			0.3		1.0
	I _{DD3}	Stop mode	V _{DD} = 4.5 to 5.5 V	-	0.1	5		μA
			V _{DD} = 3 V					
V _{DD} = 1.8 to 2.2 V								

NOTE: D.C. electrical values for Supply current (I_{DD1} to I_{DD3}) do not include current drawn through internal pull-up resistors, output port drive current, ZCD and ADC.

Table 16-4. A.C. Electrical Characteristics

($T_A = -40^{\circ}\text{C}$ to $+85^{\circ}\text{C}$, $V_{DD} = 1.8\text{ V}$ to 5.5 V)

Parameter	Symbol	Conditions	Min	Typ	Max	Unit
Interrupt input high, low width	t_{INTH} , t_{INTL}	Port 1v(INT0, INT1) $V_{DD} = 5V \pm 10\%$	–	200	–	ns
RESET input low width	t_{RSL} –	Input $V_{DD} = 5V \pm 10\%$	–	1	–	us

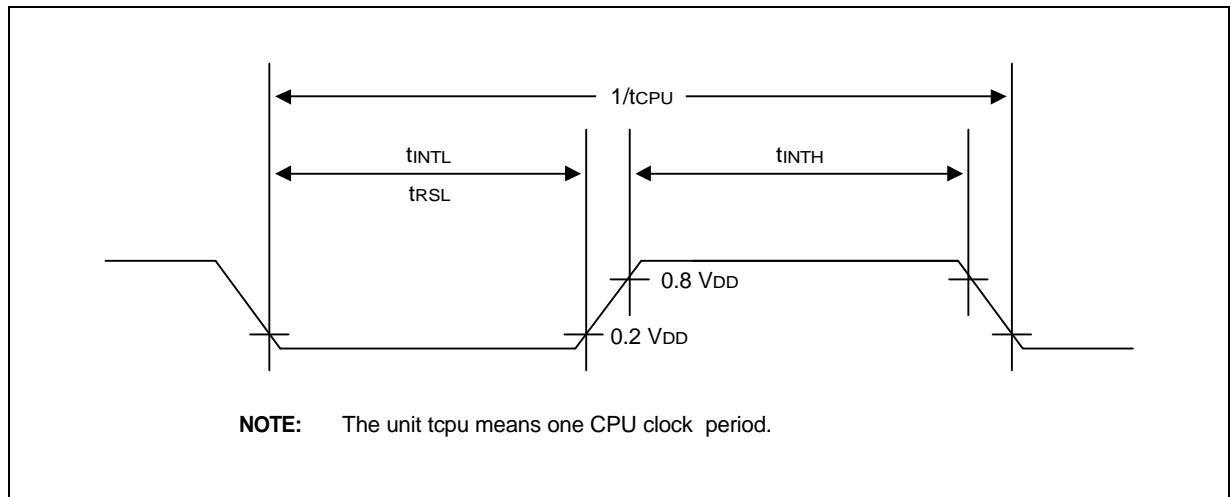

Figure 16-1. Input Timing Measurement Points

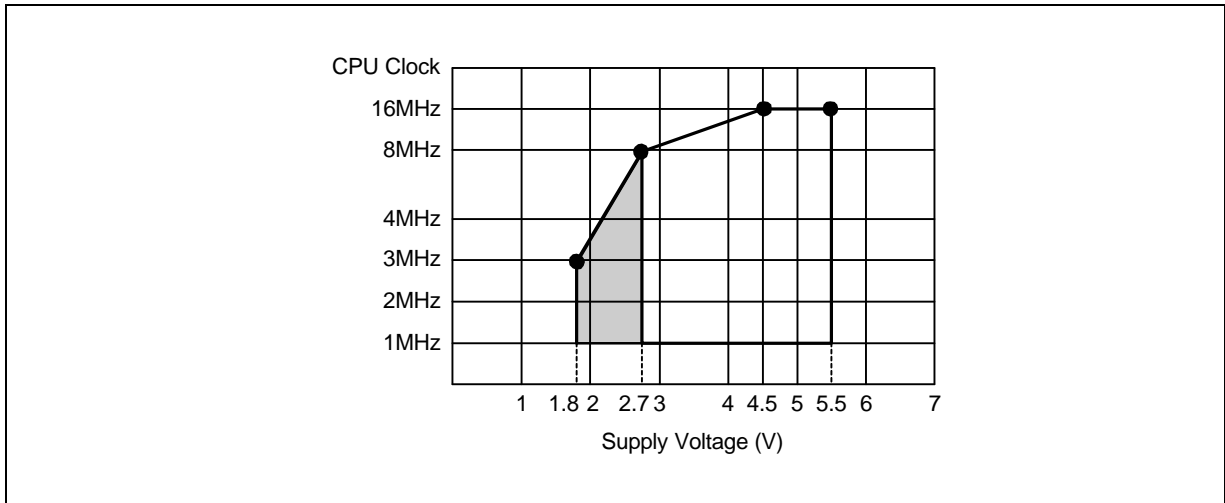

Figure 16-2. Operating Voltage Range (KS86C4204/C4208)

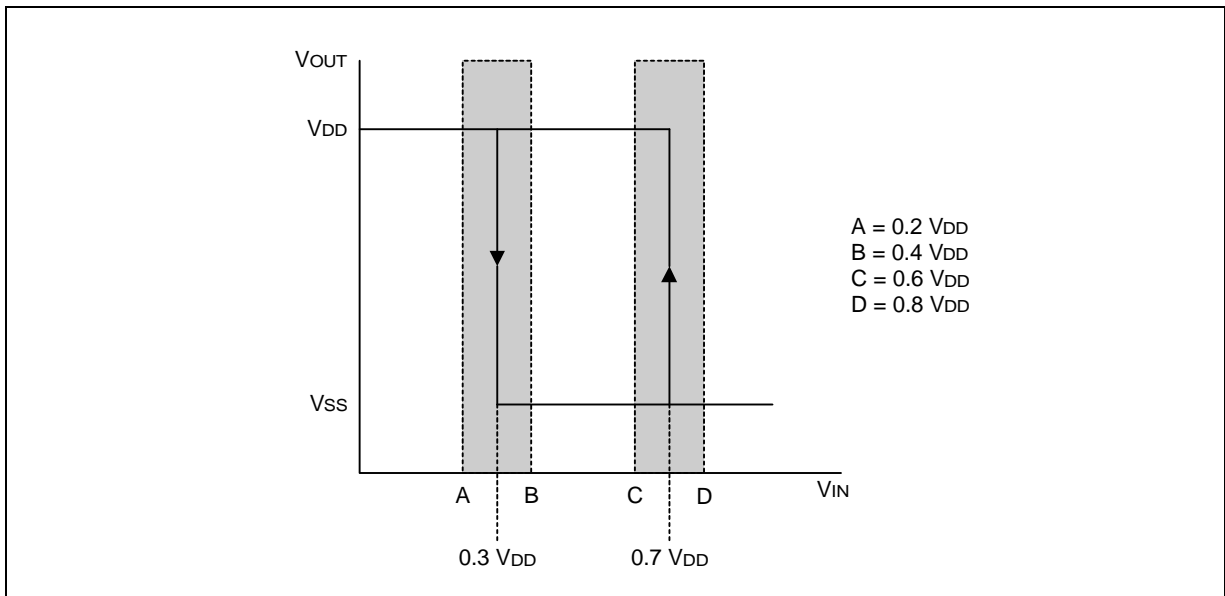

Figure 16-3. Schmitt Trigger Input Characteristic Diagram

Table 16-5. Oscillator Characteristics (30SDIP, 32SOP)

(T_A = -40°C to +85°C)

Oscillator	Clock Circuit	Test Condition	Min	Typ	Max	Unit
Main crystal or ceramic		V _{DD} = 4.5 to 5.5 V V _{DD} = 3.0 to 4.5 V	1 1	- -	16 8	MHz
External clock (Main system)		V _{DD} = 4.5 to 5.5 V V _{DD} = 3.0 to 4.5 V	1 1	- -	16 8	
RC oscillator		V _{DD} = 4.75 to 5.25 V Tolerance: 10%	-	4	-	

Table 16-6. Oscillation Stabilization Time (28SOP)

(T_A = -40°C to +85°C)

Oscillator	Clock Circuit	Test Condition	Min	Typ	Max	Unit
Main crystal or ceramic		V _{DD} = 4.5 to 5.5 V V _{DD} = 2.7 to 4.5 V V _{DD} = 1.8 to 2.7 V	1 1 1	- - -	16 8 3	MHz
External clock (Main system)		V _{DD} = 4.5 to 5.5 V V _{DD} = 2.7 to 4.5 V V _{DD} = 1.8 to 2.7 V	1 1 1	- - -	16 8 3	
RC oscillator		V _{DD} = 4.75 to 5.25 V Tolerance: 10%	-	4	-	

Table 16-7. Oscillation Stabilization Time

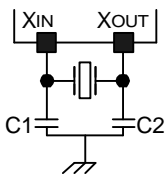
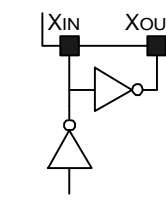
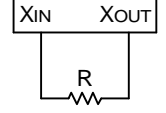
(T_A = -40°C to +85°C, V_{DD} = 1.8 V to 5.5 V)

Oscillator	Test Condition	Min	Typ	Max	Unit
Main crystal	fosc > 1.0 MHz	–	–	20	ms
Main ceramic	Oscillation stabilization occurs when V _{DD} is equal to the minimum oscillator voltage range.	–	–	10	
External clock (main system)	X _{IN} input high and low width (t _{XH} , t _{XL})	25	–	500	ns
Oscillator stabilization wait time	t _{WAIT} when released by a reset ⁽¹⁾	–	2 ¹⁶ /fosc	–	ms
	t _{WAIT} when released by an interrupt ⁽²⁾	–	–	–	

NOTES:

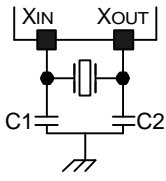
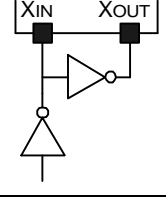
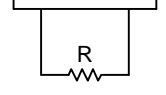
- fosc is the oscillator frequency.
- The duration of the oscillator stabilization wait time, t_{WAIT}, when it is released by an interrupt is determined by the setting in the basic timer control register, BTCON.

Table 16-8. Data Retention Supply Voltage in Stop Mode

($T_A = -40^{\circ}\text{C}$ to $+85^{\circ}\text{C}$, $V_{DD} = 1.8\text{ V}$ to 5.5V)

Parameter	Symbol	Conditions	Min	Typ	Max	Unit
Data retention supply voltage	V_{DDDR}	Stop mode	1.8	–	5.5	V
Data retention supply current	I_{DDDR}	Stop mode; $V_{DDDR} = 1.8\text{ V}$	–	0.1	5	μA

NOTE: Supply current does not include current drawn through internal pull-up resistors or external output current loads.

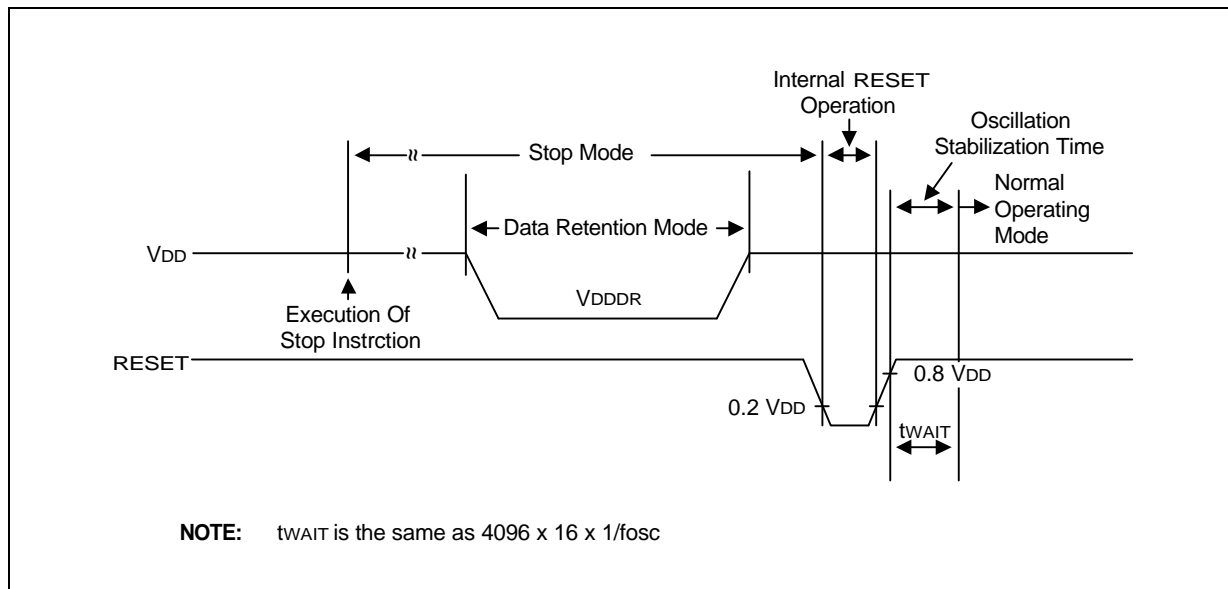

Figure 16-4. Stop Mode Release Timing When Initiated by a RESET

Table 16-9. Power-on RESET Circuit Characteristics(T_A = -40 °C to +85 °C, V_{DD} = 3.0 V to 5.5 V)

Parameter	Symbol	Conditions	Min	Typ	Max	Unit
Power-on reset voltage high	V _{DDH}		3.0	–	5.5	V
Power-on reset voltage low	V _{DDL}		0	2.6	3.0	V
Power supply voltage rise time	t _r		10		(1)	us
Power supply voltage off time	t _{off}		0.5			s
Power-on reset circuit consumption current (2)	I _{DDPR}	V _{DD} = 5 V ± 10%		65	100	μA
		V _{DD} = 3.3 V		45	80	

NOTES:

- 216/f_x (= 6.55 ms at f_x = 10 MHz)
- Current consumed when power-on reset circuit is provided internally.

**Figure16-5. Power-on RESET Timing**

Table 16-10. A/D Converter Electrical Characteristics

($T_A = -40^{\circ}\text{C}$ to $+85^{\circ}\text{C}$, $V_{DD} = 1.8/3.0\text{ V}$ to 5.5 V , $V_{SS} = 0\text{ V}$)

Parameter	Symbol	Test Conditions	Min	Typ	Max	Unit
Total accuracy		$V_{DD} = 5.12\text{ V}$ CPU clock = 10 MHz $AV_{REF} = 5.12\text{ V}$ $AV_{SS} = 0\text{ V}$	-	-	± 3	LSB
Integral linearity error	ILE	"	-	-	± 2	LSB
Differential linearity error	DLE	"	-	-	± 1	
Offset error of top	EOT	"	-	± 1	± 3	
Offset error of bottom	EOB	"	-	± 1	± 2	
Conversion time ⁽¹⁾	t_{CON}	fosc = 10 MHz	20	-	-	μs
Analog input voltage	V_{IAN}	-	AV_{SS}	-	AV_{REF}	V
Analog input impedance	R_{AN}	-	2	-	-	M Ω
ADC reference voltage	AV_{REF}	-	2.5	-	V_{DD}	V
ADC reference ground	AV_{SS}	-	V_{SS}	-	$V_{SS} + 0.3$	V
Analog input current	I_{ADIN}	$AV_{REF} = V_{DD} = 5\text{ V}$	-	-	10	μA
ADC block current ⁽²⁾	I_{ADC}	$AV_{REF} = V_{DD} = 5\text{ V}$	-	1	3	mA
		$AV_{REF} = V_{DD} = 3\text{ V}$	-	0.5	1.5	
		$AV_{REF} = V_{DD} = 5\text{ V}$ Power down mode	-	100	500	nA

NOTES:

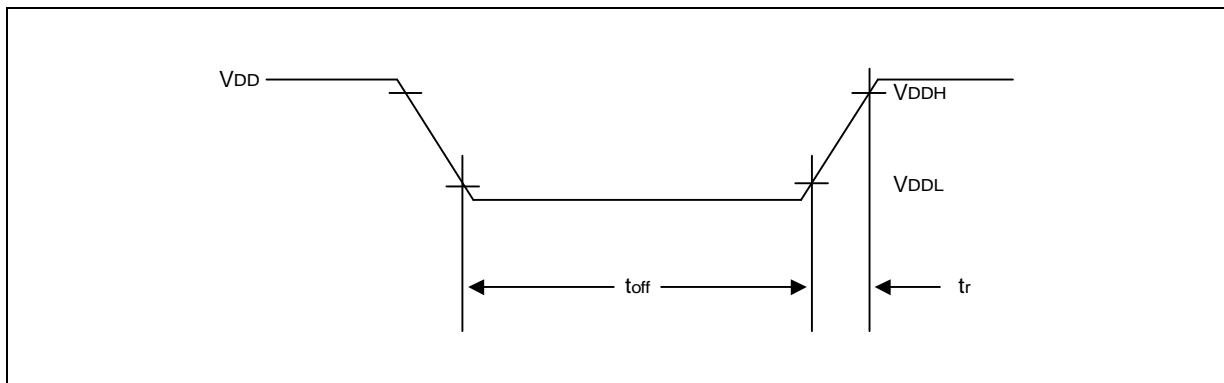
1. 'Conversion time' is the time required from the moment a conversion operation starts until it ends.
2. I_{ADC} is operating current during A/D conversion.

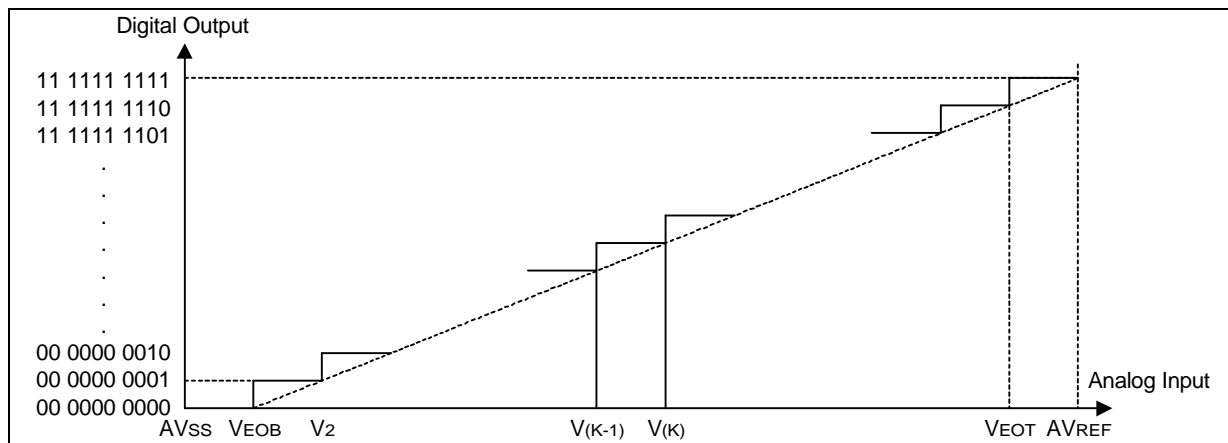

Figure 16-6. Definition of DLE and ILE

Table 16-11. Zero Crossing Detector

(T_A = -40°C to +85°C, V_{DD} = 4.5 V to 5.5 V, V_{SS} = 0 V)

Parameter	Symbol	Test Conditions	Min	Typ	Max	Unit
Zero-crossing detection input voltage	V _{ZC}	AC connection c = 0.1 μF	1.0	–	3.0	Vp-p
Zero-crossing detection accuracy	V _{AZC}	f _{ZC} = 60 Hz (sine wave) V _{DD} = 5 V f _{OSC} = 10 MHz	–	–	± 150	mV
Zero-crossing detection input frequency	f _{ZC}	–	40	–	200	Hz

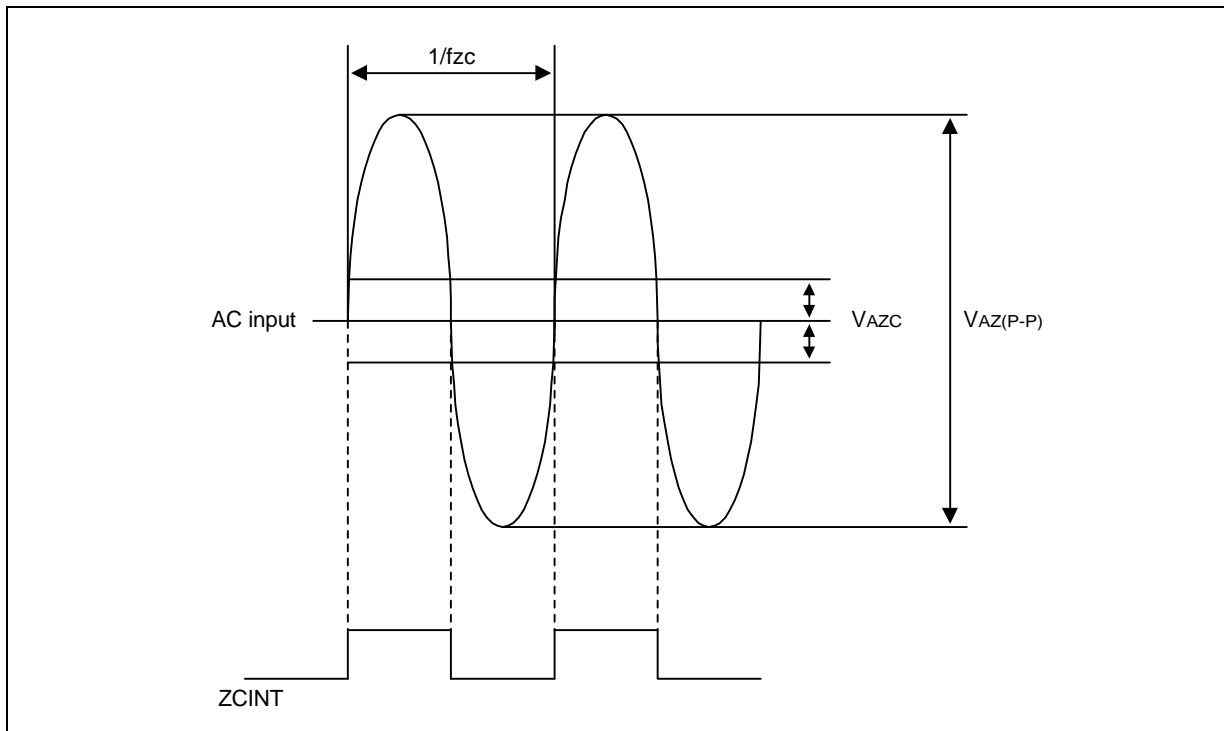

Figure 16-7. Zero Crossing Waveform Diagram

17 MECHANICAL DATA

OVERVIEW

The KS86C4204/C4208 is available in a 30-pin SDIP package (Samsung: 30-SDIP-400) and a 32-pin SOP package (32-SOP-450A) and a 28-pin SOP package (28-SOP-375). Package dimensions are shown in Figures 17-1, 17-2, and 17-3

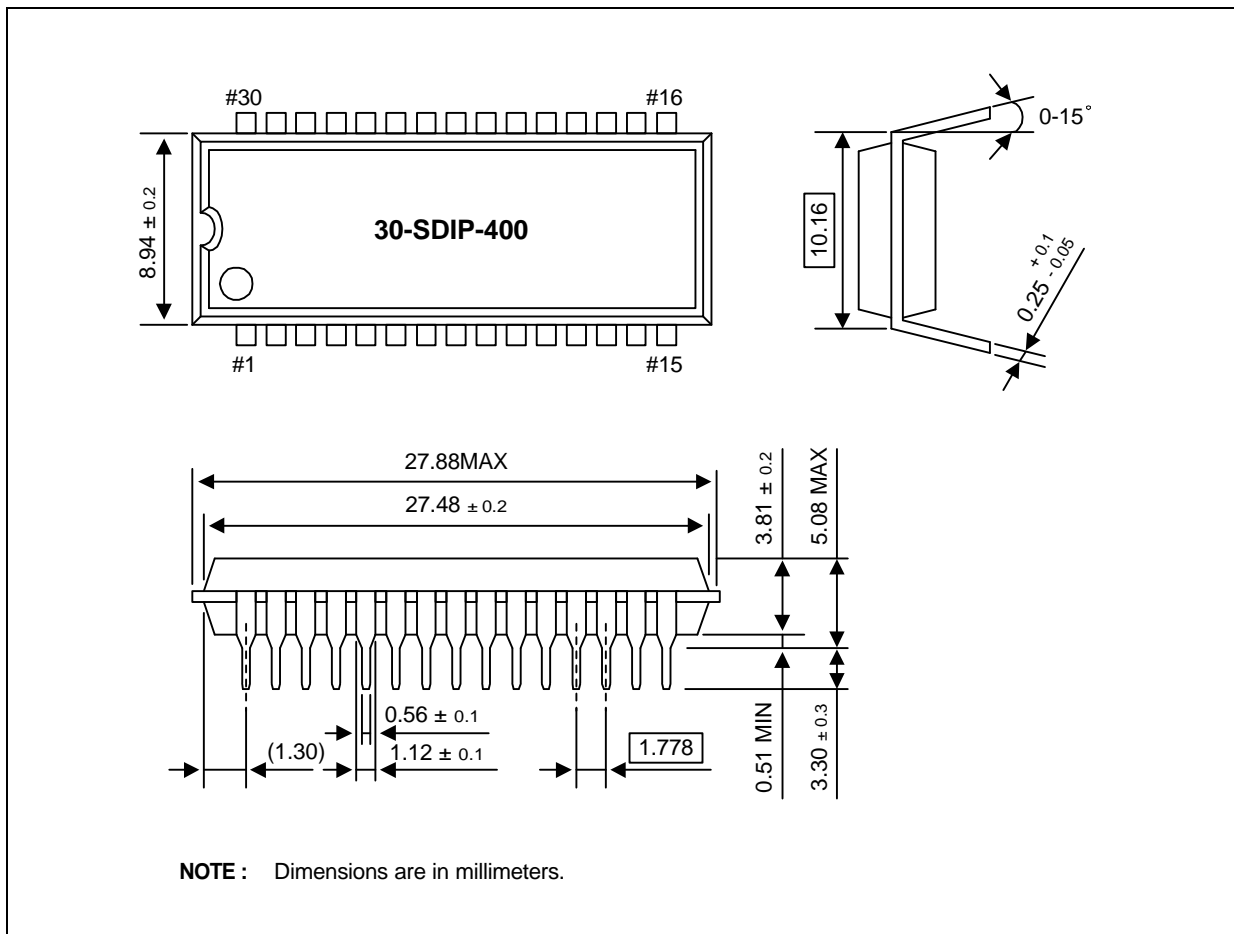

Figure 17-1. 30-Pin SDIP Package Dimensions

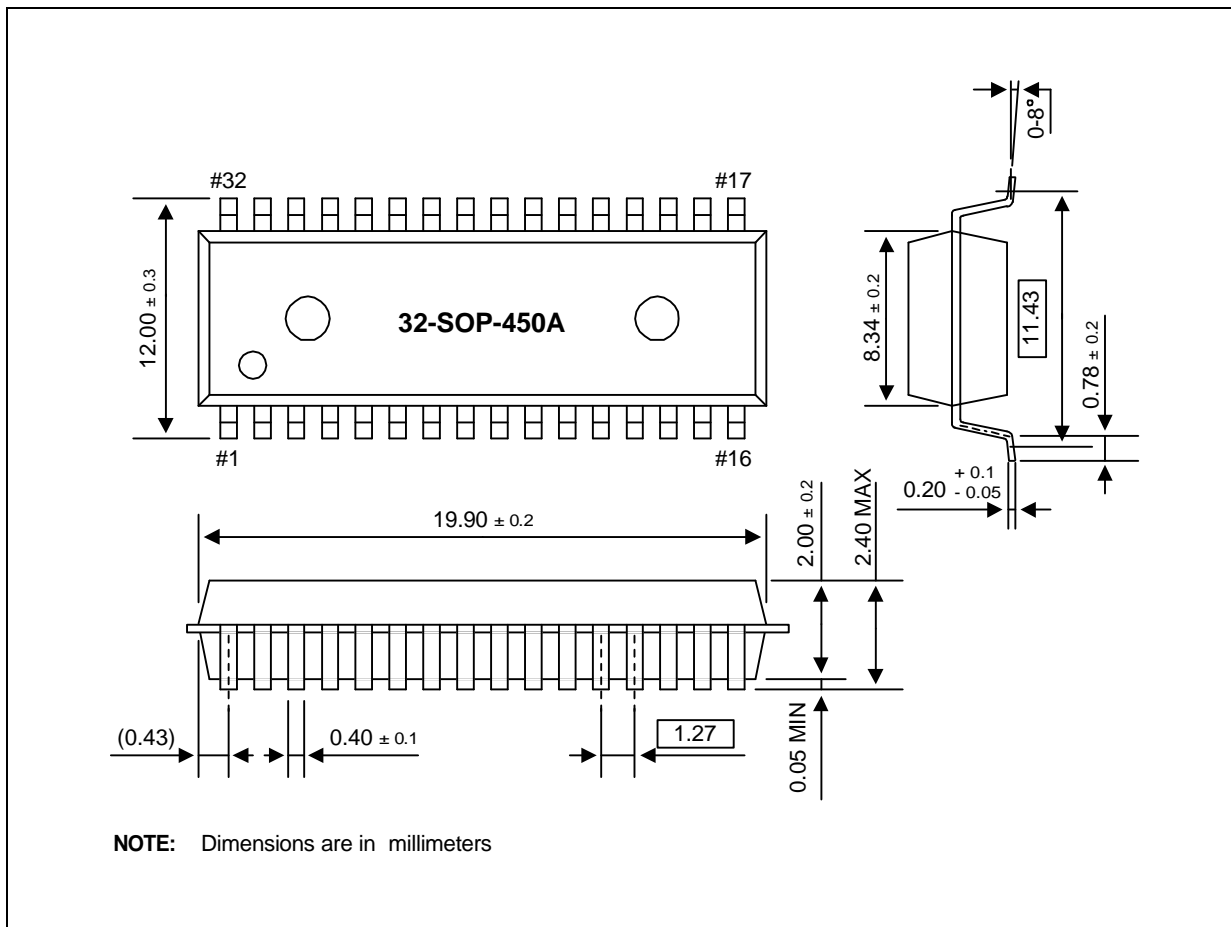

Figure 17-2. 32-SOP-450A Package Dimensions

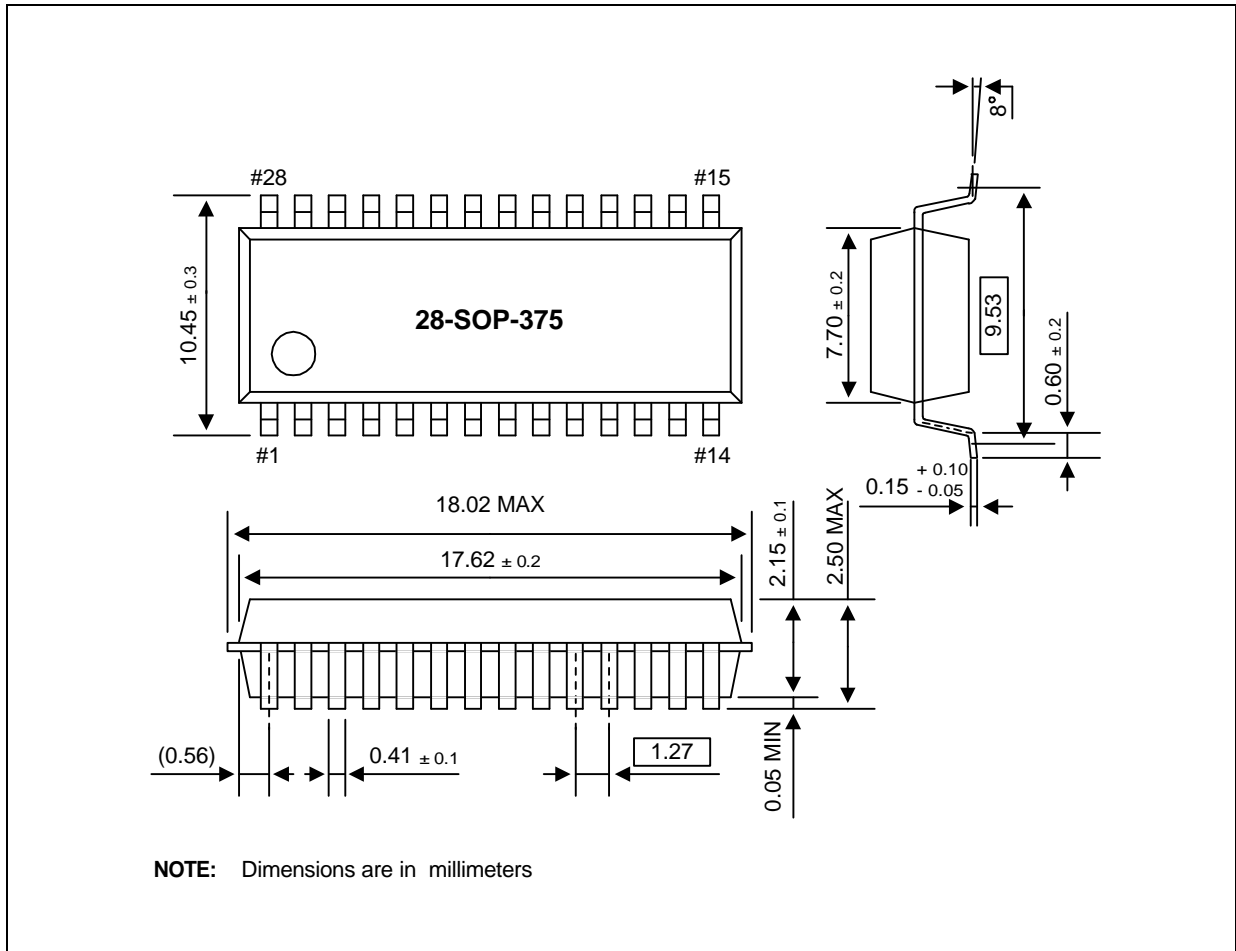

Figure 17-3. 28-SOP-375 Package Dimensions

NOTES

18

KS86P4208 OTP

OVERVIEW

The KS86P4208 single-chip CMOS microcontroller is the OTP (One Time Programmable) version of the KS86C4204/C4208 microcontroller. It has an on-chip OTP ROM instead of masked ROM. The EPROM is accessed by serial data format.

The KS86P4208 is fully compatible with the KS86C4204/C4208, both in function and in pin configuration. Because of its simple programming requirements, the KS86P4208 is ideal for use as an evaluation chip for the KS86C4204/C4208.

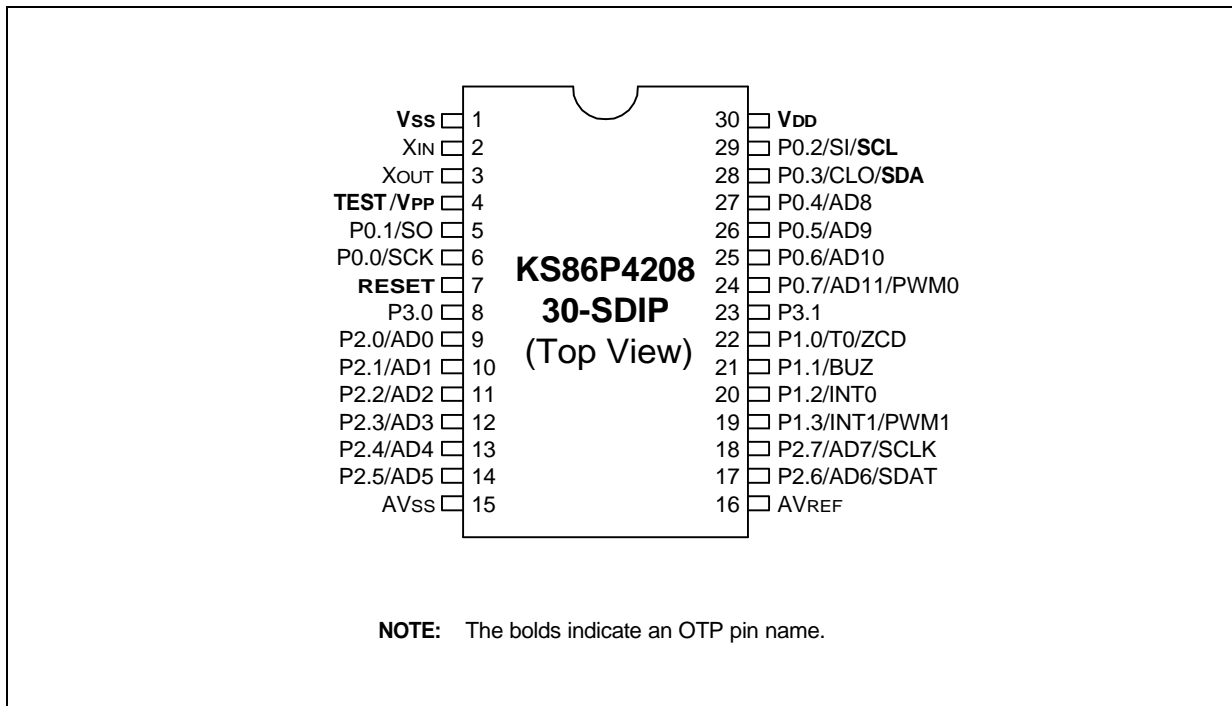

Figure 18-1. Pin Assignment Diagram (30-Pin SDIP Package)

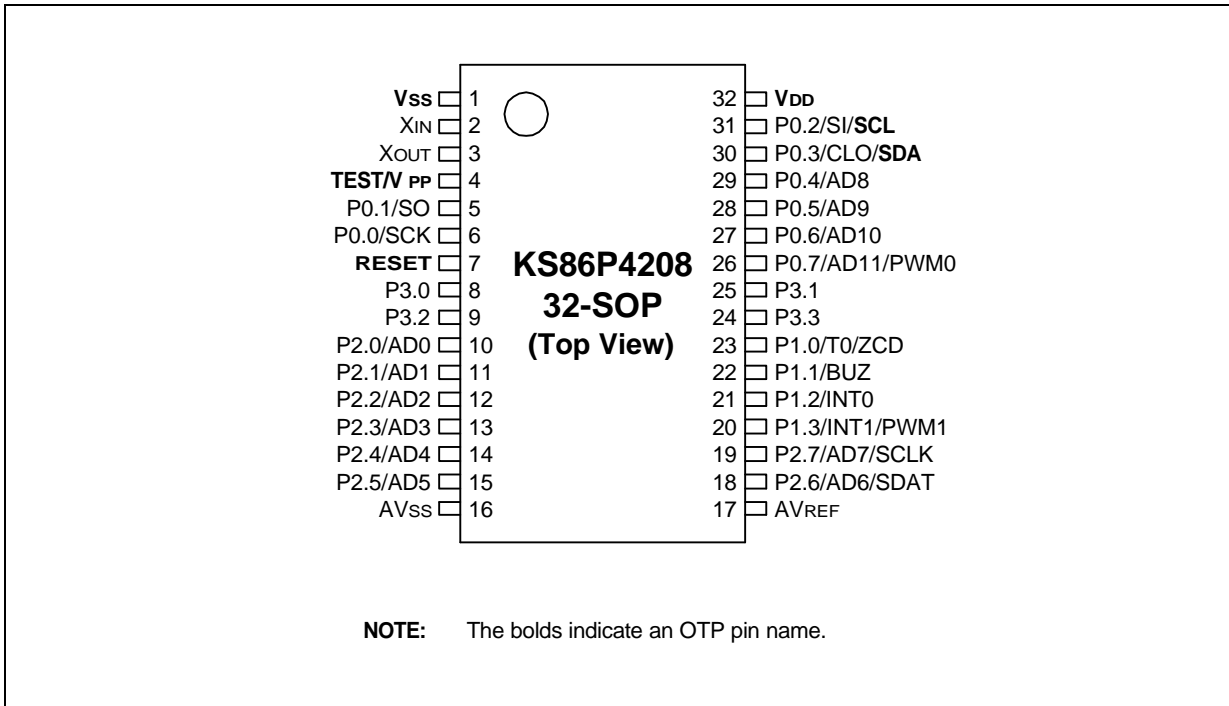

Figure 18-2. Pin Assignment Diagram (32-Pin SOP Package)

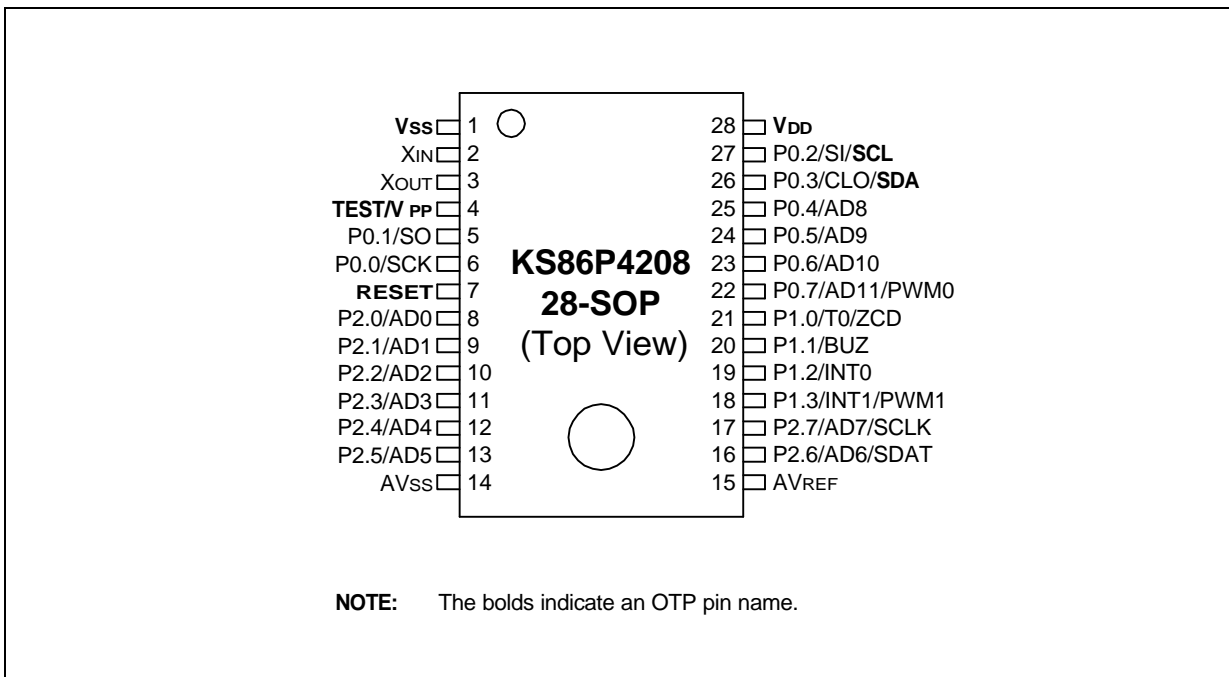

Figure 18-3. Pin Assignment Diagram (28-Pin SOP Package)

Table 18-1. Descriptions of Pins Used to Read/Write the EPROM

Main Chip Pin Name	During Programming			
	Pin Name	Pin No.	I/O	Function
P0.3	SDAT	KS86P4208 - 30 SDIP: 28 - 32 SOP: 30	I/O	Serial data pin (output when reading, Input when writing) Input and push-pull output port can be assigned
P0.2	SCLK	KS86P4208 - 30 SDIP: 29 - 32 SOP: 31	I	Serial clock pin (input only pin)
TEST	V _{PP} (TEST)	4	I	Power supply pin for EPROM cell writing (indicates that OTP enters into the writing mode). When 12.5 V is applied, OTP is in writing mode and when 5 V is applied, OTP is in reading mode. (Option)
RESET	RESET	7	I	Chip Initialization
V _{DD} /V _{SS}	V _{DD} /V _{SS}	KS86P4208 - 30 SDIP: 30/1 - 32 SOP: 32/1	I	Logic power supply pin.

Table 18-2. Comparison of KS86P4208 and KS86C4204/C4208 Features

Characteristic	KS86P4208	KS86C4204/C4208
Program Memory	8-Kbyte EPROM	4/8-Kbyte mask ROM
Operating Voltage (V _{DD})	3.0 V to 5.5 V (28 SOP: 1.8 V to 5.5)	3.0 V to 5.5 V (28 SOP: 1.8 V to 5.5)
OTP Programming Mode	V _{DD} = 5 V, V _{PP} (TEST) = 12.5 V	
Pin Configuration	30 SDIP/32 SOP/28SOP	
EPROM Programmability	User Program 1 time	Programmed at the factory

OPERATING MODE CHARACTERISTICS

When 12.5 V is supplied to the V_{PP} (TEST) pin of the KS86P4208, the EPROM programming mode is entered. The operating mode (read, write, or read protection) is selected according to the input signals to the pins listed in Table 18-3 below.

Table 18-3. Operating Mode Selection Criteria

V _{DD}	V _{pp} (TEST)	REG/MEM	ADDRESS(A15-A0)	R/W	MODE
5 V	5 V	0	0000H	1	EPROM read
	12.5 V	0	0000H	0	EPROM program
	12.5 V	0	0000H	1	EPROM verify
	12.5 V	1	0E3FH	0	EPROM read protection

NOTE: "0" means Low level; "1" means High level.

NOTES