

Schottky Barrier Diodes

$V_{RM}: 30 \sim 90V$ $I_o: 0.7 \sim 30A$

SFPB/AK/EK/RK/FMB/CTB/RBA/RBV

Rating/ Characteristics	Absolute Maximum Ratings							Electrical Characteristics (Ta = 25°C)						Others			
	V _{RSM} (V)	V _{RM}	I _o (A)	I _{FSM} (A)	I ² t (A ² S)	T _J (°C)	T _{stg} (°C)	V _F (V)		I _R (mA)	I _{R(H)} (mA)	t _{rr} (μs)	R _{th(j-θ)} (°C/W)	Outline Drawing	Weight(g)	Taping	Note
Type No.	Per chip		with Fin	50Hz Half Sine Wave Single Pulse				Max. per chip	I _F (A)	V _R = V _{RM} max (per chip)	V _R = V _{RM} , T _J = 125°C max (per chip)	I _F /I _{RP} (mA)					
SFPB-54	45	40	1.0	60				0.55	1.0	1.0	50	0.05					
SFPB-64	45	40	1.5						0.62								
SFPB-56	60	60	0.7	10				0.62	0.7		7.5						
SFPB-59	90	90							0.81								
AK 03	35	30	1.0	25				0.6	1.0		50 (T _J = 100°C)	0.1					
AK 04	45	40							0.62								
AK 06	60	60	0.7	10				0.62	0.7		5.0						
AK 09	90	90							0.81								
EK 03	35	30	1.0	40				0.55	1.5	5.0	50	0.2					
EK 04	45	40							0.62								
EK 06	60	60	0.7	10				0.62	0.7	1.0	5.0	0.1					
EK 09	90	90							0.81								
EK 13	35	30	1.5	40				0.55	2.0	5.0	50	0.2					
EK 14	45	40							0.62								
EK 16	60	60	0.7	25				0.62	1.5	1.0	10	0.1					
EK 19	90	90							0.81								
RK 13	35	30	1.7	60				0.55	2.0	5.0	50	0.2					
RK 14	45	40							0.62								
RK 16	60	60	1.5	25				0.62	1.5	1.0	15	0.1					
RK 19	90	90							0.81								
RK 33	35	30	2.5	50				0.55	2.5	5.0	50						
RK 34	45	40							0.62								
RK 36	60	60	2.0	40				0.62	2.0	2.0	20						
RK 39	90	90							0.81								
RK 43	35	30	3.0	80				0.55	3.0	5.0	50						
RK 44	45	40							0.62								
RK 46	60	60	3.5	70				0.62	3.5	3.0	35						
RK 49	90	90							0.81								
FMB-G14L	45	40	5.0	60	18	-40~ +125		0.55	5.0	5.0	100						
FMB-G24H	45	40	10	150	112.5				10	10	65						
FMB-23	35	30	4.0	50				0.62	2.0	5.0	35						
FMB-24	45	40															
FMB-26	60	60	0.7	50	12.5			0.81	3.0	3.0	15						
FMB-29	90	90							50								
FMB-24M	45	40	6.0	60	18			0.55	3.0	5.0	35	0.1					
FMB-24H	40	40	15	100	50				7.5	7.5	50						
FMB-23L	35	30	10	60				0.55	5.0	5.0	35						
FMB-24L	48	40															
FMB-26L	60	60	8.0	60	18			0.58	4.0	2.5	50						
FMB-29L	90	90							60								
FMB-33S	35	30	12	75				0.58	6.0	5.0	35						
FMB-34S	48	40															
FMB-33	35	30	15	150				0.55	7.5	10	65						
FMB-34	48	40															
FMB-36	60	60	0.7	100	50			0.62	7.5	5.0	75						
FMB-39	90	90							100								
FMB-33M	35	30	30	300				0.55	15	20	100						
FMB-34M	48	40															
FMB-36M	60	60	20	150	112.5			0.62	10	10	150						
FMB-39M	90	90							150								
CTB-24	45	40	4.0	60				0.55	2.0	5	50						
CTB-24L	48	40	10	60					5.0								
CTB-33S	35	30	12	75				0.58	6.0	5	40						
CTB-34S	48	40															
CTB-33	35	30	15	150				0.55	10	10	80						
CTB-34	48	40															
CTB-33M	35	30	30	300				0.55	15	20	100						
CTB-34M	48	40															
RBA-406B	60	60	4.0	40				0.62	2.0	2.0	20		100/100	5.0	85	4.25	

For Pulse Rectification

Available

Surface Mount

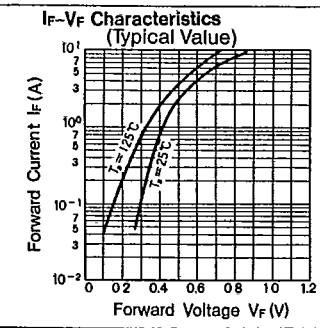
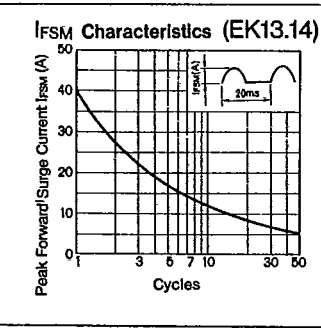
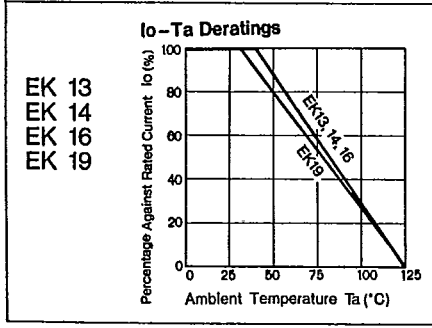
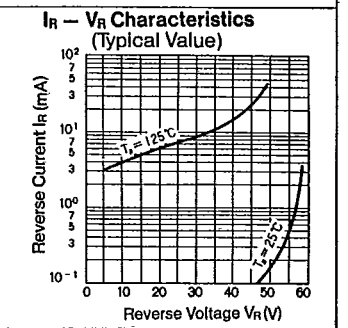
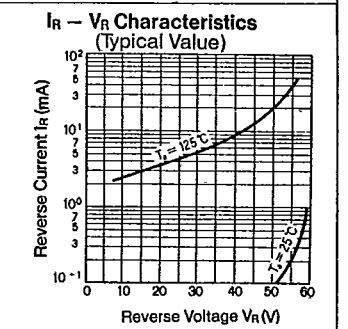
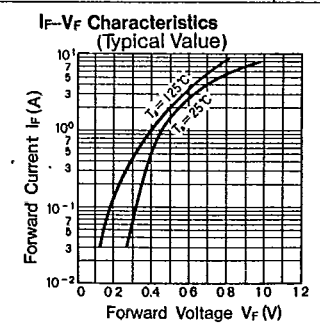
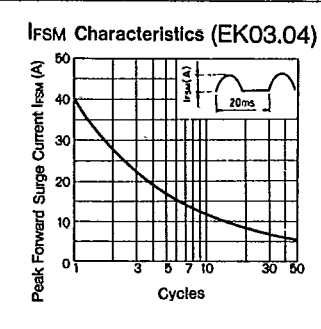
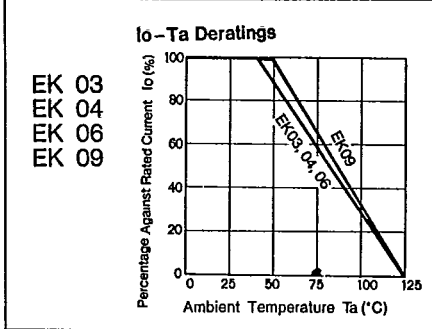
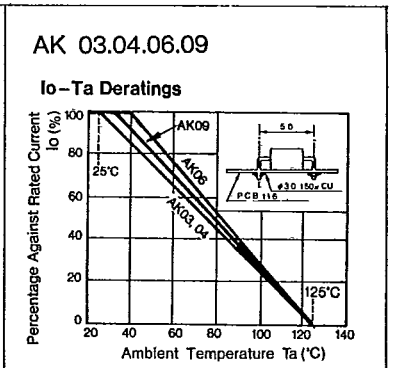
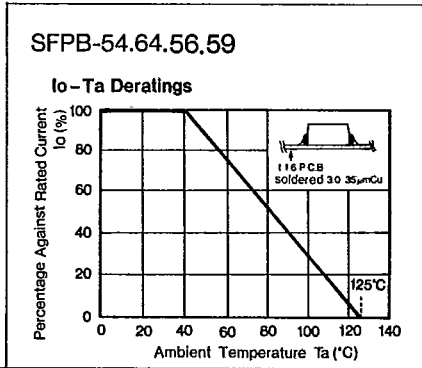
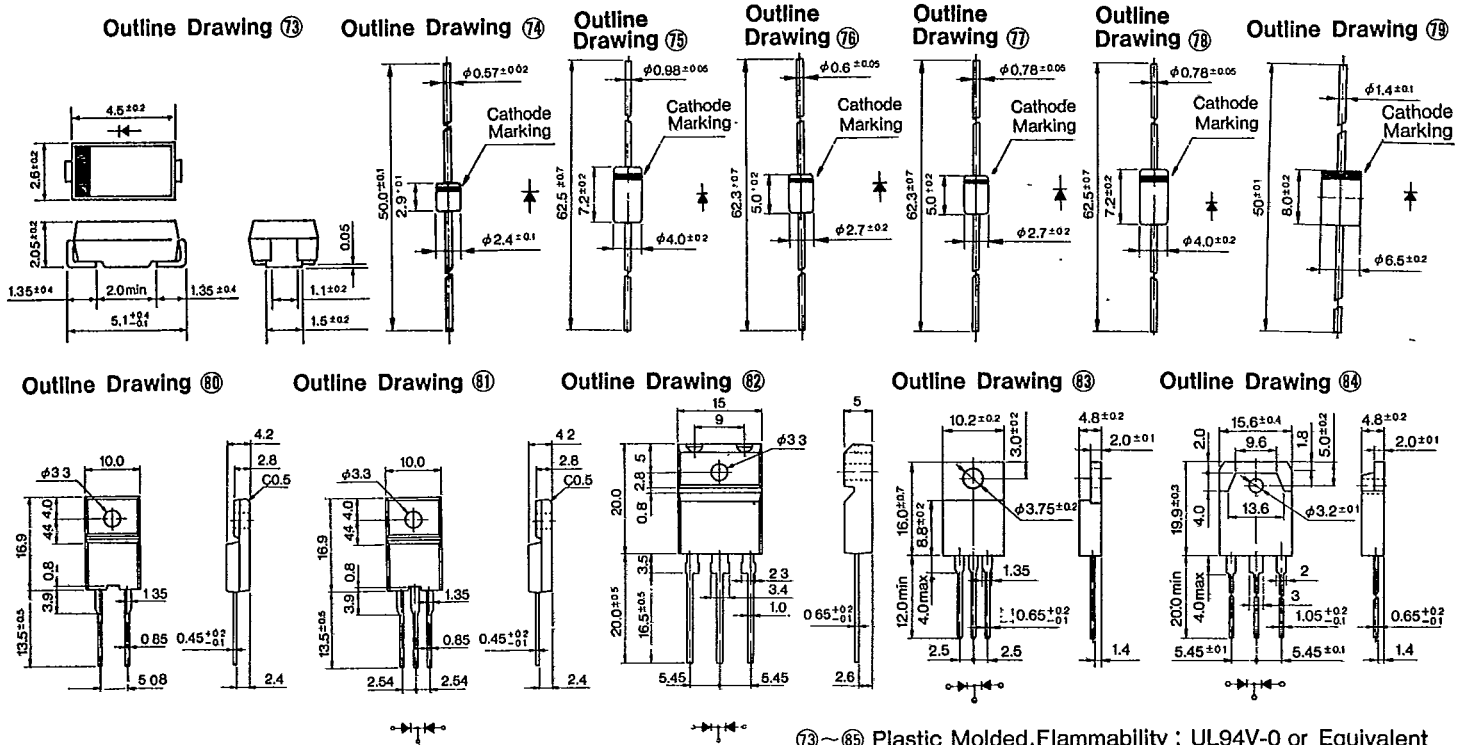

Schottky Barrier Diodes

T-23-01

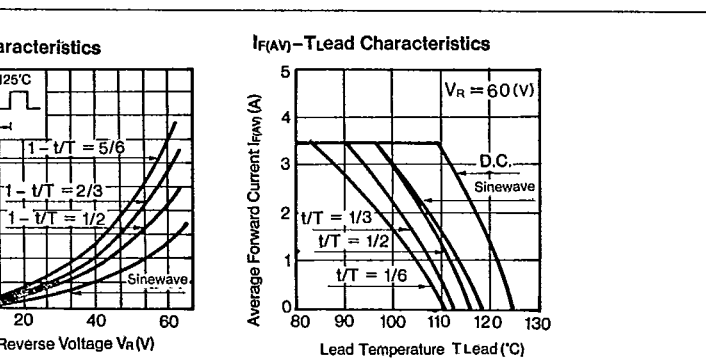
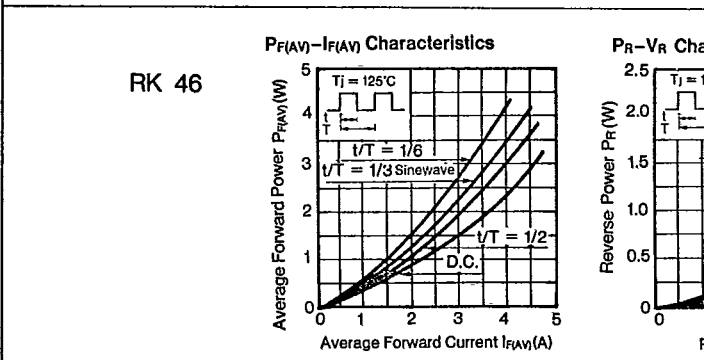
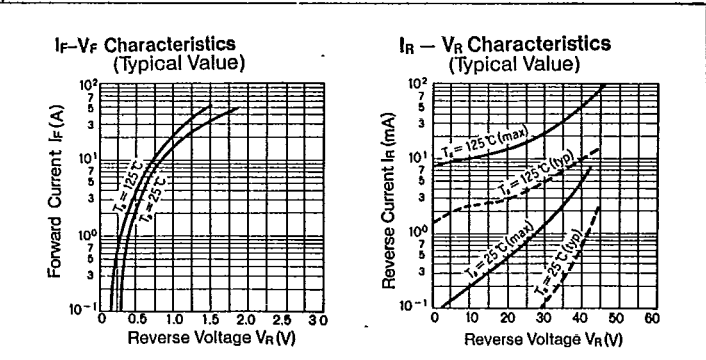
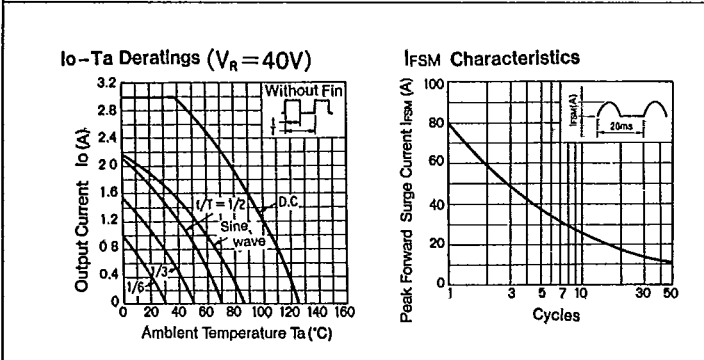
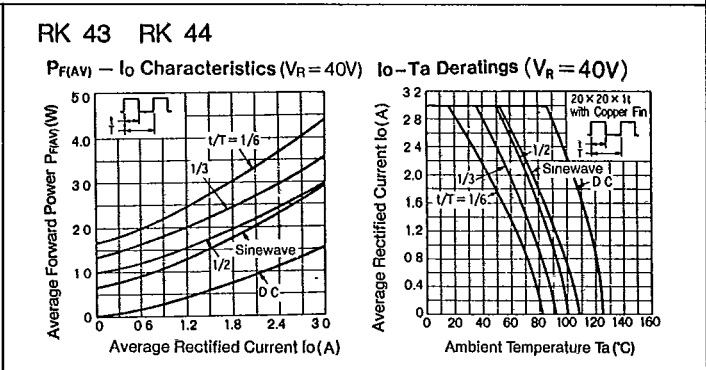
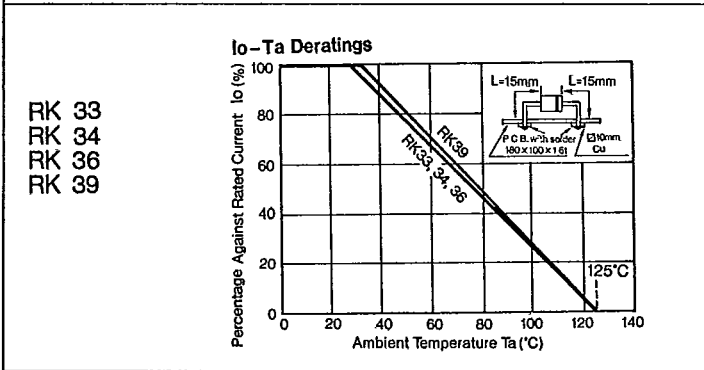
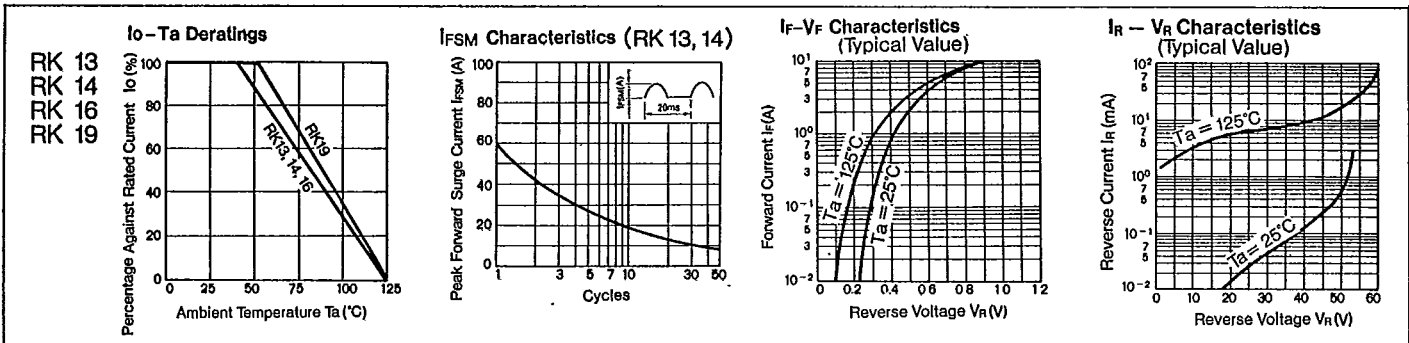

FMB-G14L

$P_{F(AV)}-I_{F(AV)}$ Characteristics

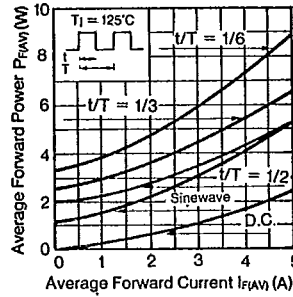

$I_{F(AV)}-T_c$ Characteristics

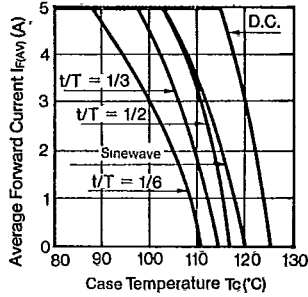

FMB-G24H

$P_{F(AV)}-I_{F(AV)}$ Characteristics

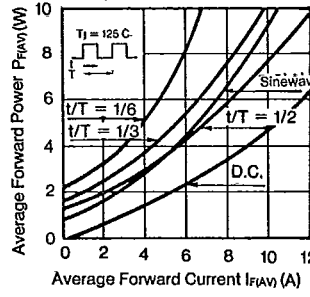

$I_{F(AV)}-T_c$ Characteristics

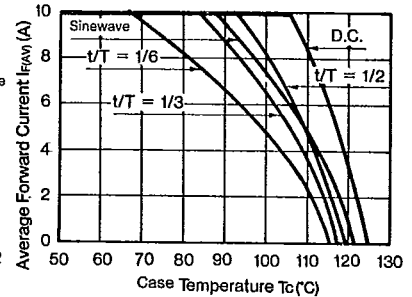

**FMB-23
FMB-24**

$P_{F(AV)}-I_{F(AV)}$ Characteristics

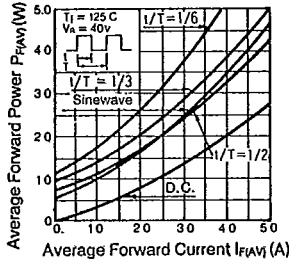

$I_{F(AV)}-T_{Lead}$ Characteristics

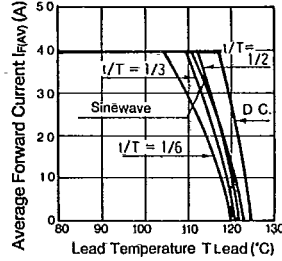

FMB-26

$P_{F(AV)}-I_{F(AV)}$ Characteristics

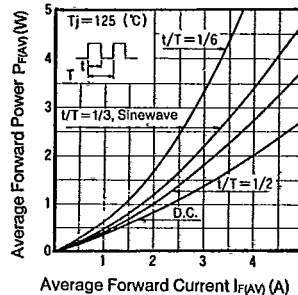

P_R-V_R Characteristics

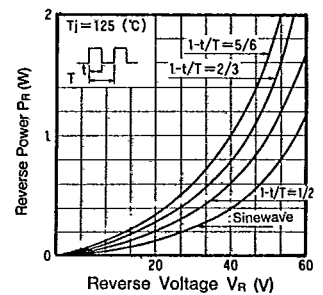

FMB-29

$P_{F(AV)}-I_{F(AV)}$ Characteristics

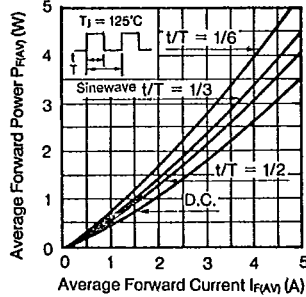

P_R-V_R Characteristics

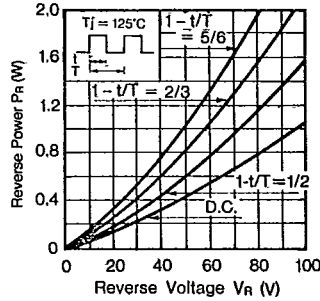

$I_{F(AV)}-T_{Lead}$ Characteristics

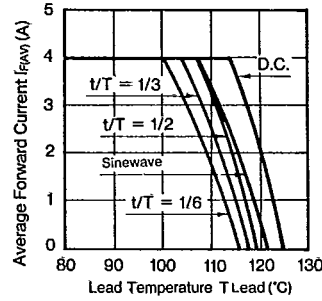

FMB-24M

$P_{F(AV)}-I_{F(AV)}$ Characteristics

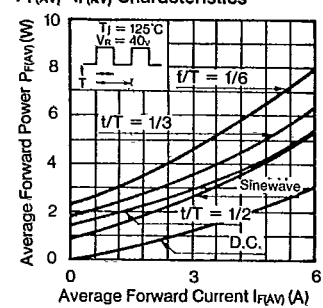

FMB-24H

$P_{F(AV)}-I_{F(AV)}$ Characteristics

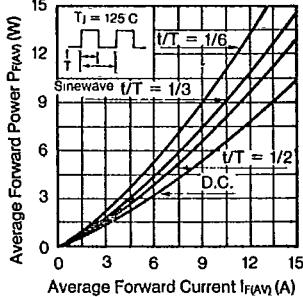

P_R-V_R Characteristics

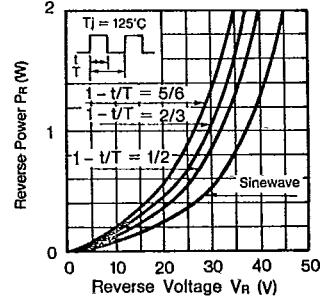

$I_{F(AV)}-T_c$ Deratings

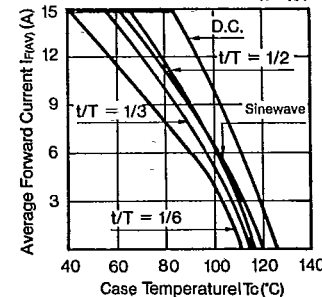

$I_{F(AV)}-T_{Lead}$ Characteristics

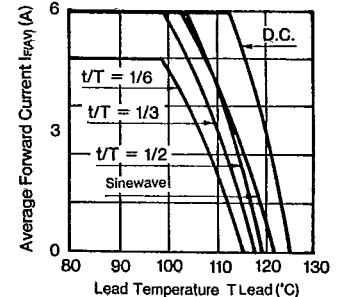

**FMB-23L
FMB-24L**

$P_{F(AV)}-I_{F(AV)}$ Characteristics

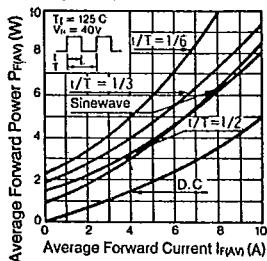

$I_{F(AV)}-T_{Lead}$ Characteristics

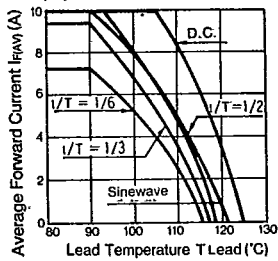

FMB-26L

$P_{F(AV)}-I_{F(AV)}$ Characteristics

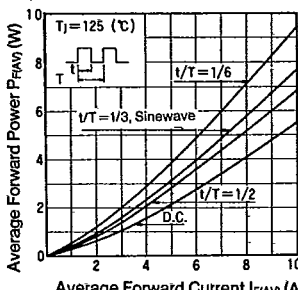

P_R-V_R Characteristics

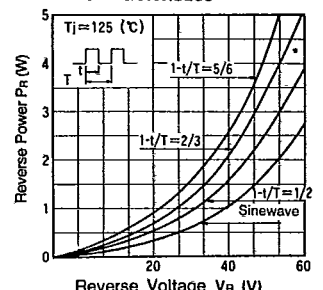

Schottky Barrier Diodes

T-23-01

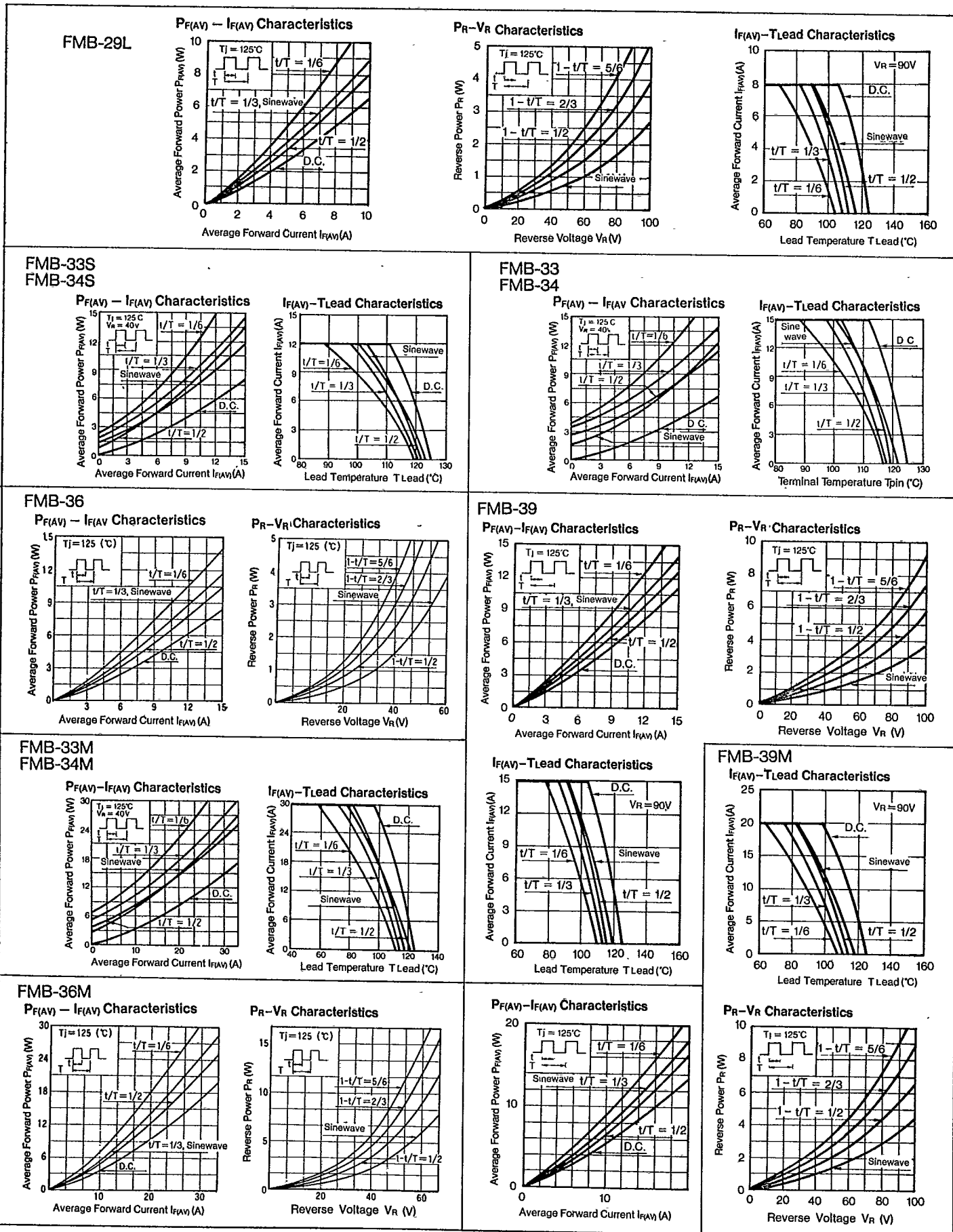

Characteristics
T-23-01

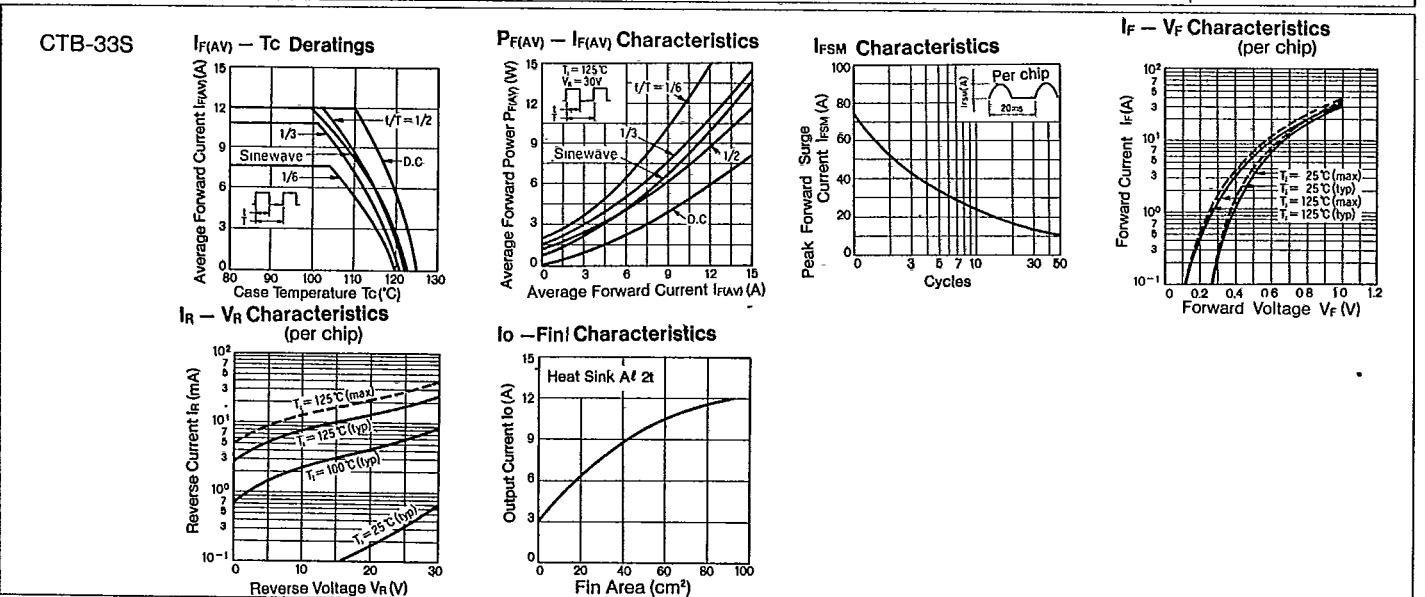
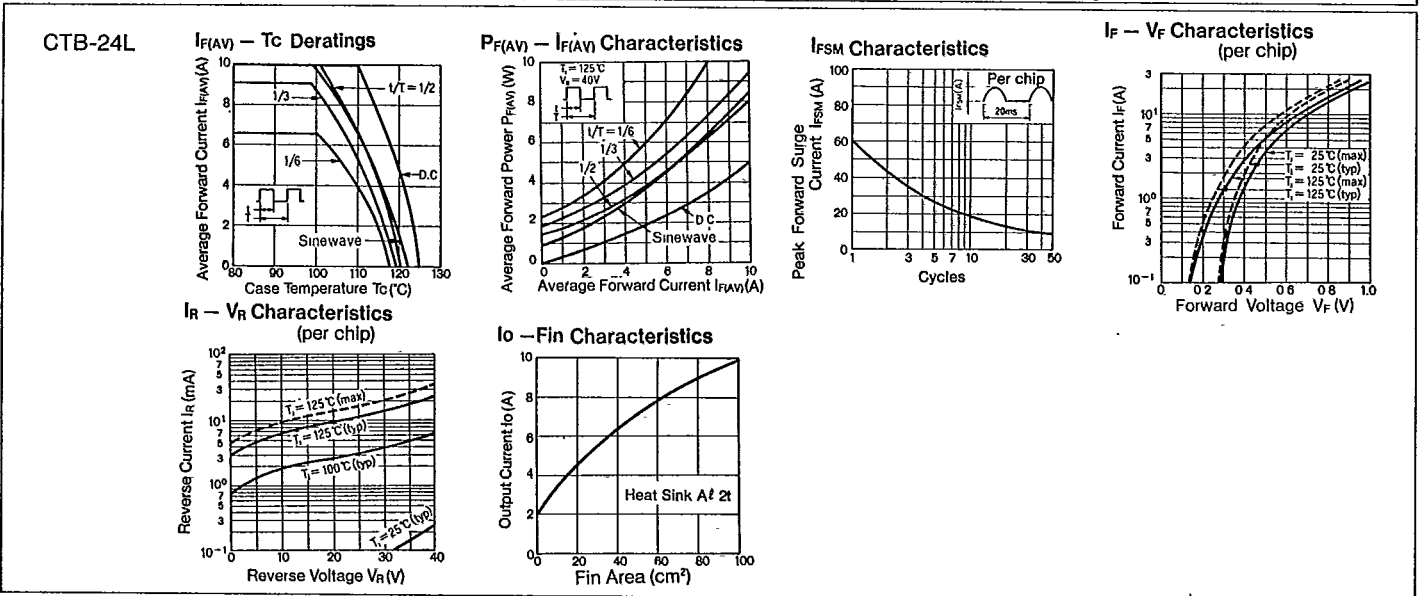
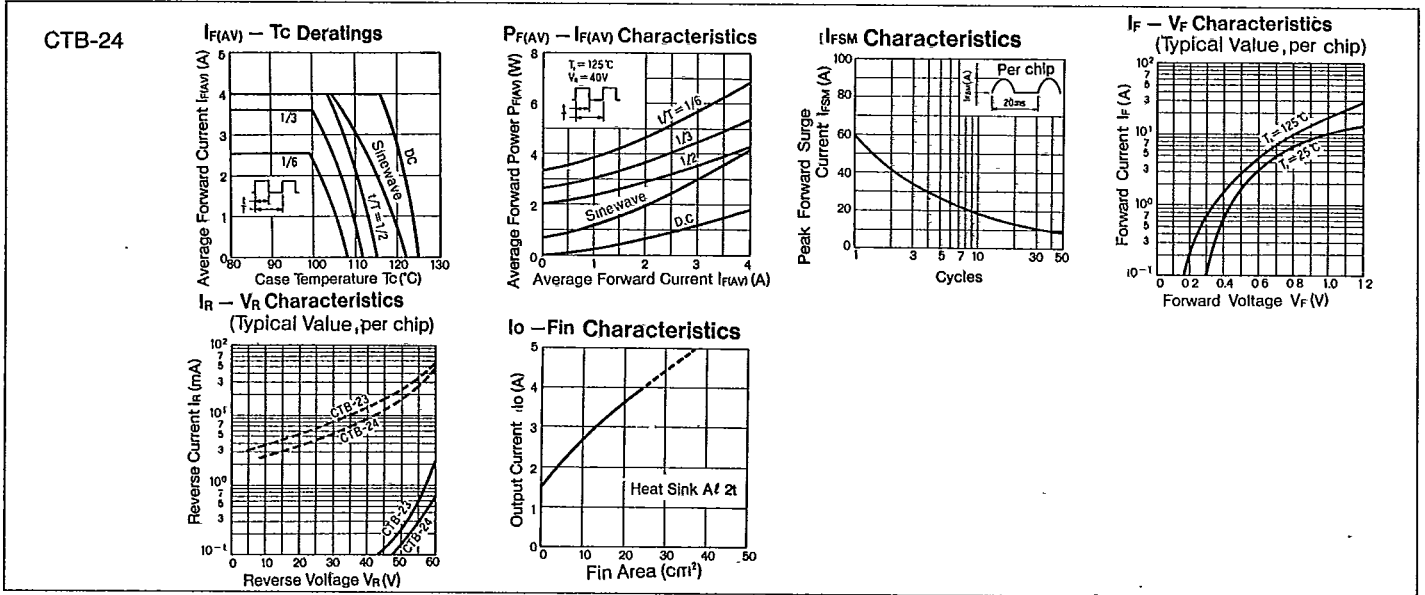



Schottky Barrier Diodes

T-23-01

CTB-34S

$I_{F(AV)} - T_c$ Deratings

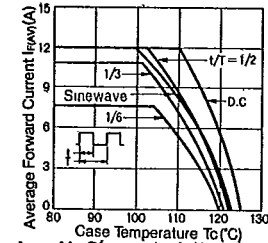

$I_R - V_R$ Characteristics (per chip)

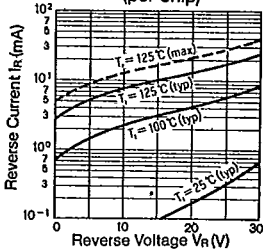

$P_{F(AV)} - I_{F(AV)}$ Characteristics

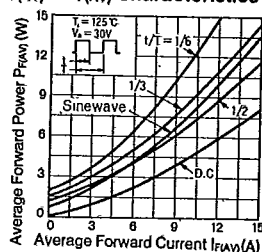

$I_o - A_{fin}$ Characteristics

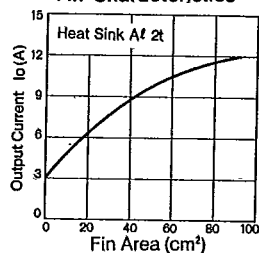

I_{FSM} Characteristics

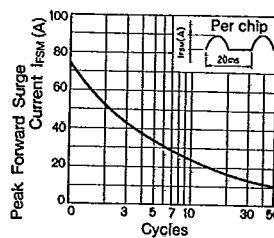

$I_F - V_F$ Characteristics (per chip)

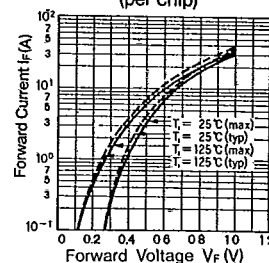

CTB-33 Series

$I_{F(AV)} - T_c$ Deratings

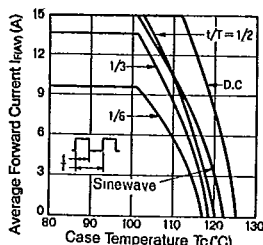

$I_R - V_R$ Characteristics (per chip)

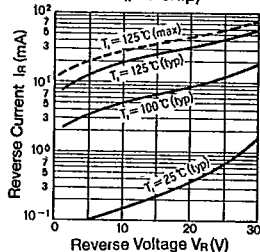

$P_{F(AV)} - I_{F(AV)}$ Characteristics

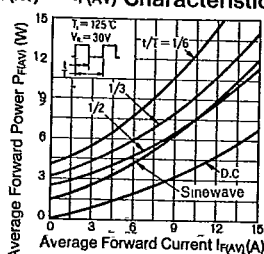

$I_o - A_{fin}$ Characteristics

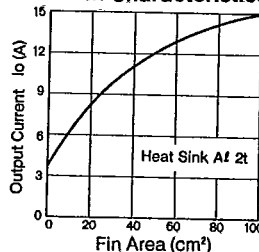

I_{FSM} Characteristics

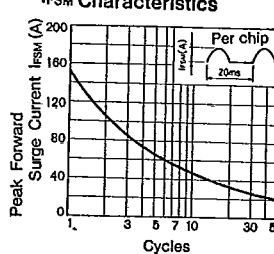

$I_F - V_F$ Characteristics (per chip)

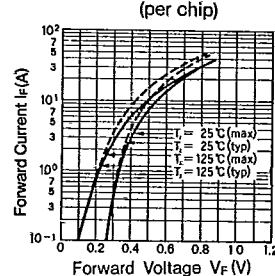

CTB-34

$I_{F(AV)} - T_c$ Deratings

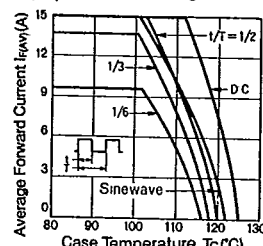

$I_R - V_R$ Characteristics (per chip)

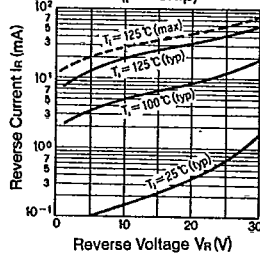

$P_{F(AV)} - I_{F(AV)}$ Characteristics

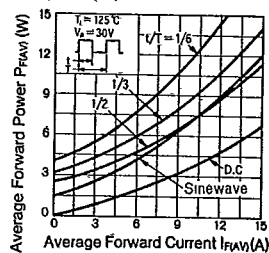

$I_o - A_{fin}$ Characteristics

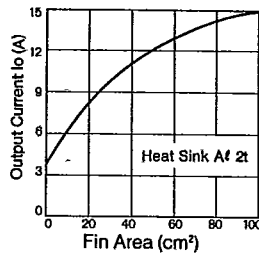

I_{FSM} Characteristics

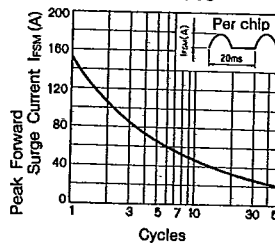

$I_F - V_F$ Characteristics (per chip)

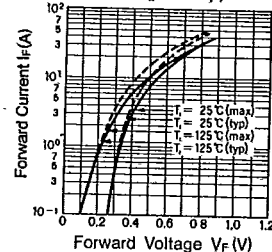

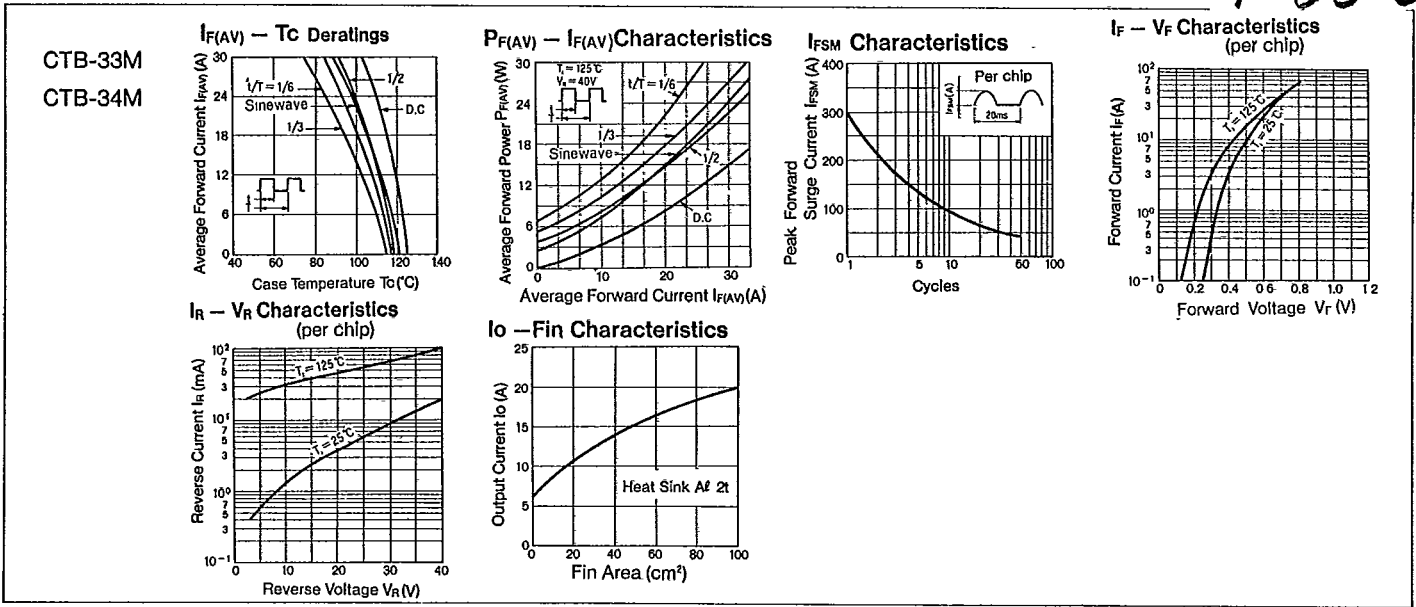

Avalanche Diodes $V_{RM}: 40 \sim 400V$ $I_{ZSM}: 0.1 \sim 3.0A$

RM/R/R Y

Rating/ Characteristics	Absolute Maximum Ratings				Electrical Characteristics (Ta = 25°C)						Others			
	V _{RM} (V)	I _{ZSM} (A)	T _J (°C)	T _{stg} (°C)	V _Z (V)	I _R (μA)	I _{RMH} (μA)	J (V/°C)	γ _Z (%/°C)	R _Z (Ω)	Outline Drawing	Weight(g)	Taping	Application
Type No.		Square Wave Single Pulse			I _Z = 1mA Instantaneous	V _R = V _{RM}	V _R = V _{RM}	I _Z = 1mA	I _Z = 1mA	I _Z = 0.5 ~ 1.5A	Ⓜ	0.44	Available	For Surge Absorption
RM 25	40	3.0	-40 ~ +130		50 ~ 61.5	5.0	20 (Ta = 80°C)	-	0.09typ.	5 max				
RM 26	50				60 ~ 70									
R 2M	130	1.0(100μs)	-40 ~ +150		135 ~ 180	10	50(Ta = 100°C)	+0.15typ.	-	-				
RY 23	200	0.1(100μs)	-40 ~ +130		250 ~ 400		50				(Ta = 80°C)			
RY 24	400				400 ~ 450									

Outline Drawing Ⓜ

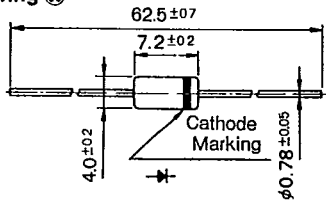

Ⓜ Plastic Molding, Flammability: UL94V-0 or Equivalent

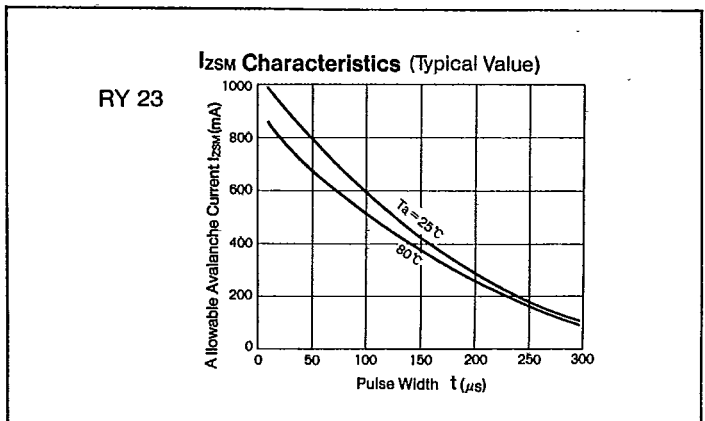
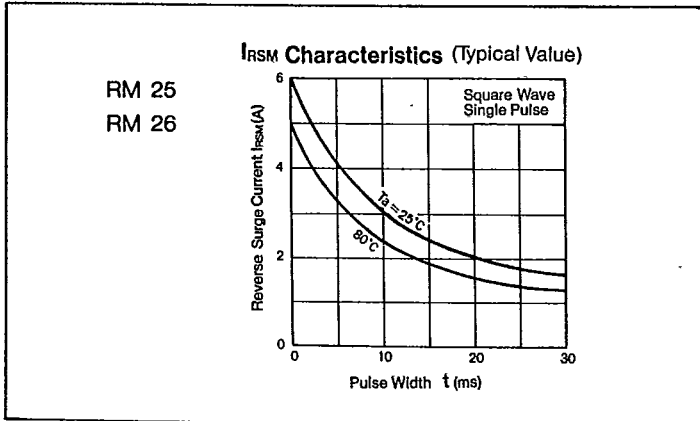

Symbols/trr Measurement Circuit

Symbols

V_{RSM}	Peak Reverse Surge Voltage	I_{RSM}	Peak Reverse Surge Current	T_{stg}	Storage Temperature
V_{RM}	Peak Reverse Voltage	I_R	Reverse Current	t_{rr}	Reverse Recovery Time
V_{P-P}	Reverse Voltage (Peak to Peak)	I_{RP}	Peak Reverse Current	C_t	Total Capacitance Between Terminals
V_R	Reverse Voltage	$I_{R(H)}$	Reverse Current (High Temperature)	$R_{th(j-c)}$	Thermal Resistance, Junction to Case
V_F	Forward Voltage	I_Z	Avalanche Current	r_Z	Temperature Coefficient of Breakdown Voltage
V_B	Breakdown Voltage	I_{ZSM}	Allowable Avalanche Current	R_Z	Equivalent Resistance of Breakdown Region
I_o	Average Rectified Forward Current	T_a	Ambient Temperature	$P_{F(AV)}$	Average Forward Power Dissipation
I_F	Forward Current	T_j	Junction Temperature	I^2_t	I^2_t limiting Value
$I_{F(AV)}$	Average Forward Current	T_{opr}	Operating Ambient Temperature		
I_{FSM}	Peak Forward Surge Current	T_c	Case Temperature		

Reverse Recovery Time Measurement Circuit

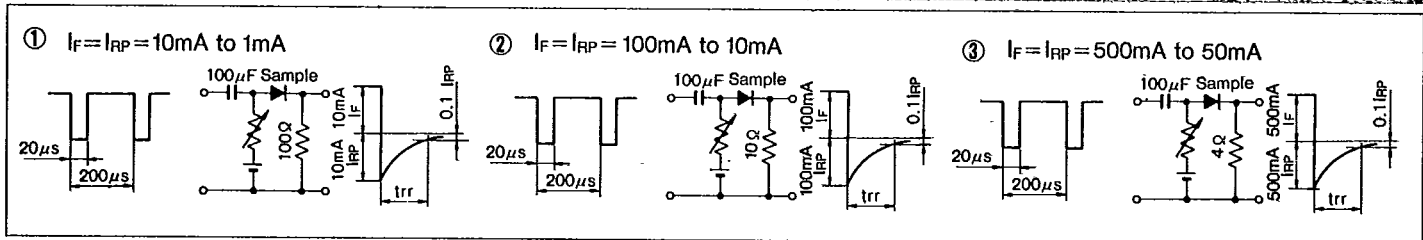

Taping Specifications

Excluding High Voltage Diodes

Designation	Dimension (in mm)	Packaging Dimension and Marking	Quantity
V Add Suffix [V] to Type No.	<p>Tape Carrier Method</p> <p>(1) Right side of taping direction is cathode. (2) Place electrode side down when casing. (3) Provide leader tape of 150~200mm at beginning of tape. (4) Provide space of more than 10 pitches each for beginning and end of tape.</p>	<p>Reel</p> <p>Marking of Type No., Lot No. and Quantity</p>	1,800 pcs per reel
V Add Suffix [V] to type No.	<p>Axial Taping</p>	<p>Reel</p> <p>Markings of Type No. Lot No. and Quantity</p>	5,000 pcs per reel (2.7φ body) 3,000 pcs per reel (4.0φ body)

Taping Specifications

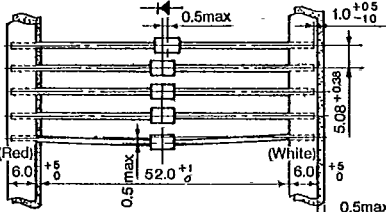
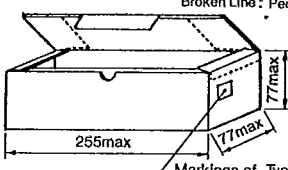
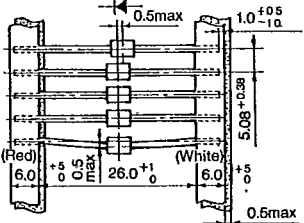
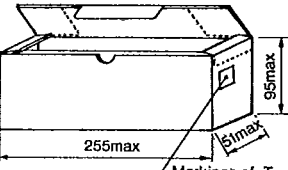
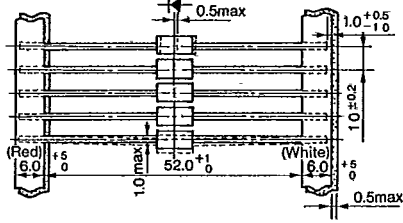
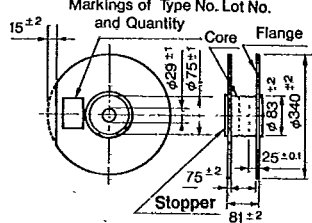
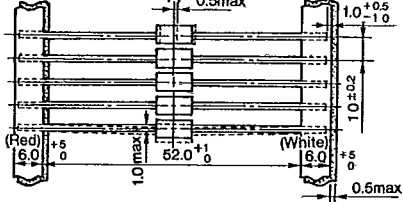
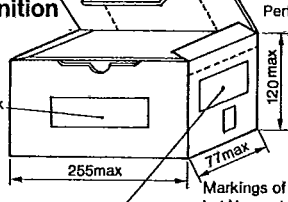
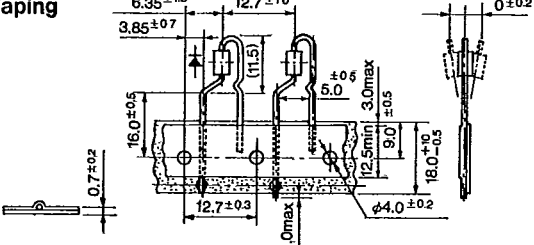
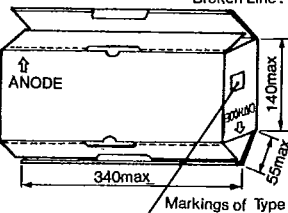
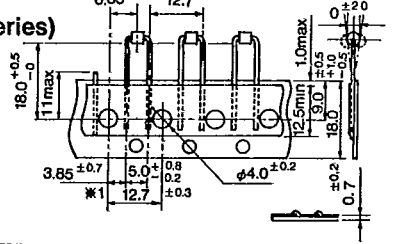
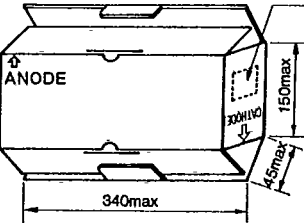
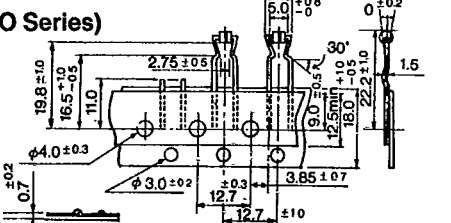
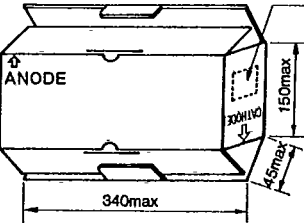
Designation	Dimension (in mm)	Packaging Dimension and Marking	Quantity
<p>V1</p> <p>Add Suffix [V1] to Type No.</p>	<p>Axial Taping</p> 	<p>Ammunition Pack</p> <p>Broken Line: Perforation</p>  <p>Markings of Type No, Lot No, and Quantity</p>	<p>2,000 pcs per box (2.7 φ body)</p> <p>1,000 pcs per box (4.0 φ body)</p>
<p>VO</p> <p>Add Suffix [VO] to Type No.</p>	<p>Axial Taping</p> 	<p>Ammunition Pack</p> <p>Broken Line: Perforation</p>  <p>Markings of Type No, Lot No, and Quantity</p>	<p>2,000 pcs per box (2.7 φ body)</p> <p>(2.4 φ body)</p>
<p>V3</p> <p>Add Suffix [V3] to Type No.</p>	<p>Axial Taping</p> 	<p>Reel</p> <p>Markings of Type No, Lot No, and Quantity</p> 	<p>1,500 pcs per reel (5.2 φ body)</p>
<p>V4</p> <p>Add Suffix [V4] to Type No.</p>	<p>Axial Taping</p> 	<p>Ammunition Pack</p> <p>Broken Line: Perforation</p> <p>Trade Mark</p>  <p>Markings of Type No, Lot No, and Quantity</p>	<p>1,000 pcs per box (5.2 φ body)</p>
<p>W</p> <p>Add Suffix [W] to Type No.</p>	<p>Radial Taping</p> 	<p>Ammunition Pack</p> <p>Broken Line: Perforation</p> <p>ANODE</p>  <p>Markings of Type No, Lot No, and Quantity</p>	<p>4,000 pcs per box (2.7 φ body)</p> <p>(0.6 φ lead)</p>
<p>WS</p> <p>Add Suffix [WS] to Type No.</p>	<p>Radial Taping (Applicable to AO Series)</p> 	<p>Ammunition Pack</p> <p>Markings of Type No, Lot No, and Quantity</p> 	<p>2,500 pcs per box (2.4 φ body)</p>
<p>WK</p> <p>Add Suffix [WK] to Type No.</p>	<p>Radial Taping (Applicable to AO Series)</p> 	<p>Ammunition Pack</p> <p>ANODE</p> 	<p>2,500 pcs per box (2.4 φ body)</p>

Marking Guide

1 Small TMD

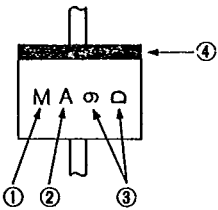

- ① Type Designation (in abbreviation)
AM01 is abbreviated as M.
- ② Class Designation
Z: 200V, No Letter: 400V, A: 600V
- ③ A: Year (Last Number of AD Year)
B: Month (Jan. to Sept. are represented by numbers 1 to 9 respectively, and Oct., Nov., and Dec. are abbreviated as O, N and D respectively)
- ④ Cathode Band: Successive Band, however AU02 Type is Non-Successive Band.

2 E/EO Type TMD

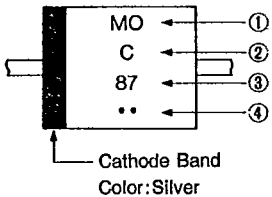

- ① Type Designation (in abbreviation)
EM01 is abbreviated as MO, EM2 is abbreviated as M2.
- ② Class Designation
Z: 200V, No Letter: 400V, A: 600V
B: 800 V, C: 1000V, F: 1500V
However, EU02A to be marked 2A, and EU2YX to be marked Y.
- ③ Abbreviations Representing Production Period
A: Year (Last Number of AD Year)
B: Month (1~9, O, N, D)
- ④ Production Period Divided in 3 ten day terms
• : 1st 10days •• : 2nd 10days ••• : 3rd 10days

3 R Type TMD

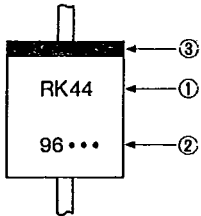

- ① Type Designation: Mark in 2 sets
- ② Production Period: Mark in 4 sets
A: Year (Last Number of AD Year)
B: Month (1~9, O, N, D)
- ③ Production Period Divided in 3 ten day terms
• : 1st 10days •• : 2nd 10days ••• : 3rd 10days
- ④ Cathode Band Color: Silver: For Power Supply
Yellow: For Middle Speed
Red : For High Speed and Ultra-High Speed

4 RB40/60

(RB40 Series)

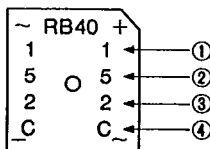

- ① Peak Reverse Voltage Designation
1, 2, 4, 6, C
Production Period
- ② Year (Last Number of AD Year)
- ③ Month (1~9, O, N, D)
- ④ Divided in 3 ten day terms
A: 1st 10days, B: 2nd 10days
C: 3rd 10days
Color Designation: Silver

(RB60 Series)

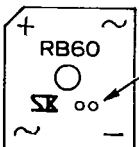

Dot Designation RB601 Violet
RB602 No Color
RB604 Blue
RB606 White

5 RBV/RBA

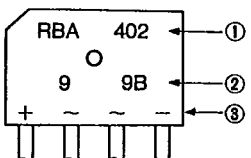

- ① Type Designation
- ② Lot Number
1st : Year (Last Number of AD Year)
2nd: Month (1~9, O, N, D)
3rd : Divided 1~3 ten day Terms
A: 1st 10 days B: 2nd 10 days
C: 3rd 10 days
- ③ In-Put Designation

6 TO220 Type (FM or CT Type)

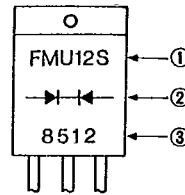

- ① Type Designation
Show FMU-12S as FMU12S.
- ② Polarity: Rectifier Symbols
- ③ Lot Number (Laser Marking)
1st : Year (Last Number of AD Year)
2nd : Month (0~9, O, N, D)
3rd, 4th: Day

7 TO220 Type (FM or CT Type, single chip)

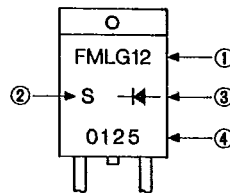

- ① Type Designation: Omit Last Letter
Show FML-G12S as FMLG12.
- ② Last Letter of Type Designation
- ③ Polarity: Rectifier Symbols
- ④ Lot Number (Laser Marking)
1st : Year (Last Number of AD Year)
2nd : Month (0~9, O, N, D)
3rd, 4th: Day

8 TO3P Type (FM or CT Type)

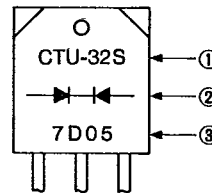

- ① Type shown in full designation
However, CTB-34/34S/34M are marked as CTB-34, CTU-G3DR is marked as CTUG3DR.
- ② Polarity: Rectifier Symbols
- ③ Lot Number:
1) M, U, G and L Types
First Number : Last Digit of AD Year
Second Number : Month
Third and Fourth Numbers: Day
Fifth Number : None
2) For types CTB-34/34S/34M, the fifth letter shows type designation. If no fifth number, the type is CTB-33 or CTB-34.
- 3) Marking Color: Silver

9 MI-10/15 Type

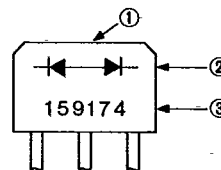

- ① MI-10/15 is die-stamped on the top of the case.
- ② Rectifier Symbols
- ③ Lot Number:
First Number : Peak Reverse Voltage:
(Letter) 0=50V, 1=100V, 2=200V,
4=400V, 6=600V, C=1000V
Second Number : Last Digit of AD Year
Third Number : Month
Fourth and Fifth Numbers: Day
Sixth Number : Production number and
U: Voltage Doubler Type

10 SFP Type

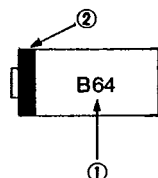

- ① Type Designation:
SFPB-64 is abbreviated at B64,
- ② Cathode Band