

TC4516BP/TC4516BF PRESETTABLE BINARY UP/DOWN COUNTER

TC4516BP/BF is UP/DOWN 4 bit binary counter having asynchronous and PRESET functions.

When RESET input is set to "H" level, the content of counter is reset to "0" and when RESET is set to "L" and P.E. to "H", inputs A_{IN} through D_{IN} are preset into the counter.

If TC4516BP/BF's are connected in cascade using CARRY INPUT and CARRY OUTPUT, 4 × N bits binary counter with parallel counter can be composed.

Switching of counting up or down is achieved by UP/DOWN input. The counter advances its counting condition at the rising edge of CLOCK.

ABSOLUTE MAXIMUM RATINGS

CHARACTERISTIC	SYMBOL	RATING	UNIT
DC Supply Voltage	V _{DD}	V _{SS} -0.5 ~ V _{SS} +20	V
Input Voltage	V _{IN}	V _{SS} -0.5 ~ V _{DD} +0.5	V
Output Voltage	V _{OUT}	V _{SS} -0.5 ~ V _{DD} +0.5	V
DC Input Current	I _{IN}	±10	mA
Power Dissipation	P _D	300(DIP)/180(MFP)	mW
Operating Temperature Range	T _A	-40 ~ 85	°C
Storage Temperature Range	T _{stg}	-65 ~ 150	°C
Lead Temp./Time	T _{sol}	260°C · 10 sec	

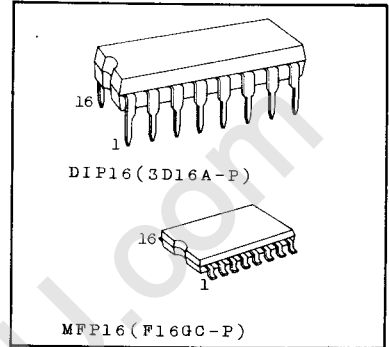

PIN ASSIGNMENT

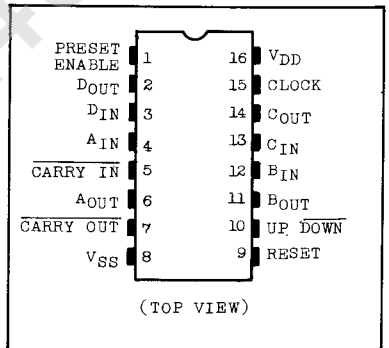

LOGIC DIAGRAM

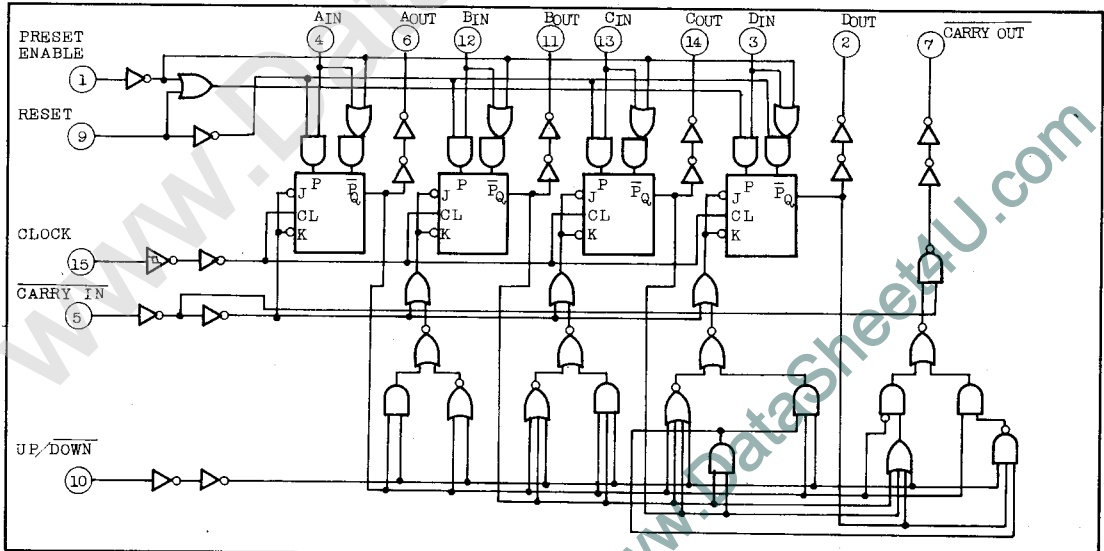

TC4516BP/BF

TRUTH TABLE

CARRY IN	UP/DOWN	PRESET ENABLE	RESET	FUNCTION
H	*	L	L	NO COUNT
L	H	L	L	UP COUNT
L	L	L	L	DOWN COUNT
*	*	H	L	PRESET
*	*	*	H	RESET

* Don't care

TIMING DIAGRAM

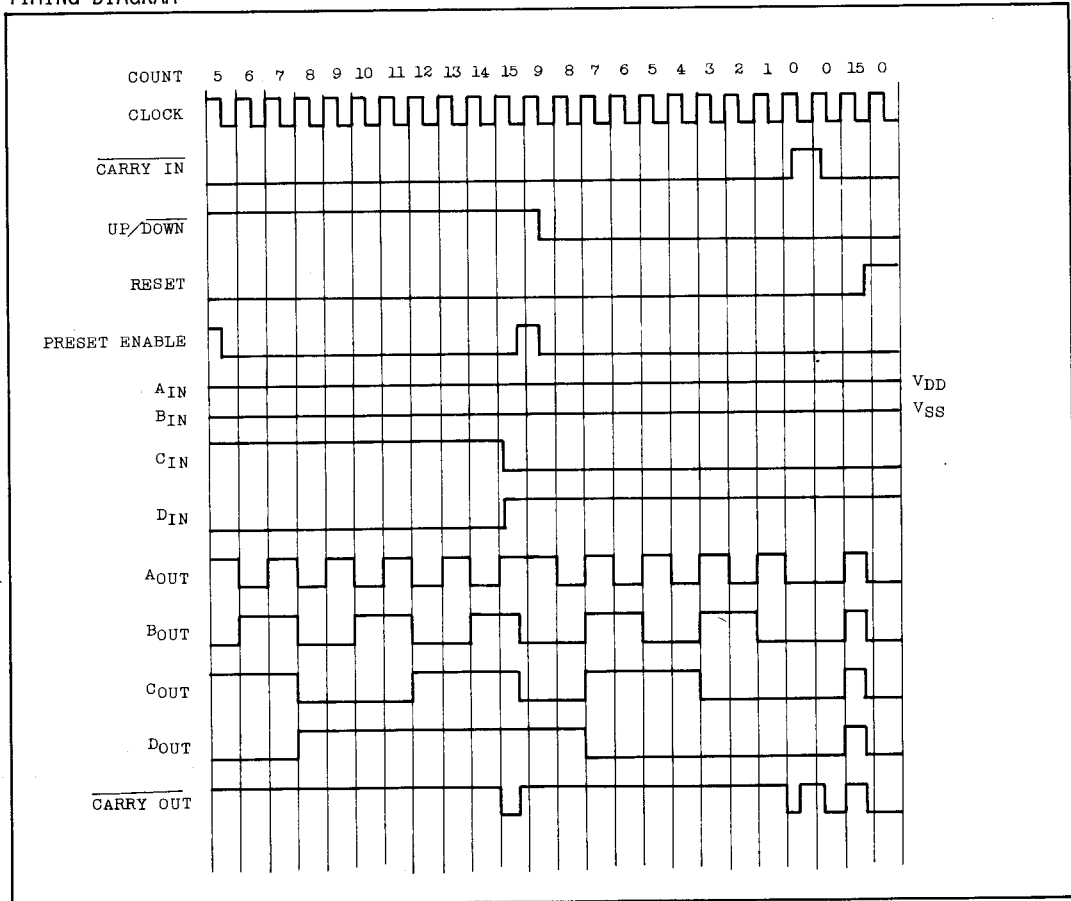

RECOMMENDED OPERATING CONDITIONS (V_{SS}=0V)

CHARACTERISTIC	SYMBOL	MIN.	TYP.	MAX.	UNIT
DC Supply Voltage	V _{DD}	3	-	18	V
Input Voltage	V _{IN}	0	-	V _{DD}	V

STATIC ELECTRICAL CHARACTERISTICS (V_{SS}=0V)

CHARACTERISTIC	SYMBOL	TEST CONDITION	V _{DD} (V)	-40°C		25°C			85°C		UNIT	
				MIN.	MAX.	MIN.	TYP.	MAX.	MIN.	MAX.		
High-Level Output Voltage	V _{OH}	I _{OUT} < 1μA V _{IN} =V _{SS} , V _{DD}	5	4.95	-	4.95	5.00	-	4.95	-	V	
			10	9.95	-	9.95	10.00	-	9.95	-		
			15	14.95	-	14.95	15.00	-	14.95	-		
Low-Level Output Voltage	V _{OL}	I _{OUT} < 1μA V _{IN} =V _{SS} , V _{DD}	5	-	0.05	-	0.00	0.05	-	0.05	V	
			10	-	0.05	-	0.00	0.05	-	0.05		
			15	-	0.05	-	0.00	0.05	-	0.05		
Output High Current	I _{OH}	V _{OH} =4.6V V _{OH} =2.5V V _{OH} =9.5V V _{OH} =13.5V V _{IN} =V _{SS} , V _{DD}	5	-0.61	-	-0.51	-1.0	-	-0.42	-	mA	
			5	-2.5	-	-2.1	-4.0	-	-1.7	-		
			10	-1.5	-	-1.3	-2.2	-	-1.1	-		
			15	-4.0	-	-3.4	-9.0	-	-2.8	-		
Output Low Current	I _{OL}	V _{OL} =0.4V V _{OL} =0.5V V _{OL} =1.5V V _{IN} =V _{SS} , V _{DD}	5	0.61	-	0.51	1.2	-	0.42	-	mA	
			10	1.5	-	1.3	3.2	-	1.1	-		
			15	4.0	-	3.4	12.0	-	2.8	-		
Input High Voltage	V _{IH}	V _{OUT} =0.5V, 4.5V V _{OUT} =1.0V, 9.0V V _{OUT} =1.5V, 13.5V I _{OUT} < 1μA	5	3.5	-	3.5	2.75	-	3.5	-	V	
			10	7.0	-	7.0	5.5	-	7.0	-		
			15	11.0	-	11.0	8.25	-	11.0	-		
Input Low Voltage	V _{IL}	V _{OUT} =0.5V, 4.5V V _{OUT} =1.0V, 9.0V V _{OUT} =1.5V, 13.5V I _{OUT} < 1μA	5	-	1.5	-	2.25	1.5	-	1.5	V	
			10	-	3.0	-	4.5	3.0	-	3.0		
			15	-	4.0	-	6.75	4.0	-	4.0		
Input Current	"H" Level	I _{IH}	V _{IH} =18V	18	-	0.1	-	10 ⁻⁵	0.1	-	1.0	μA
	"L" Level	I _{IL}	V _{IL} =0V	18	-	-0.1	-	10 ⁻⁵	-0.1	-	-1.0	
Quiescent Device Current	I _{DD}	V _{IN} =V _{SS} , V _{DD} *	5	-	5	-	0.005	5	-	150	μA	
			10	-	10	-	0.010	10	-	300		
			15	-	20	-	0.015	20	-	600		

* All valid input combinations.

TC4516BP/BF

DYNAMIC ELECTRICAL CHARACTERISTICS

CHARACTERISTIC	SYMBOL	TEST CONDITION	V _{DD} (V)	MIN.	TYP.	MAX.	UNIT
Output Transition Time (Low to High)	t _{TLH}		5	-	70	200	ns
			10	-	35	100	
			15	-	30	80	
Output Transition Time (High to Low)	t _{THL}		5	-	70	200	
			10	-	35	100	
			15	-	30	80	
Propagation Delay Time (CLOCK-A, B, C, D _{OUT})	t _{pLH} t _{pHL}		5	-	180	400	
			10	-	85	200	
			15	-	60	150	
Propagation Delay Time (CLOCK-CARRY OUT)	t _{pLH} t _{pHL}		5	-	220	480	
			10	-	100	240	
			15	-	75	180	
Propagation Delay Time (PRESET ENABLE, RESET-A, B, C, D _{OUT})	t _{pLH} t _{pHL}		5	-	180	420	
			10	-	85	210	
			15	-	65	160	
Propagation Delay Time (PRESET ENABLE RESET-CARRY OUT)	t _{pLH} t _{pHL}		5	-	240	640	
			10	-	110	320	
			15	-	80	250	
Propagation Delay Time (CARRY IN - CARRY OUT)	t _{pLH} t _{pHL}		5	-	85	250	
			10	-	45	120	
			15	-	35	100	
Max. Clock Frequency	f _{CL}		5	2	5	-	MHz
			10	4	10	-	
			15	5.5	14	-	
Max. Clock Input Rise Time Max. Clock Input Fall Time	t _{rCL} t _{fCL}		5	NO Limit			μs
			10				
			15				
Min. Clock Pulse Width	t _w		5	-	40	150	ns
			10	-	20	75	
			15	-	15	60	
Min. Pulse Width (PRESET ENABLE, RESET)	t _{WH}		5	-	55	200	
			10	-	25	100	
			15	-	20	75	

DYNAMIC ELECTRICAL CHARACTERISTICS (Ta=25°C, VSS=0V, CL=50pF)

CHARACTERISTIC	SYMBOL	TEST CONDITION	VDD(V)	MIN.	TYP.	MAX.	UNIT
Min. Set-up Time (UP/DOWN-CLOCK)	t _{SU}		5	-	95	360	ns
			10	-	45	160	
			15	-	30	110	
Min. Hold Time (UP/DOWN-CLOCK)	t _H		5	-	-	30	
			10	-	-	30	
			15	-	-	30	
Min. Set-up Time (CARRY IN - CLOCK)	t _{SU}		5	-	75	150	
			10	-	35	60	
			15	-	25	45	
Min. Hold Time (CARRY IN - CLOCK)	t _H		5	-	-	60	
			10	-	-	30	
			15	-	-	30	
Min. Set-Up Time (A,B,C,D-PRESET ENABLE)	t _{SU}		5	-	35	70	
			10	-	15	30	
			15	-	10	20	
Min. Hold Time (A,B,C,D-PRESET ENABLE)	t _H		5	-	15	70	
			10	-	10	40	
			15	-	5	40	
Min. Removal Time (PRESET ENABLE, RESET-CLOCK)	t _{rem}		5	-	40	150	
			10	-	20	80	
			15	-	15	60	
Input Capacitance	C _{IN}				5	7.5	pF

WAVEFORMS FOR MEASUREMENT OF DYNAMIC CHARACTERISTICS

WAVEFORM 1

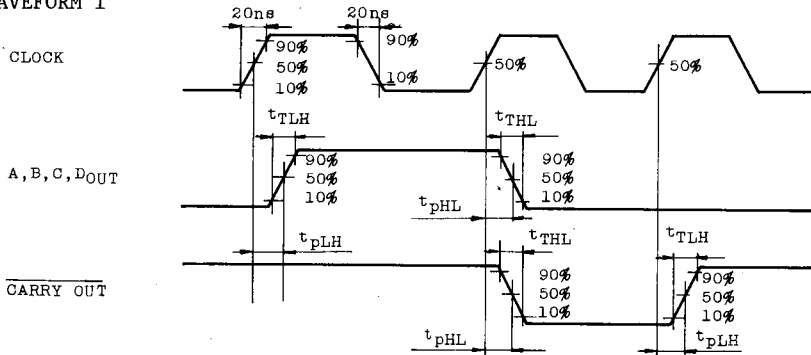

WAVEFORM 2

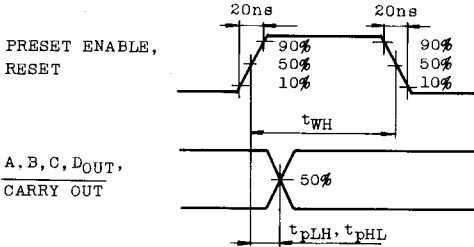

WAVEFORM 3

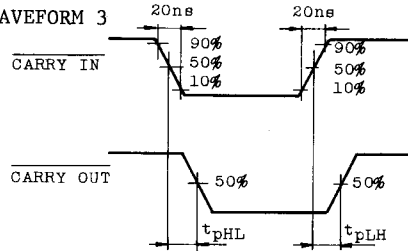

WAVEFORM 4

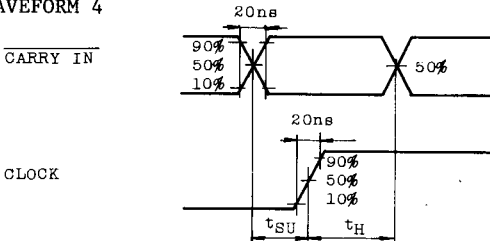

WAVEFORM 5

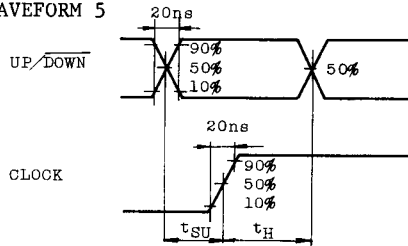

WAVEFORM 6

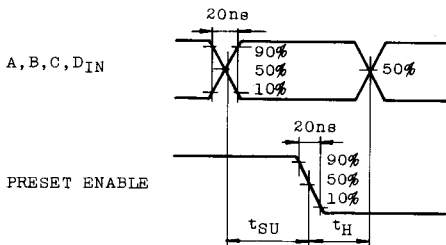

WAVEFORM 7

