

**LOW VOLTAGE (1.24V) ADJUSTABLE PRECISION SHUNT REGULATOR****AZ431L****General Description**

The AZ431L series ICs are low voltage three-terminal adjustable regulators with guaranteed thermal stability over a full operation range. These ICs feature sharp turn-on characteristics, low temperature coefficient and low output impedance, which make them ideal substitutes for Zener diodes in applications such as switching power supply, charger, motherboard and other adjustable regulators.

The output voltage can be set to any value between 1.24V and 18V with two external resistors.

The AZ431L precision reference is offered in two voltage tolerance: 0.5% and 1.0%.

These ICs are available in 4 packages: TO-92 (bulk or ammo packing), SOT-23, SOT-23-5, SOT-89-3.

Features

- Wide Programmable Precise Output Voltage from 1.24V to 18V
- High Stability under Capacitive Load
- Low Temperature Deviation: 3mV Typical
- Low Equivalent Full-range Temperature Coefficient: 20PPM/°C Typical
- Low Dynamic Output Resistance: 0.05Ω Typical
- High Sink Current Capacity from 0.1mA to 100mA
- Low Output Noise
- Wide Operating Range of -40 to 125°C

Applications

- Graphic Card
- PC Motherboard
- Voltage Adapter
- Switching Power Supply
- Charger

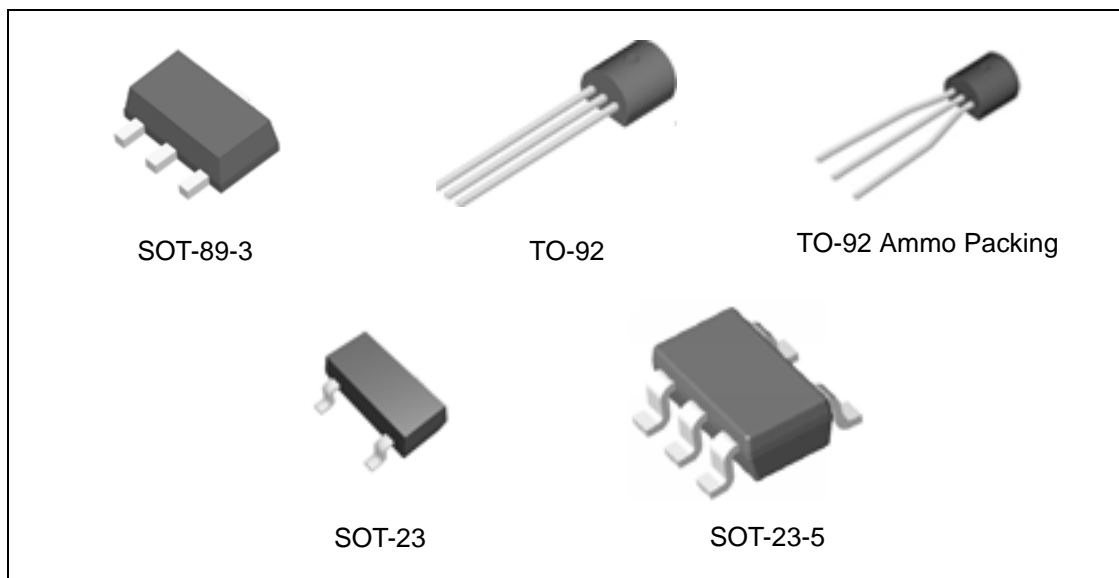

Figure 1. Package Types of AZ431L



LOW VOLTAGE (1.24V) ADJUSTABLE PRECISION SHUNT REGULATOR

AZ431L

Pin Configuration

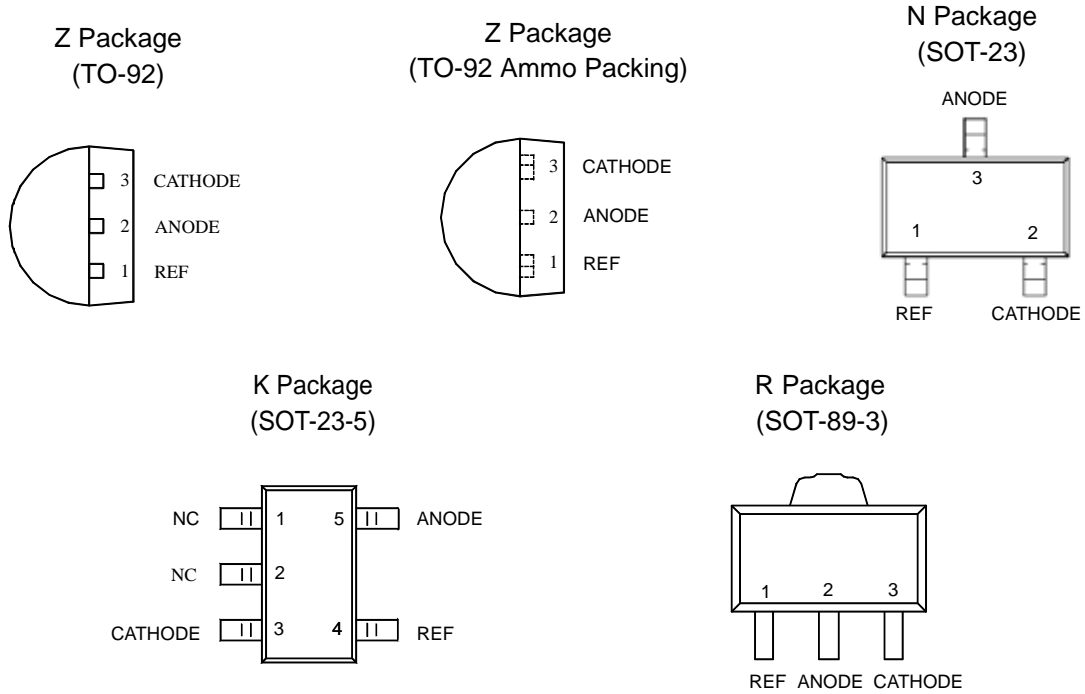

Figure 2. Pin Configuration of AZ431L (Top View)

Functional Block Diagram

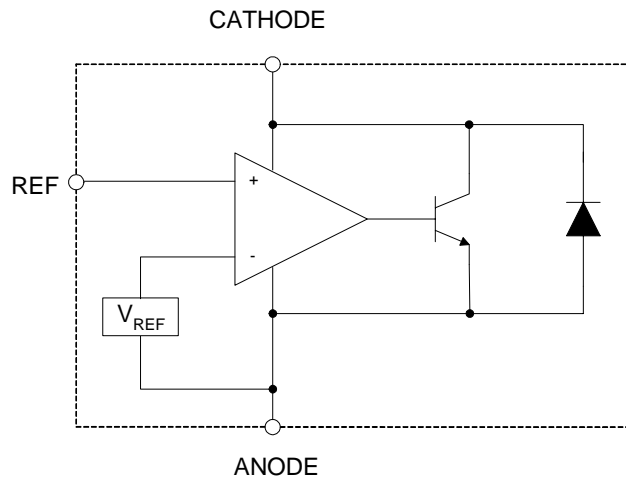

Figure 3. Functional Block Diagram of AZ431L



LOW VOLTAGE (1.24V) ADJUSTABLE PRECISION SHUNT REGULATOR

AZ431L

Ordering Information

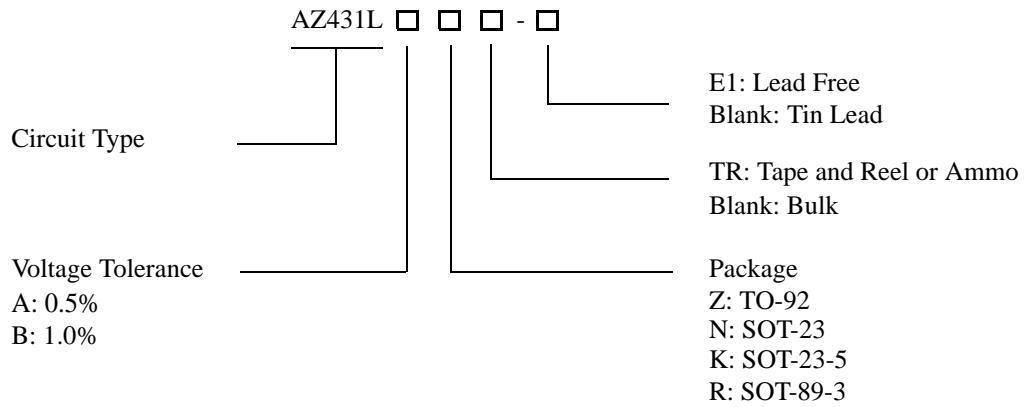

Package	Temperature Range	Voltage Tolerance	Part Number		Marking ID		Packing Type
			Tin Lead	Lead Free	Tin Lead	Lead Free	
TO-92	-40 to 125°C	0.5%	AZ431LAZ	AZ431LAZ-E1	AZ431LAZ	AZ431LAZ-E1	Bulk
		0.5%	AZ431LAZTR	AZ431LAZTR-E1	AZ431LAZ	AZ431LAZ-E1	Ammo
		1.0%	AZ431LBZ	AZ431LBZ-E1	AZ431LBZ	AZ431LBZ-E1	Bulk
		1.0%	AZ431LBZTR	AZ431LBZTR-E1	AZ431LBZ	AZ431LBZ-E1	Ammo
SOT-23	-40 to 125°C	0.5%		AZ431LANTR-E1		EA6	Tape & Reel
		1.0%		AZ431LBNTR-E1		EA7	Tape & Reel
SOT-23-5	-40 to 125°C	0.5%	AZ431LAKTR	AZ431LAKTR-E1	K41	E5A	Tape & Reel
		1.0%	AZ431LBKTR	AZ431LBKTR-E1	K42	E6A	Tape & Reel
SOT-89-3	-40 to 125°C	0.5%	AZ431LARTR	AZ431LARTR-E1	R41A	E41A	Tape & Reel
		1.0%	AZ431LBRTR	AZ431LBRTR-E1	R41B	E41B	Tape & Reel

BCD Semiconductor's Pb-free products, as designated with "E1" suffix in the part number, are RoHS compliant.

**LOW VOLTAGE (1.24V) ADJUSTABLE PRECISION SHUNT REGULATOR****AZ431L****Absolute Maximum Ratings (Note 1)**

Parameter	Symbol	Value		Unit
Cathode Voltage	V_{KA}	20		V
Cathode Current Range (Continuous)	I_{KA}	-100 to 100		mA
Reference Input Current Range	I_{REF}	10		mA
Power Dissipation	P_D	Z, R Package	770	mW
		N, K Package	370	
Junction Temperature	T_J	150		°C
Storage Temperature Range	T_{STG}	-65 to 150		°C

Note 1: Stresses greater than those listed under "Absolute Maximum Ratings" may cause permanent damage to the device. These are stress ratings only, and functional operation of the device at these or any other conditions beyond those indicated under "Recommended Operating Conditions" is not implied. Exposure to "Absolute Maximum Ratings" for extended periods may affect device reliability.

Recommended Operating Conditions

Parameter	Symbol	Min	Max	Unit
Cathode Voltage	V_{KA}	V_{REF}	18	V
Cathode Current	I_{KA}	0.1	100	mA
Operating Ambient Temperature Range		-40	125	°C



LOW VOLTAGE (1.24V) ADJUSTABLE PRECISION SHUNT REGULATOR

AZ431L

Electrical Characteristics

(Operating Conditions: $T_A=25^{\circ}\text{C}$, unless otherwise noted.)

Parameter	Test Circuit	Symbol	Conditions	Min	Typ	Max	Unit
Reference Voltage	0.5%	4	$V_{KA}=V_{REF}, I_{KA}=10\text{mA}$	1.234	1.240	1.246	V
	1.0%			1.228	1.240	1.252	
Deviation of Reference Voltage Over Full Temperature Range	4	ΔV_{REF}	$V_{KA}=V_{REF}, I_{KA}=10\text{mA}$	0°C to 70°C	2	10	mV
				-40°C to 85°C	3	10	
				-40°C to 125°C	4	15	
Ratio of Change in V_{REF} to the Change in Cathode Voltage	5	$\frac{\Delta V_{REF}}{\Delta V_{KA}}$	$I_{KA}=10\text{mA}, \Delta V_{KA}:V_{REF}$ to 16V		-0.5	-1.5	mV/V
Reference Input Current	5	I_{REF}	$I_{KA}=10\text{mA}, R1=10\text{K}\Omega, R2=\infty$		0.15	0.4	μA
Deviation of Reference Current Over Full Temperature Range	5	ΔI_{REF}	$I_{KA}=10\text{mA}, R1=10\text{K}\Omega, R2=\infty, T_A=-40$ to 125°C		0.1	0.4	μA
Minimum Cathode Current for Regulation	4	I_{KA} (Min)	$V_{KA}=V_{REF}$		55	80	μA
Off-state Cathode Current	6	I_{KA} (Off)	$V_{REF}=0, V_{KA}=18\text{V}$		0.04	0.10	μA
			$V_{KA}=6, V_{REF}=0$		0.01	0.05	
Dynamic Impedance	4	Z_{KA}	$V_{KA}=V_{REF}, I_{KA}=1$ to $100\text{mA}, f \leq 1.0\text{kHz}$		0.05	0.15	Ω



LOW VOLTAGE (1.24V) ADJUSTABLE PRECISION SHUNT REGULATOR

AZ431L

Electrical Characteristics (Continued)

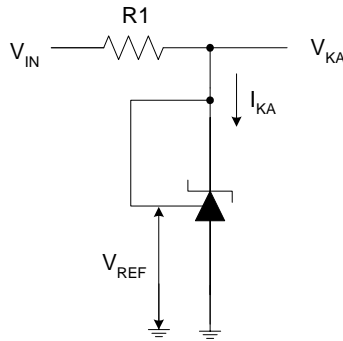

Figure 4. Test Circuit 4 for $V_{KA} = V_{REF}$

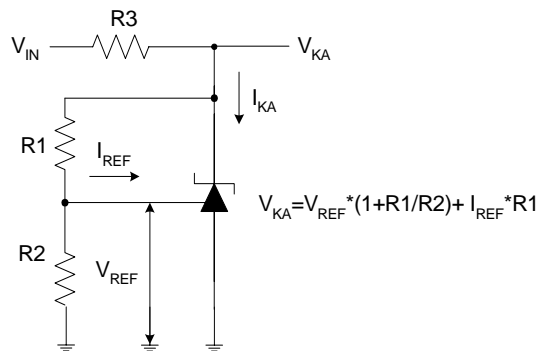

Figure 5. Test Circuit 5 for $V_{KA} > V_{REF}$

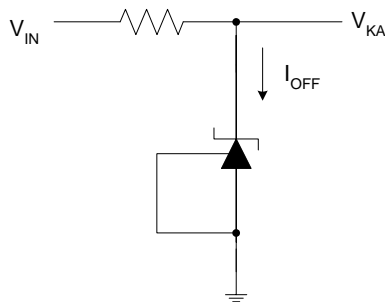

Figure 6. Test Circuit 6 for I_{OFF}



LOW VOLTAGE (1.24V) ADJUSTABLE PRECISION SHUNT REGULATOR

AZ431L

Typical Performance Characteristics

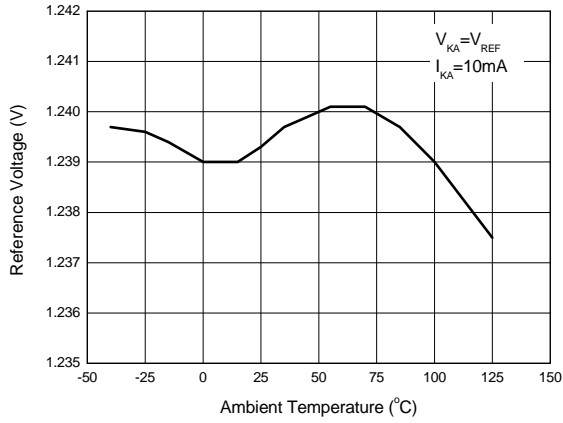

Figure 7. Reference Voltage vs. Ambient Temperature

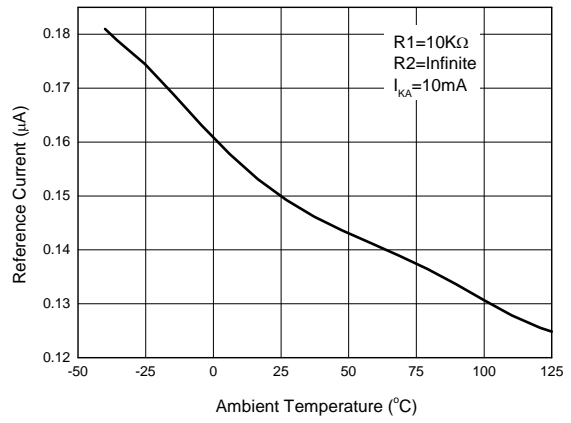

Figure 8. Reference Current vs. Ambient Temperature

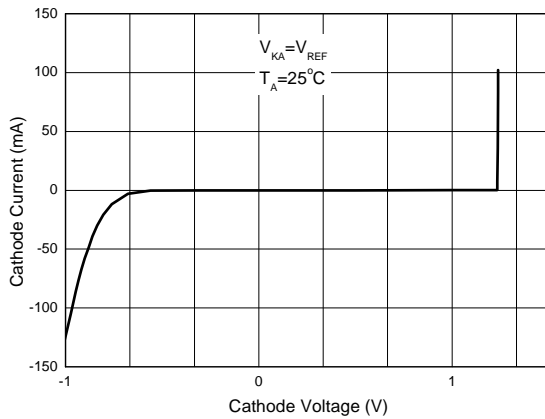

Figure 9. Cathode Current vs. Cathode Voltage

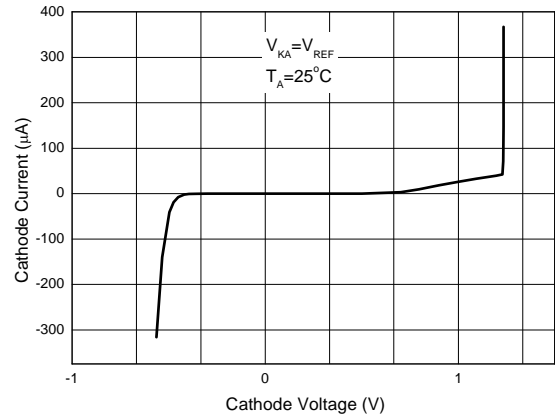

Figure 10. Cathode Current vs. Cathode Voltage



LOW VOLTAGE (1.24V) ADJUSTABLE PRECISION SHUNT REGULATOR

AZ431L

Typical Performance Characteristics (Continued)

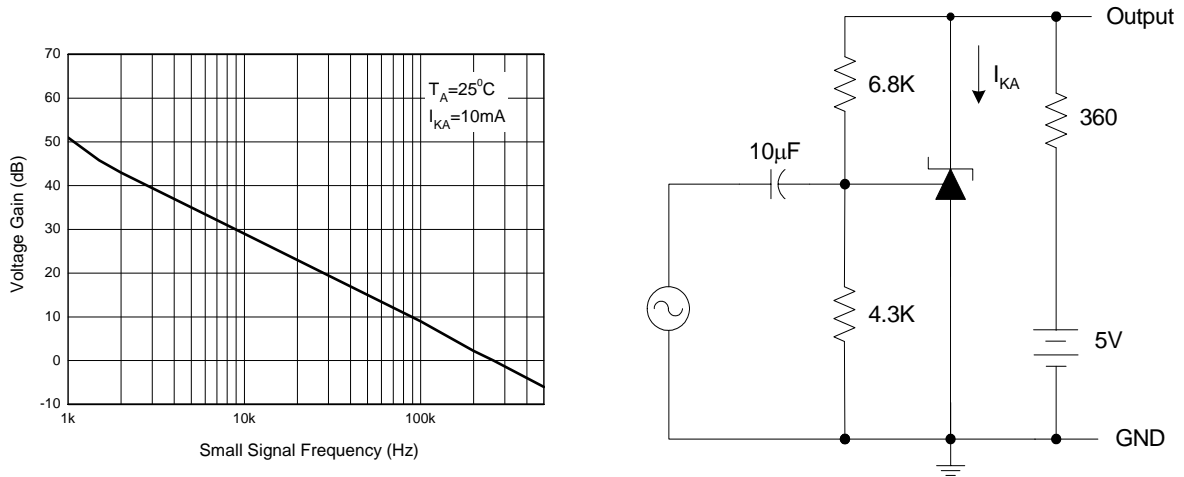

Figure 11. Small Signal Voltage Gain vs. Frequency

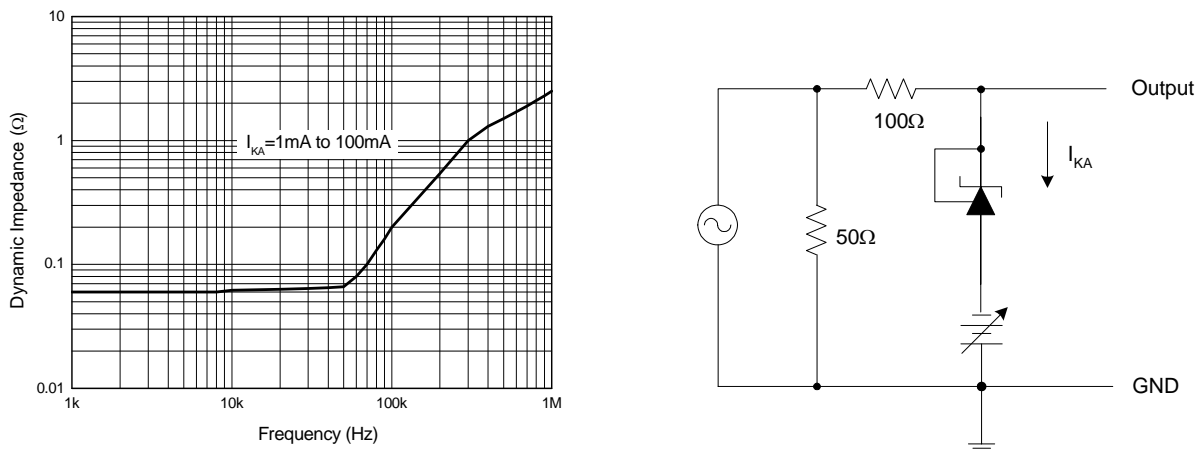

Figure 12. Dynamic Impedance vs. Frequency



LOW VOLTAGE (1.24V) ADJUSTABLE PRECISION SHUNT REGULATOR

AZ431L

Typical Performance Characteristics (Continued)

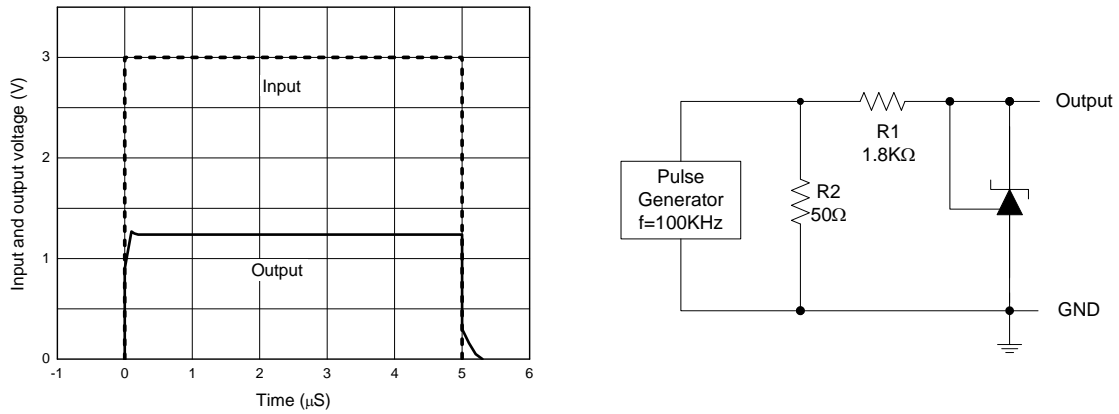

Figure 13. Pulse Response of Input and Output Voltage

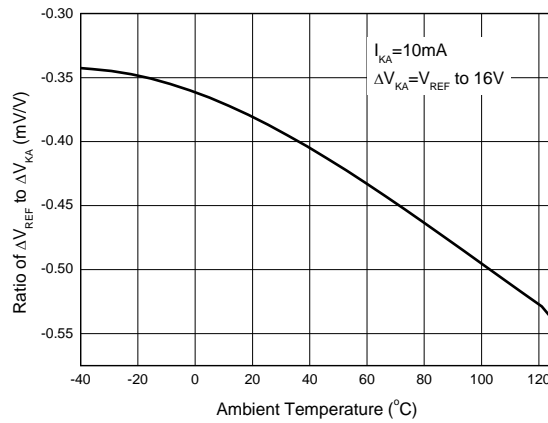

Figure 14. Ratio of Delta Reference Voltage to the Ratio of Cathode Voltage vs. Ambient Temperature



LOW VOLTAGE (1.24V) ADJUSTABLE PRECISION SHUNT REGULATOR

AZ431L

Typical Applications

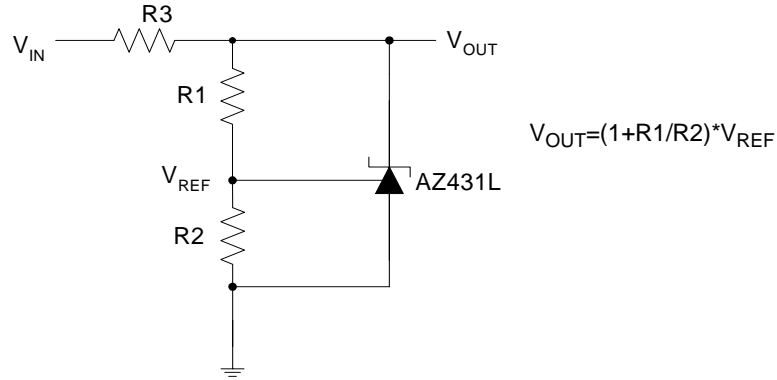

Figure 15. Shunt Regulator

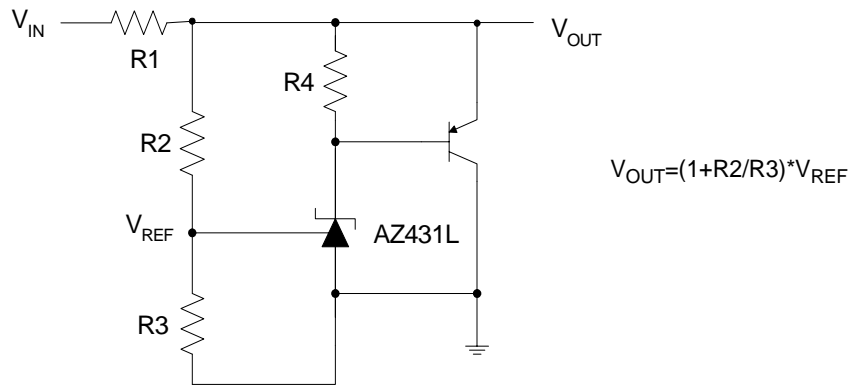

Figure 16. High Current Shunt Regulator

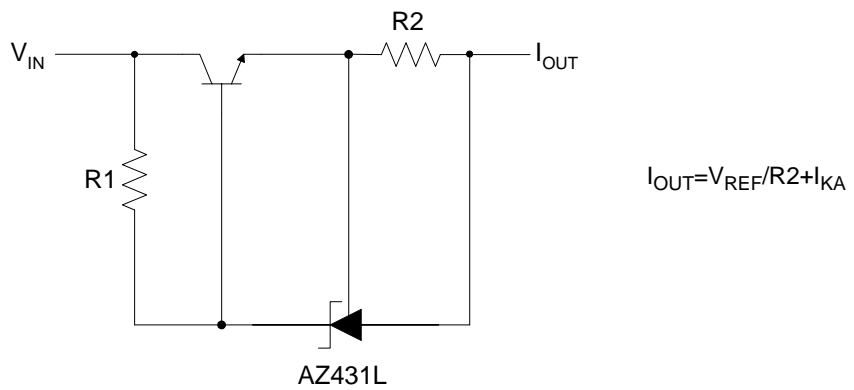

Figure 17. Current Source or Current Limit



LOW VOLTAGE (1.24V) ADJUSTABLE PRECISION SHUNT REGULATOR

AZ431L

Typical Application (Continued)

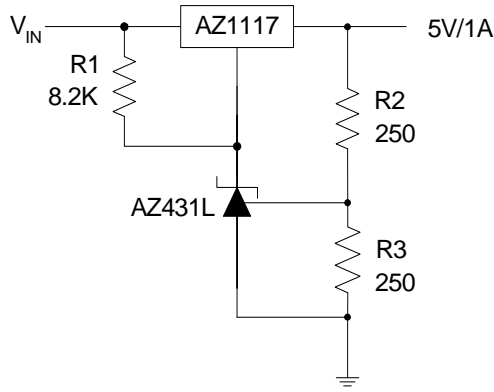

Figure18. Precision 5V 1A Regulator

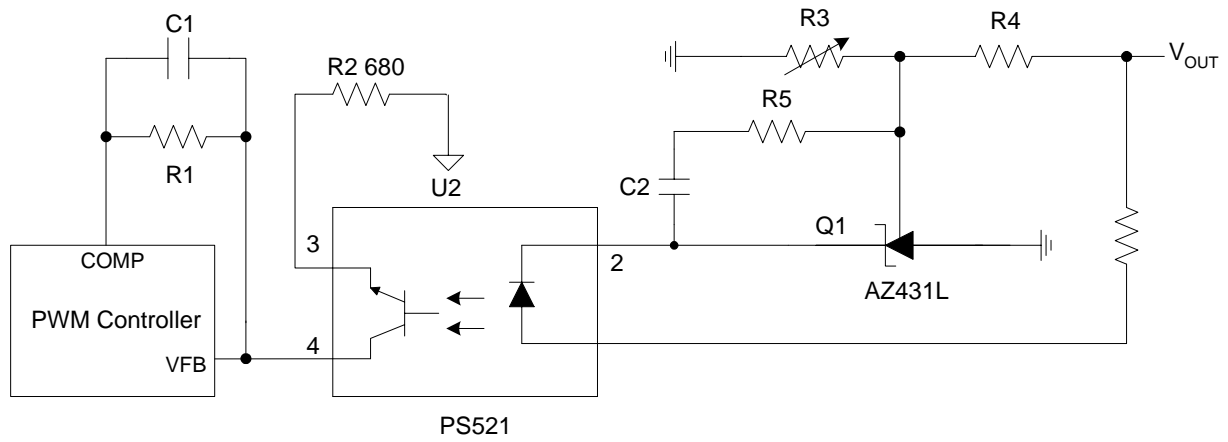

Figure 19. PWM Converter with Reference



LOW VOLTAGE (1.24V) ADJUSTABLE PRECISION SHUNT REGULATOR

AZ431L

Mechanical Dimensions

TO-92

Unit: mm(inch)

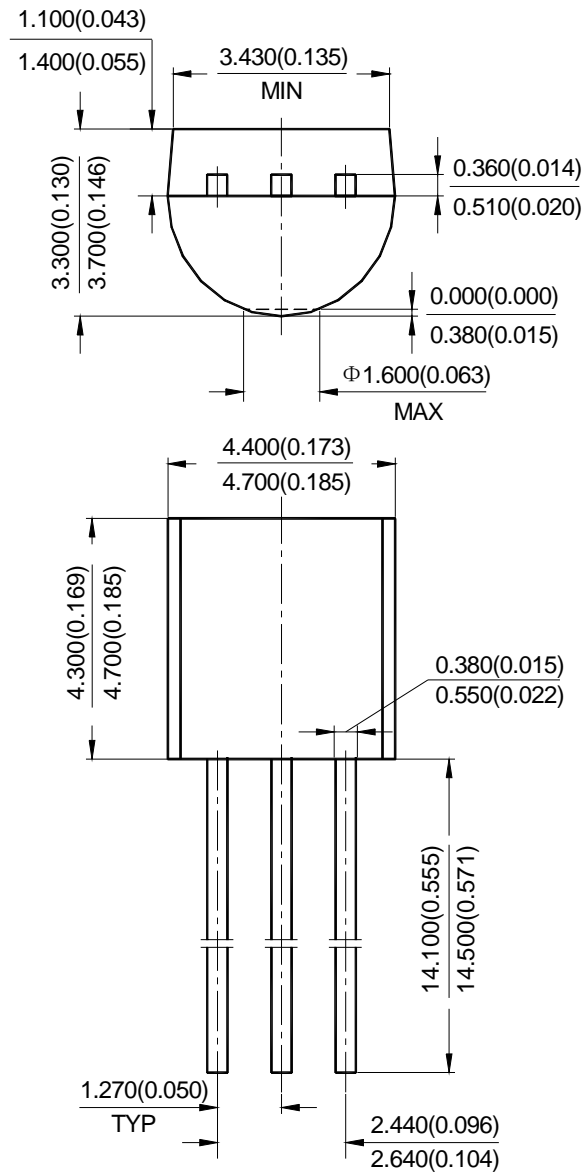



LOW VOLTAGE (1.24V) ADJUSTABLE PRECISION SHUNT REGULATOR

AZ431L

Mechanical Dimensions (Continued)

SOT-23

Unit: mm(inch)

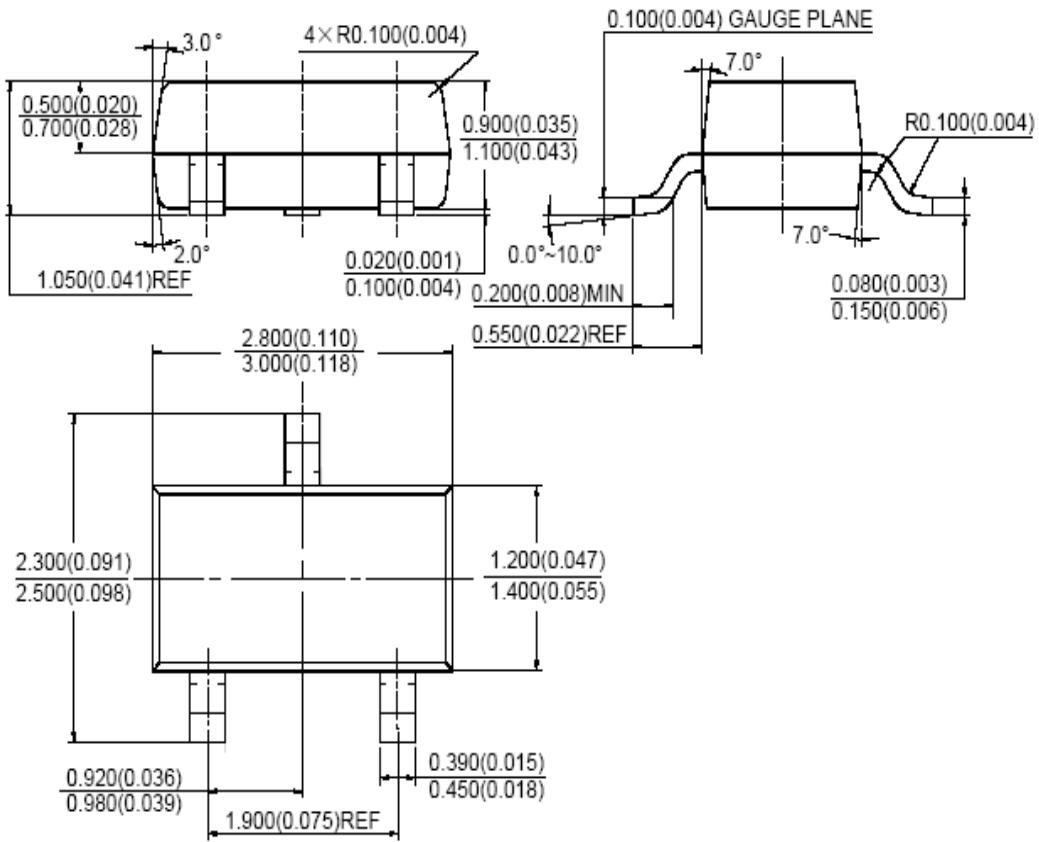



LOW VOLTAGE (1.24V) ADJUSTABLE PRECISION SHUNT REGULATOR

AZ431L

Mechanical Dimensions (Continued)

SOT-23-5

Unit: mm(inch)

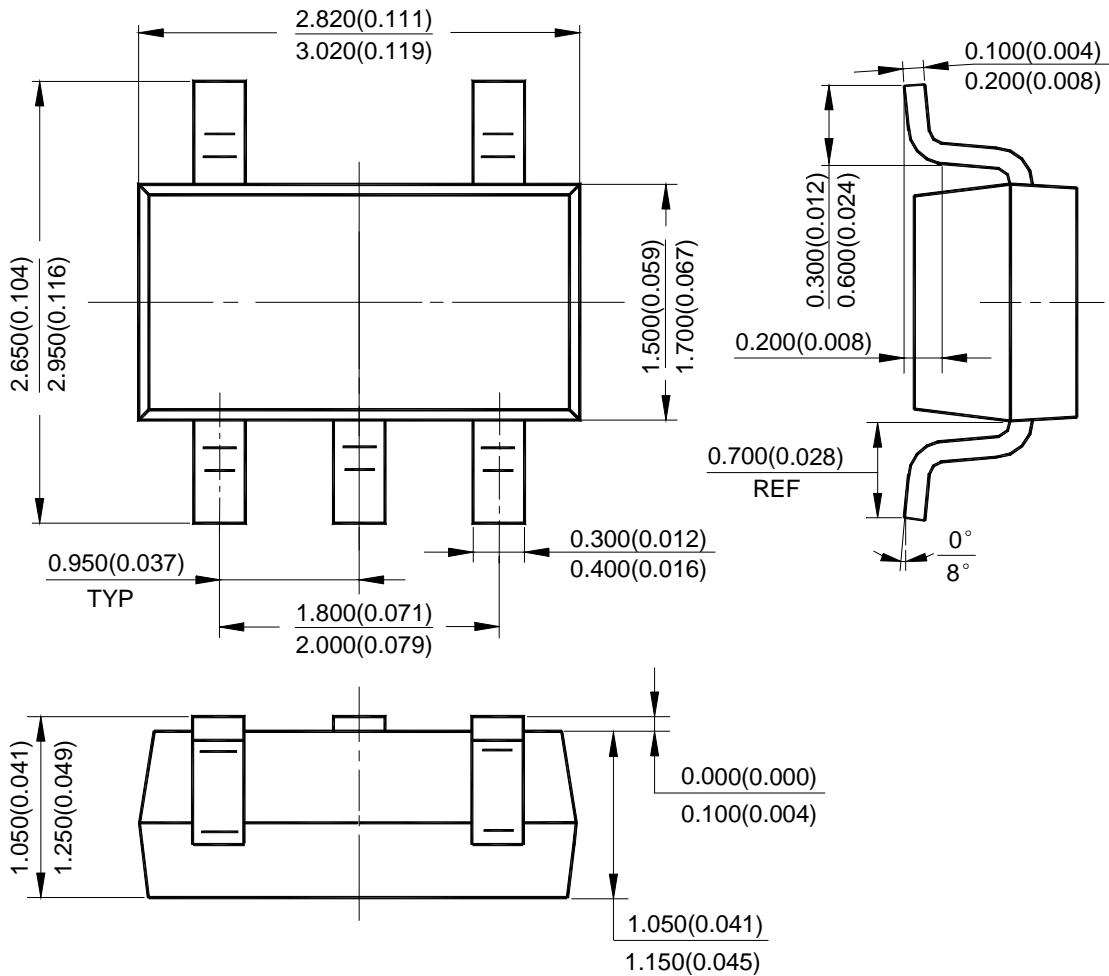



BCD Semiconductor Manufacturing Limited

<http://www.bcdsemi.com>

IMPORTANT NOTICE

BCD Semiconductor Manufacturing Limited reserves the right to make changes without further notice to any products or specifications herein. BCD Semiconductor Manufacturing Limited does not assume any responsibility for use of any its products for any particular purpose, nor does BCD Semiconductor Manufacturing Limited assume any liability arising out of the application or use of any its products or circuits. BCD Semiconductor Manufacturing Limited does not convey any license under its patent rights or other rights nor the rights of others.

MAIN SITE

BCD Semiconductor Manufacturing Limited
- Wafer Fab
Shanghai SIM-BCD Semiconductor Manufacturing Limited
800, Yi Shan Road, Shanghai 200233, China
Tel: +86-21-6485 1491, Fax: +86-21-5450 0008

BCD Semiconductor Manufacturing Limited
- IC Design Group
Advanced Analog Circuits (Shanghai) Corporation
8F, Zone B, 900, Yi Shan Road, Shanghai 200233, China
Tel: +86-21-6495 9539, Fax: +86-21-6485 9673

REGIONAL SALES OFFICE

Shenzhen Office
Shanghai SIM-BCD Semiconductor Manufacturing Co., Ltd. Shenzhen Office
Advanced Analog Circuits (Shanghai) Corporation Shenzhen Office
Room E, 5F, Noble Center, No.1006, 3rd Fuzhong Road, Futian District, Shenzhen 518026, China
Tel: +86-755-8826 7951
Fax: +86-755-8826 7865

Taiwan Office
BCD Semiconductor (Taiwan) Company Limited
4F, 298-1, Rui Guang Road, Nei-Hu District, Taipei,
Taiwan
Tel: +886-2-2656 2808
Fax: +886-2-2656 2806

USA Office
BCD Semiconductor Corporation
30920 Huntwood Ave. Hayward,
CA 94544, U.S.A
Tel : +1-510-324-2988
Fax: +1-510-324-2788