



## STN83003

High voltage fast-switching  
NPN power transistor

### General features

- Medium voltage capability
- Low spread of dynamic parameters
- Minimum lot-to-lot spread for reliable operation
- Very high switching speed
- SOT-223 plastic package for surface mounting circuits
- Tape and reel packing

### Applications

- Electronics ballasts for fluorescent lighting
- Switch mode power supplies

### Description

The device is manufactured using high voltage Multi-Epitaxial Planar technology for high switching speeds and medium voltage capability. It uses a Cellular Emitter structure with planar edge termination to enhance switching speeds while maintaining the wide RBSOA.

The STN83003 is expressly designed for a new solution to be used in compact fluorescent lamps, where it is coupled with the STN93003, its complementary PNP transistor.

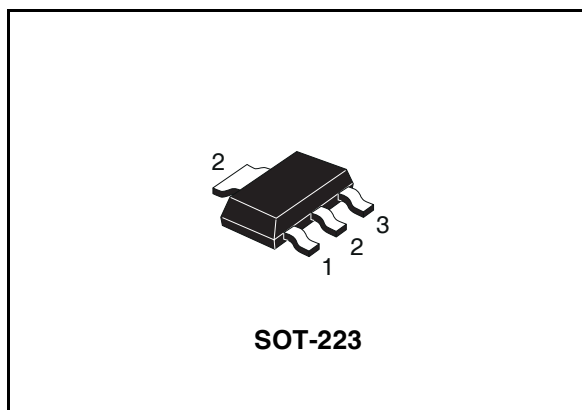

### Internal schematic diagrams

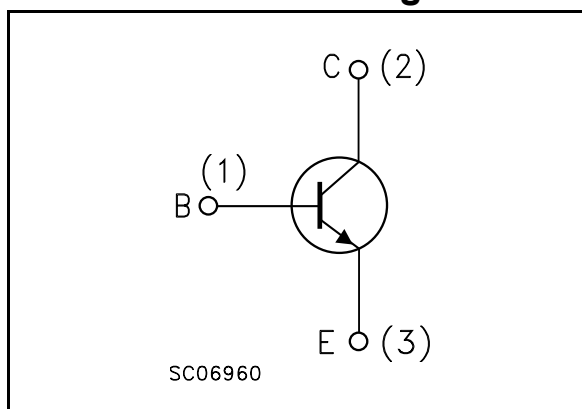

### Order codes

Part Number	Marking	Package	Packing
STN83003	N83003	SOT-223	Tape & reel

# Contents

<b>1</b>	<b>Electrical ratings</b> .....	<b>3</b>
<b>2</b>	<b>Electrical characteristics</b> .....	<b>4</b>
2.1	Electrical characteristics (curves) .....	5
2.2	Test circuits .....	7
<b>3</b>	<b>Package mechanical data</b> .....	<b>8</b>
<b>4</b>	<b>Revision history</b> .....	<b>10</b>

# 1 Electrical ratings

**Table 1. Absolute maximum rating**

Symbol	Parameter	Value	Unit
$V_{CES}$	Collector-emitter voltage ( $V_{BE} = 0$ )	700	V
$V_{CEO}$	Collector-emitter voltage ( $I_B = 0$ )	400	V
$V_{EBO}$	Emitter-base voltage ( $I_C = 0$ , $I_B = 0.75A$ , $t_p < 10\mu s$ , $T_j < 150^\circ C$ )	$V_{(BR)EBO}$	V
$I_C$	Collector current	1.5	A
$I_{CM}$	Collector peak current ( $t_p < 5ms$ )	3	A
$I_B$	Base current	0.75	A
$I_{BM}$	Base peak current ( $t_p < 5ms$ )	1.5	A
$P_{tot}$	Total dissipation at $T_c = 25^\circ C$	1.6	W
$T_{stg}$	Storage temperature	-65 to 150	$^\circ C$
$T_J$	Max. operating junction temperature	150	$^\circ C$

**Table 2. Thermal data**

Symbol	Parameter	Value	Unit
$R_{thj-amb}$	Thermal resistance junction-ambient <sup>(1)</sup> max	78	$^\circ C/W$

1. Device mounted on PCB area of 1 cm<sup>2</sup>.

## 2 Electrical characteristics

( $T_{\text{case}} = 25^{\circ}\text{C}$  unless otherwise specified)

**Table 3. Electrical characteristics**

Symbol	Parameter	Test Conditions	Min.	Typ.	Max.	Unit
$I_{\text{CEV}}$	Collector cut-off current ( $V_{\text{BE}} = -1.5\text{V}$ )	$V_{\text{CE}} = 700\text{V}$ $V_{\text{CE}} = 700\text{V}$ $T_{\text{j}} = 125^{\circ}\text{C}$			1 5	mA mA
$V_{(\text{BR})\text{EBO}}$	Emitter-base breakdown voltage ( $I_{\text{C}} = 0$ )	$I_{\text{E}} = 10\text{mA}$	12		18	V
$V_{\text{CE(sus)}}^{(1)}$	Collector-emitter sustaining voltage ( $I_{\text{B}} = 0$ )	$I_{\text{C}} = 10\text{mA}$ $L = 25\text{mH}$	400			V
$V_{\text{CE(sat)}}^{(1)}$	Collector-emitter saturation voltage	$I_{\text{C}} = 0.35\text{A}$ $I_{\text{B}} = 50\text{mA}$ $I_{\text{C}} = 0.5\text{A}$ $I_{\text{B}} = 0.1\text{A}$			1 0.5	V V
$V_{\text{BE(sat)}}^{(1)}$	Base-emitter saturation voltage	$I_{\text{C}} = 0.5\text{A}$ $I_{\text{B}} = 0.1\text{A}$			1	V
$h_{\text{FE}}$	DC current gain	$I_{\text{C}} = 10\text{mA}$ $V_{\text{CE}} = 5\text{V}$ $I_{\text{C}} = 0.35\text{A}$ $V_{\text{CE}} = 5\text{V}$ $I_{\text{C}} = 1\text{A}$ $V_{\text{CE}} = 5\text{V}$	10 16 4	25	32	
$t_{\text{r}}$ $t_{\text{s}}$ $t_{\text{f}}$	Resistive load Rise time Storage time Fall time	$I_{\text{C}} = 0.35\text{A}$ $V_{\text{CC}} = 125\text{V}$ $I_{\text{B1}} = -I_{\text{B2}} = 70\text{mA}$ $T_{\text{P}} \geq 25\mu\text{s}$ (see figure 10)	1.5	100 2.2 0.2	2.9	ns $\mu\text{s}$ $\mu\text{s}$
$t_{\text{s}}$ $t_{\text{f}}$	Inductive load Storage time Fall time	$I_{\text{C}} = 0.5\text{A}$ $I_{\text{B1}} = 0.1\text{A}$ $V_{\text{BE(off)}} = -5\text{V}$ $L = 10\text{mH}$ $V_{\text{Clamp}} = 300\text{V}$ (see figure 9)		450 90		ns ns

1. Pulsed duration = 300  $\mu\text{s}$ , duty cycle  $\leq 1.5\%$

## 2.1 Electrical characteristics (curves)

Figure 1. Safe operating area

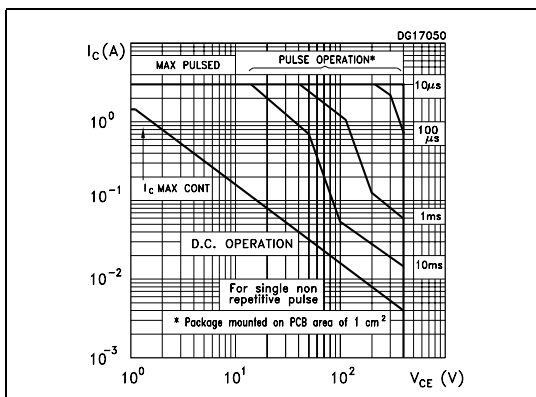

Figure 2. DC Current Gain

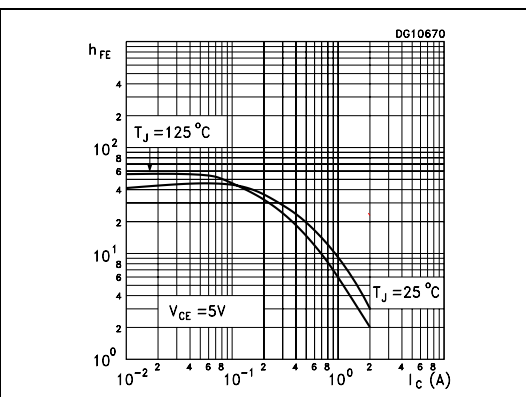

Figure 3. DC Current Gain

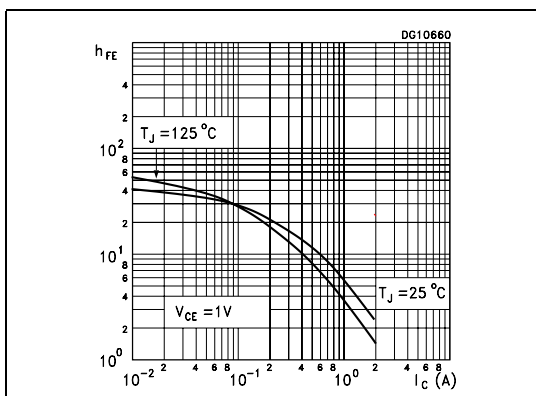

Figure 4. Collector-emitter saturation voltage

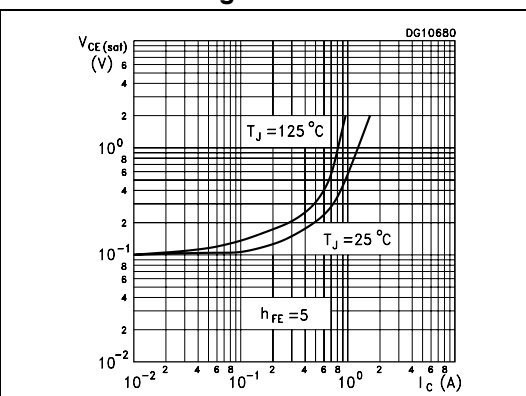

Figure 5. Base-emitter saturation voltage

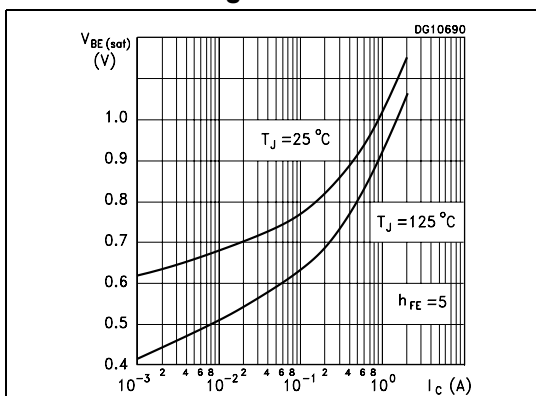

Figure 6. Resistive load storage time

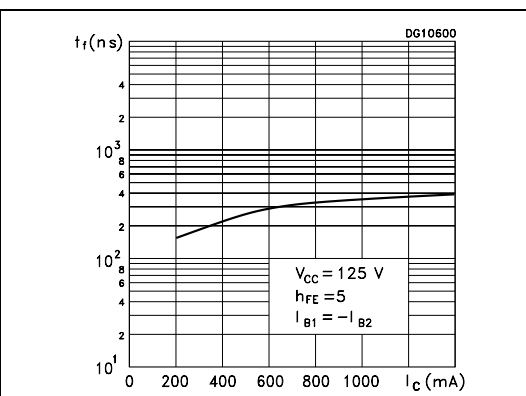

Figure 7. Resistive load storage time

Figure 8. Inductive load storage time

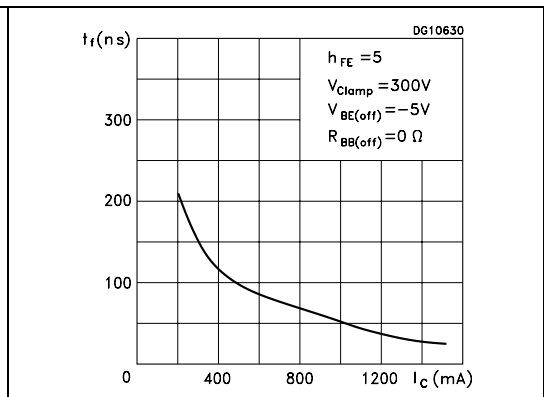
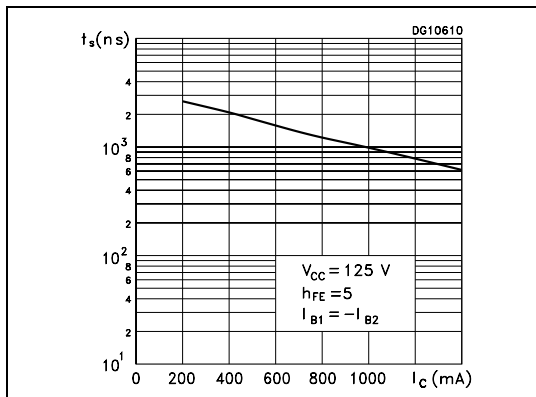
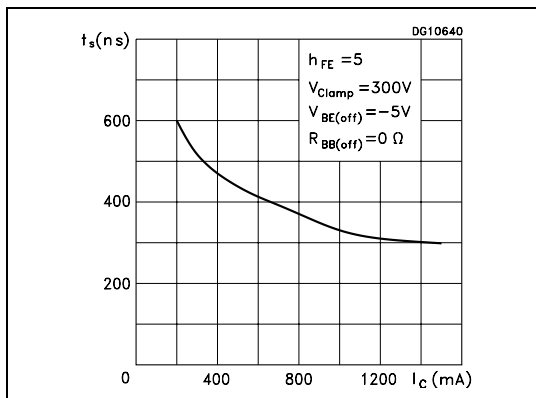
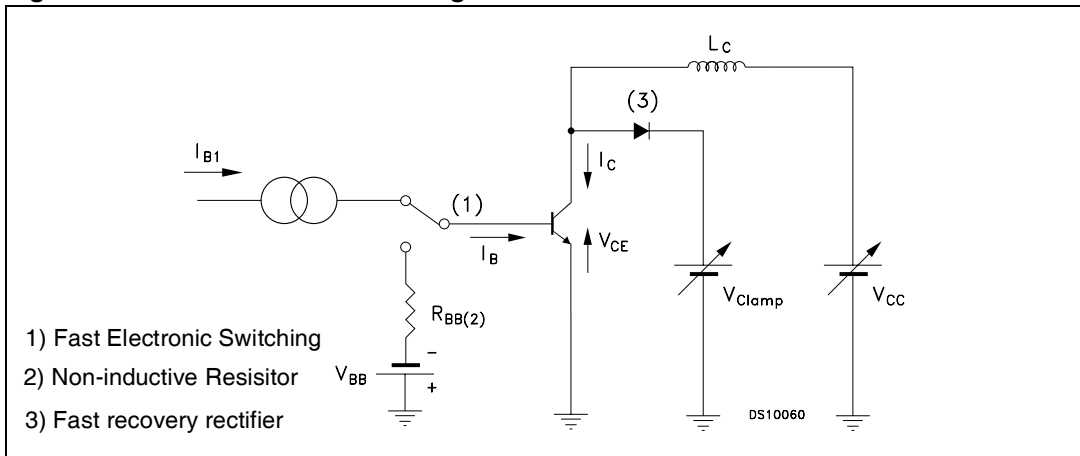

Figure 9. Inductive load fall time



## 2.2 Test circuits

**Figure 10. Inductive load switching test circuit**



**Figure 11. Resistive load switching test circuit**

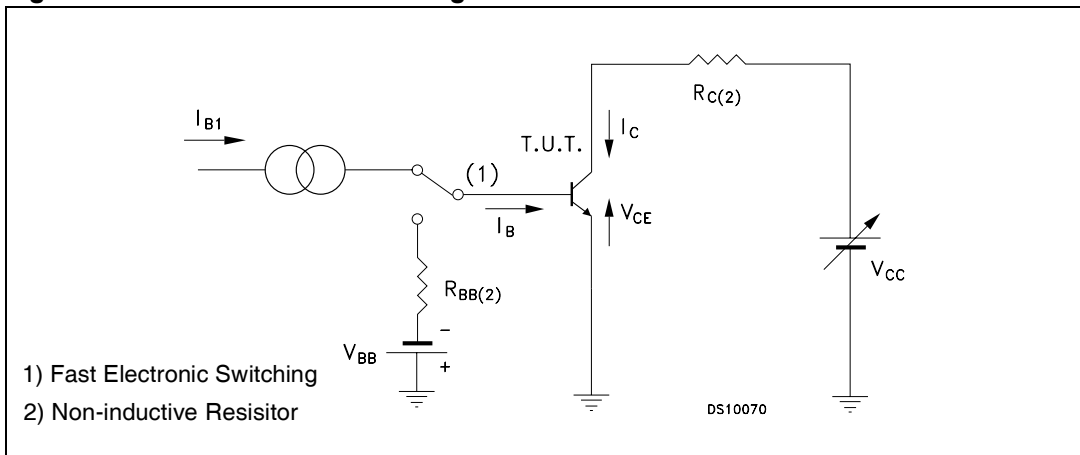

### 3 Package mechanical data

In order to meet environmental requirements, ST offers these devices in ECOPACK® packages. These packages have a Lead-free second level interconnect. The category of second level interconnect is marked on the package and on the inner box label, in compliance with JEDEC Standard JESD97. The maximum ratings related to soldering conditions are also marked on the inner box label. ECOPACK is an ST trademark. ECOPACK specifications are available at: [www.st.com](http://www.st.com)



SOT-223 MECHANICAL DATA

DIM.	mm			inch		
	MIN.	TYP.	MAX.	MIN.	TYP.	MAX.
A			1.80			0.071
B	0.60	0.70	0.80	0.024	0.027	0.031
B1	2.90	3.00	3.10	0.114	0.118	0.122
c	0.24	0.26	0.32	0.009	0.010	0.013
D	6.30	6.50	6.70	0.248	0.256	0.264
e		2.30			0.090	
e1		4.60			0.181	
E	3.30	3.50	3.70	0.130	0.138	0.146
H	6.70	7.00	7.30	0.264	0.276	0.287
V			10°			10°
A1		0.02				

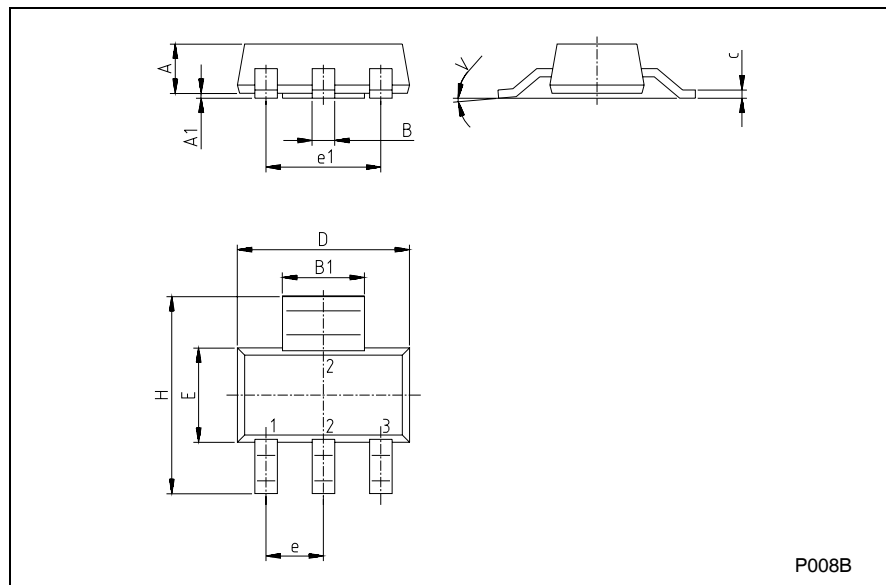

## 4 Revision history

**Table 4. Revision history**

Date	Revision	Changes
09-May-2006	1	Initial release.
17-Jan-2007	2	The device's safe operating area curve has been added on page 5.

**Please Read Carefully:**

Information in this document is provided solely in connection with ST products. STMicroelectronics NV and its subsidiaries ("ST") reserve the right to make changes, corrections, modifications or improvements, to this document, and the products and services described herein at any time, without notice.

All ST products are sold pursuant to ST's terms and conditions of sale.

Purchasers are solely responsible for the choice, selection and use of the ST products and services described herein, and ST assumes no liability whatsoever relating to the choice, selection or use of the ST products and services described herein.

No license, express or implied, by estoppel or otherwise, to any intellectual property rights is granted under this document. If any part of this document refers to any third party products or services it shall not be deemed a license grant by ST for the use of such third party products or services, or any intellectual property contained therein or considered as a warranty covering the use in any manner whatsoever of such third party products or services or any intellectual property contained therein.

**UNLESS OTHERWISE SET FORTH IN ST'S TERMS AND CONDITIONS OF SALE ST DISCLAIMS ANY EXPRESS OR IMPLIED WARRANTY WITH RESPECT TO THE USE AND/OR SALE OF ST PRODUCTS INCLUDING WITHOUT LIMITATION IMPLIED WARRANTIES OF MERCHANTABILITY, FITNESS FOR A PARTICULAR PURPOSE (AND THEIR EQUIVALENTS UNDER THE LAWS OF ANY JURISDICTION), OR INFRINGEMENT OF ANY PATENT, COPYRIGHT OR OTHER INTELLECTUAL PROPERTY RIGHT.**

**UNLESS EXPRESSLY APPROVED IN WRITING BY AN AUTHORIZED REPRESENTATIVE OF ST, ST PRODUCTS ARE NOT RECOMMENDED, AUTHORIZED OR WARRANTED FOR USE IN MILITARY, AIR CRAFT, SPACE, LIFE SAVING, OR LIFE SUSTAINING APPLICATIONS, NOR IN PRODUCTS OR SYSTEMS, WHERE FAILURE OR MALFUNCTION MAY RESULT IN PERSONAL INJURY, DEATH, OR SEVERE PROPERTY OR ENVIRONMENTAL DAMAGE. ST PRODUCTS WHICH ARE NOT SPECIFIED AS "AUTOMOTIVE GRADE" MAY ONLY BE USED IN AUTOMOTIVE APPLICATIONS AT USER'S OWN RISK.**

Resale of ST products with provisions different from the statements and/or technical features set forth in this document shall immediately void any warranty granted by ST for the ST product or service described herein and shall not create or extend in any manner whatsoever, any liability of ST.

ST and the ST logo are trademarks or registered trademarks of ST in various countries.

Information in this document supersedes and replaces all information previously supplied.

The ST logo is a registered trademark of STMicroelectronics. All other names are the property of their respective owners.

© 2007 STMicroelectronics - All rights reserved

STMicroelectronics group of companies

Australia - Belgium - Brazil - Canada - China - Czech Republic - Finland - France - Germany - Hong Kong - India - Israel - Italy - Japan - Malaysia - Malta - Morocco - Singapore - Spain - Sweden - Switzerland - United Kingdom - United States of America

[www.st.com](http://www.st.com)

