



RE46C112

Ionization Smoke Detector IC
Product Specification

General Description

The RE46C112 is an ionization type smoke detector IC. It is intended for applications using ionization type chambers to detect smoke. When enabled, VOUT is ¼ of either the DETECT input or VDD depending on the status of the SELECT input. When the Select input is allowed to float the circuit is in the low current mode with only the guard amplifier enabled.

Utilizing low power CMOS technology the RE46C112 was designed for use in smoke detectors that comply with Underwriters Laboratory Specification UL217.

Features

- Guard Outputs for Ion Detector Input
- ± 0.75pA Detect Input Current
- Microprocessor A/D Compatible Analog Output
- Low Quiescent Current Consumption (<10uA)
- Available in 8L PDIP or 8L N SOIC
- 2000V ESD Protection (HBM)
- Available in Standard Packaging or RoHS Compliant Pb Free Packaging

Pin Configuration

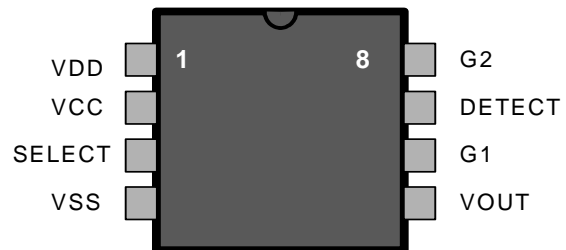

ABSOLUTE MAXIMUM RATINGS

PARAMETER	SYMBOL	VALUE	UNITS
Supply Voltage	V _{DD}	12.5	V
Supply Voltage	V _{CC}	6	V
Detect Input Voltage Range	V _{INDET}	V _{DD} +.3	V
SELECT Input Voltage Range	V _{INSEL}	V _{CC} +.3	V
Operating Temperature	T _A	-10 to 60	°C
Storage Temperature	T _{STG}	-55 to 125	°C
Maximum Junction Temperature	T _J	150	°C

Stresses beyond those listed under Absolute Maximum Ratings may cause permanent damage to the device. These are stress ratings only and operation at these conditions for extended periods may affect device reliability.

This product utilizes CMOS technology with static protection; however proper ESD prevention procedures should be used when handling this product. Damage can occur when exposed to extremely high static electrical charge

RE46C112

Ionization Smoke Detector IC
Product Specification



R&E International

Electrical Characteristics at TA = 25°C, VDD=9V, VCC=5V, VSS=0V (unless otherwise noted)

Parameter	Symbol	Test Pin	Test Conditions	Limits			
				Min	Typ	Max	Units
Supply Voltage	V _{DD}	1	Operating	6		12	V
	V _{CC}	2	Operating	2.7		5.5	V
Supply Current	I _{BD}	1	SELECT=open, DETECT=4.5V, VDD=9V		3	4.5	uA
		1	SELECT=open, DETECT=6V, VDD=12V		4	5.5	uA
		1	SELECT=VCC or VSS, DETECT=4.5V, VDD=9V		60	90	uA
	I _{CC}	2	SELECT=open, VCC=5V, DETECT=4.5V, VDD=9V		2.75	4.3	uA
		2	SELECT=open, VCC=3V, DETECT=6V, VDD=12V		1	1.75	uA
Input Voltage High	V _{ih}	3	SELECT	V _{CC} -4			V
Input Voltage Low	V _{il}	3	SELECT			0.4	V
Input Leakage	I _{Ldet}	7	VDD=12V, DETECT=VDD or VSS, 0-40% RH	-0.75		0.75	pA
			VDD=12V, DETECT=VDD or VSS, 85% RH, See Note 1	-1.5		1.5	pA
	I _{Lsel}	3	SELECT=VCC or VSS VCC=5V	-15		45	uA
			SELECT=VCC or VSS VCC=3V	-4		15	uA
Offset Voltage	V _{GOS}	6,8		-50		50	mV
Common Mode Voltage	V _{CM}	7	Guard Amplifier	2		V _{DD} -5	V
Output Impedance		6,8	Guard Amplifier			10	k \square
Output Voltage	V _{out}	5	VDD=6V to 12V, SELECT=VSS, RL=10K	-2% - 20mV	.25*V _{DD}	2% + 20mV	V
		5	DETECT= 2V to VDD-.5V, SELECT=VCC, RL=10K	-2% - 20mV	.25*V _{DETECT}	2% + 20mV	V

Note 1 : Sample test only



PIN DESCRIPTIONS

Pin 1 (VDD) - This pin should be connected to the most positive supply potential, typically a 9 Volt battery. The VDD voltage can range between 6V and 12V with respect to VSS. Reverse battery protection must be provided externally.

Pin 2 (VCC) – This positive supply potential can range between 2.7V and 5.5V with respect to VSS and must be less than the VDD voltage. This pin is usually connected to a microprocessor positive supply voltage.

PIN 3 (SELECT) – This input pin determines the function of VOUT. This pin is typically driven by a microprocessor port. The input high level should not exceed VCC. If left floating VOUT is inactive and pulled internally to VSS. If SELECT is at the VIL (low) level then VOUT is nominally $\frac{1}{4}$ of the VDD voltage. If SELECT is at the VIH level (high) then VOUT is nominally $\frac{1}{4}$ of the DETECT voltage.

PIN 4 (VSS) – This pin is the negative supply potential and is usually connected to ground.

PIN 5 (VOUT) – This analog output is a representation of VDD or DETECT or is at VSS depending on the status of the SELECT input. Typically this output is connected to a microprocessor A to D input to monitor the status of the supply voltage and the ionization chamber voltage.

PIN 6, 8 (G1, G2) – These pins are connected to the internal guard amplifier output and are within $\pm 50\text{mV}$ of the DETECT input. These outputs are always active and help to minimize surface leakage to the DETECT pin.

PIN 7 (DETECT) - This input is typically interfaced to an ionization chamber to sense the presence of smoke. Input leakage is less than $\pm 75\text{pA}$ on this input.

RE46C112

Ionization Smoke Detector IC
Product Specification



R&E International

Functional Block Diagram

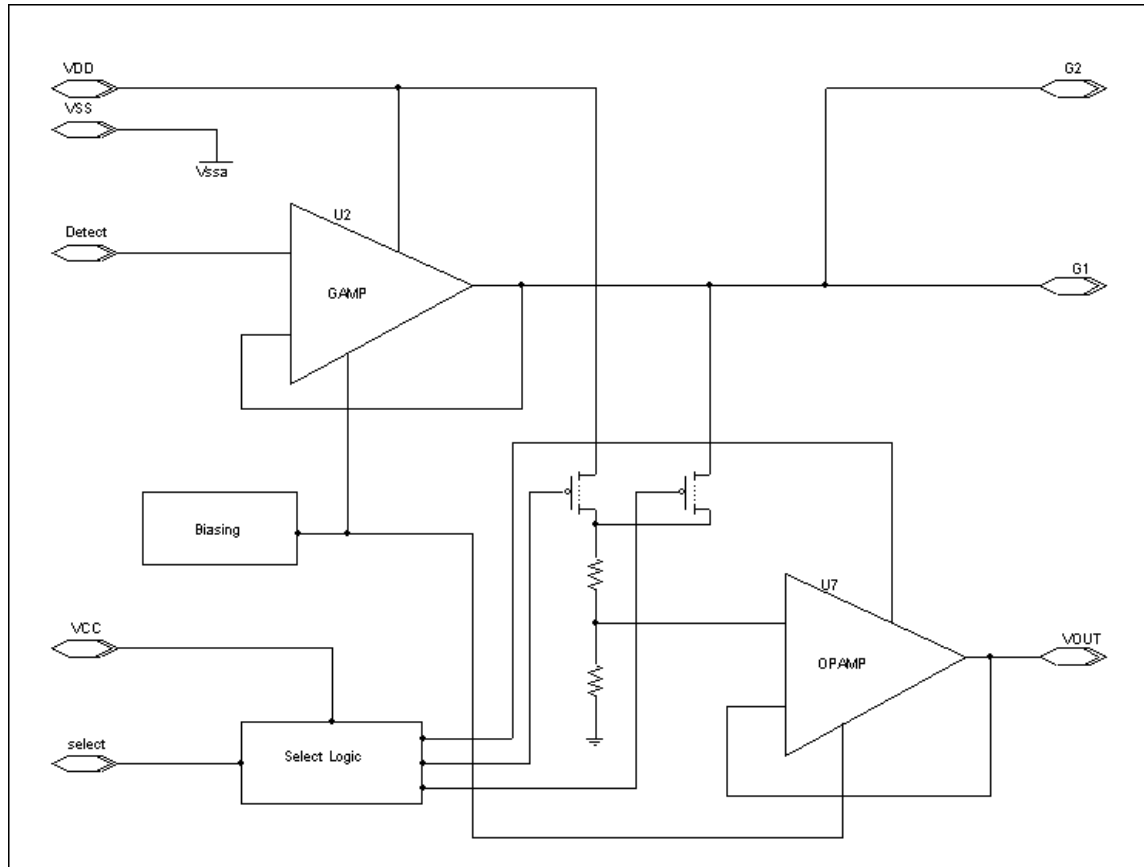

Figure 1

RE46C112

Ionization Smoke Detector IC
Product Specification



R&E International

Typical Application

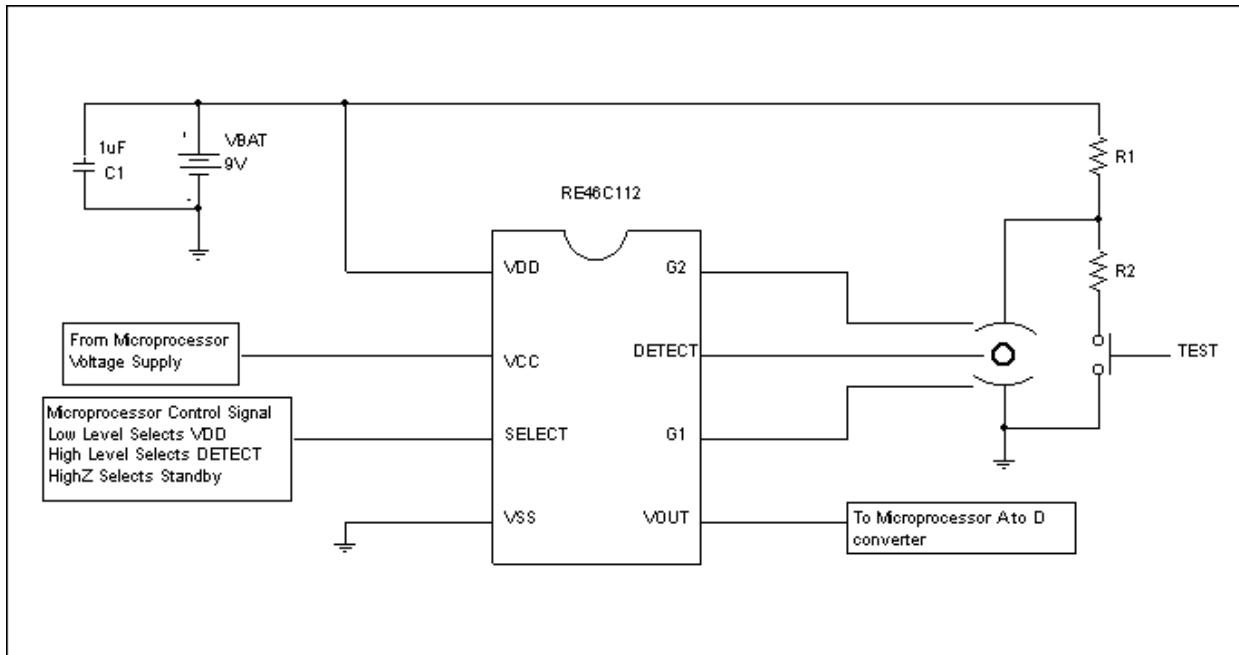

Figure 2

R&E INTERNATIONAL, Inc. reserves the right to make changes without further notice to any products herein to improve reliability, function or design.

R&E INTERNATIONAL, Inc. does not assume any liability arising out of the application or use of any product or circuit described herein; neither does it convey any license under its patent rights, nor the rights of others.

R&E INTERNATIONAL, Inc. products are not authorized for use as critical components in life support devices or systems without the express written approval of the President of **R&E INTERNATIONAL, Inc.** Life support devices or systems are devices or systems which are intended for surgical implant into the body to support or sustain life, and whose failure to perform, when properly used in accordance with instructions for use provided in the labeling, can be reasonably expected to result in a significant injury to the user. A critical component is any component of a life support device or system whose failure to perform can be reasonably expected to cause the failure of the life support device or system, or to affect its safety or effectiveness.