

SP6T GaAs Multi-Band GSM Antenna Switch

FEATURES:

- Available in die form
- Very low Tx Insertion loss
- High Tx-Rx isolation >45dB typ. at 1.8GHz
- High Tx-Tx isolation >30dB typ. at 1.8GHz
- Excellent low control voltage performance
- Excellent harmonic performance

GENERAL DESCRIPTION:

FMS2028 is a low loss, high power single pole six throw Gallium Arsenide antenna switch. The die is fabricated using the Filtronic FL05 0.5 μ m switch process technology that offers leading edge performance optimised for switch applications. FMS2028 is designed for use in dual-, tri- and quad-band GSM handset antenna switch and RF front-end modules.

FUNCTIONAL SCHEMATIC:

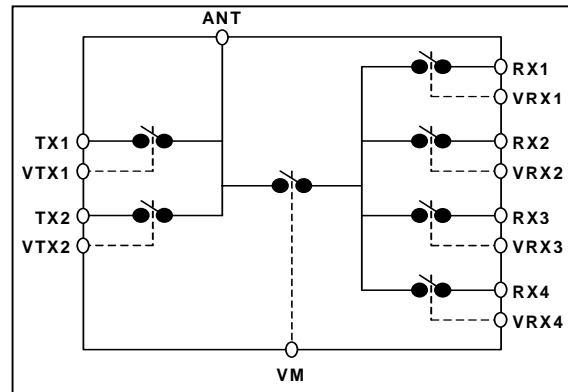

TYPICAL APPLICATIONS:

- Suitable for multi-band GSM/DCS/PCS/EDGE applications

ELECTRICAL SPECIFICATIONS:

PARAMETER	CONDITIONS ⁽¹⁾	MIN	TYP	MAX	UNITS
Tx Insertion Loss	0.9 GHz	0	0.4	0.55	dB
	1.8 GHz	0	0.41	0.6	dB
Rx Insertion Loss	0.9 GHz	0	0.73	1	dB
	1.8 GHz	0	1.0	1.2	dB
Return Loss	0.5 – 2.5 GHz	—	23	—	dB
Isolation (TX-TX)	0.9 GHz	26	28.5	55	dB
	1.8 GHz	19.5	21	45	dB
Isolation (TX-RX)	0.9 GHz	42	47	55	dB
	1.8 GHz	37	42	55	dB
Isolation (RX-RX)	0.5 – 1.0 GHz	26	28	—	dB
	1.0 – 2.0 GHz	20	22	—	dB
P _{0.1dB}	0.9 GHz, CW	—	37	—	dBm
2nd Harmonic Level	0.9 GHz, Pin = +35 dBm, CW ⁽²⁾	-100	-80	-70	dBc
	1.8 GHz, Pin = +33 dBm, CW ⁽²⁾	-100	-80	-70	dBc
3rd Harmonic Level	0.9 GHz, Pin = +35 dBm, CW ⁽²⁾	-100	-68	-65	dBc
	1.8 GHz, Pin = +33 dBm, CW ⁽²⁾	-100	-72	-65	dBc
Switching speed	10% to 90% RF and 90% to 10% RF, Pin = 0 dBm	—	—	0.3	μ s
	50% control to 90% RF and 50% control to 90% RF, Pin = 0 dBm	—	—	1	μ s
Control Current	V _{ctrl} = 0 / 2.7 V, Pin = 35 dBm, 0.9 GHz	0.01	12	40	μ A
	V _{ctrl} = 0 / 2.7 V, Pin = 0 dBm, 1.8 GHz	0.01	1.3	4	μ A

Note 1: T_{AMBIENT} = 25°C, V_{ctrl} = 0V/2.7V, Z_{IN} = Z_{OUT} = 50 Ω

Note 2: Measured harmonic values are dependant upon system termination impedances at the harmonic frequency

ABSOLUTE MAXIMUM RATINGS:

PARAMETER	SYMBOL	ABSOLUTE MAXIMUM
Max Input Power	P_{in}	+38dBm
Control Voltage	V_{ctrl}	+6V
Operating Temp	T_{oper}	-40°C to +100°C
Storage Temp	T_{stor}	-55°C to +150°C

Note: Exceeding any one of these absolute maximum ratings may cause permanent damage to the device.

BONDPADS COORDINATES:

PAD REF	PAD NAME	DESCRIPTION	PIN COORDINATES (μM)
A	Tx1	TX1 RF Output	(125.9, 121.4)
B	VRx1	Rx1 Control Voltage	(100.2, 215.9)
C	VTx1	Tx1 Control Voltage	(110.4, 310.5)
D	VRx2	Rx2 Control Voltage	(90.5, 405.1)
E	VM	Common Receive Control Voltage	(90.5, 499.7)
F	VRx3	Rx3 Control Voltage	(90.5, 594.3)
G	VTx2	Tx2 Control Voltage	(107, 688.9)
H	VRx4	Rx4 Control Voltage	(107, 783.5)
I	Tx2	Tx2 RF Output	(125.9, 878.1)
J	ANT	Antenna	(424.9, 499.7)
K	Rx1	Rx1 RF Output	(568.2, 114.8)
L	GND	Ground	(747.4, 282.7)
M	Rx2	RX2 RF Output	(747.4, 380.3)
N	Rx3	RX3 RF Output	(747.4, 681.2)
O	Rx4	RX4 RF Output	(747.4, 882.1)

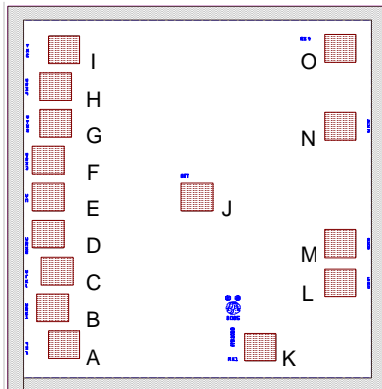
PAD LAYOUT:

Note: Co-ordinates are referenced from the bottom left hand corner of the die to the centre of bond pad opening

DIE SIZE (μm)	DIE THICKNESS (μm)	MIN. BOND PAD PITCH (μm)	MIN. BOND PAD OPENING ($\mu\text{m} \times \mu\text{m}$)
852 x 990	150	94.6	65 x 65

TRUTH TABLE:

VM	VRx4	VRx3	VRx2	VRx1	VTx2	VTx1	ON PATH
Low	Low	Low	Low	Low	Low	High	ANT-TX1
Low	Low	Low	Low	Low	High	Low	ANT-TX2
High	Low	Low	Low	High	Low	Low	ANT-RX1
High	Low	Low	High	Low	Low	Low	ANT-RX2
High	Low	High	Low	Low	Low	Low	ANT-RX3
High	High	Low	Low	Low	Low	Low	ANT-RX4

Note: High: $2.7V \pm 0.2V$; Low: $0V \pm 0.2V$

TYPICAL MEASURED PERFORMANCE ON EVALUATION BOARD:

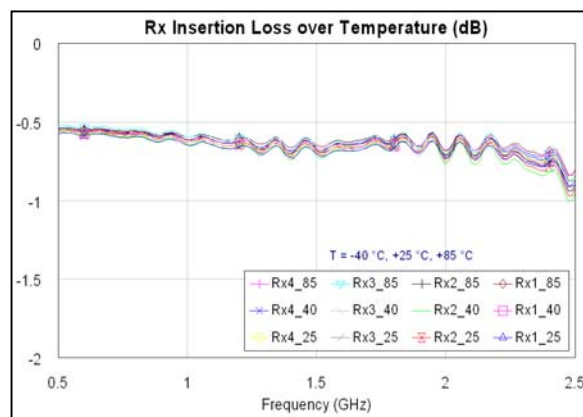
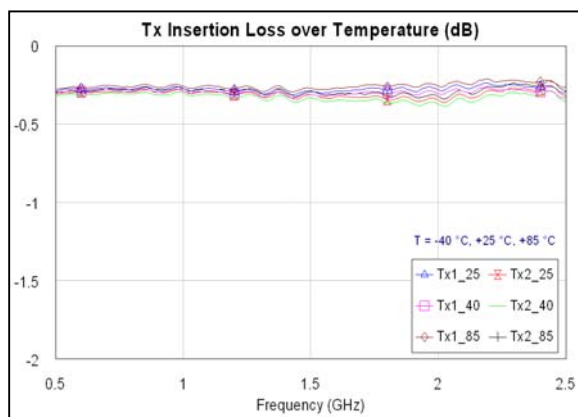
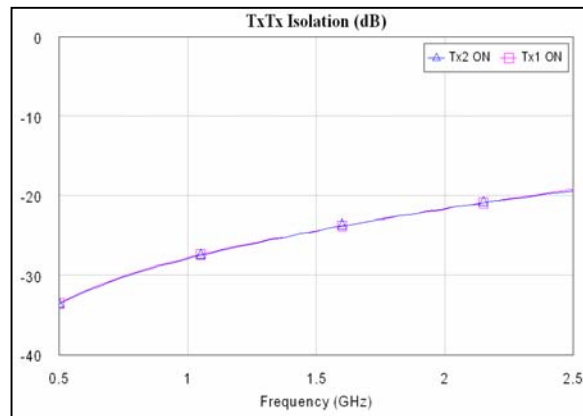
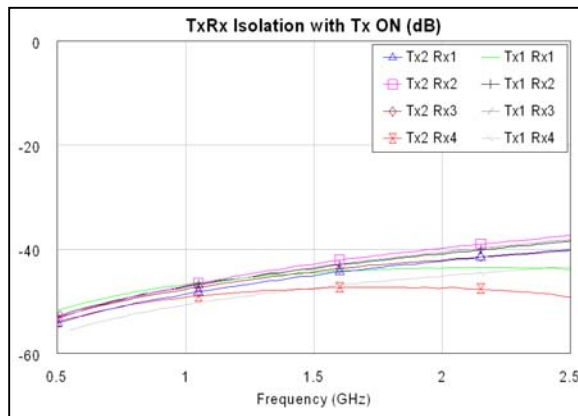
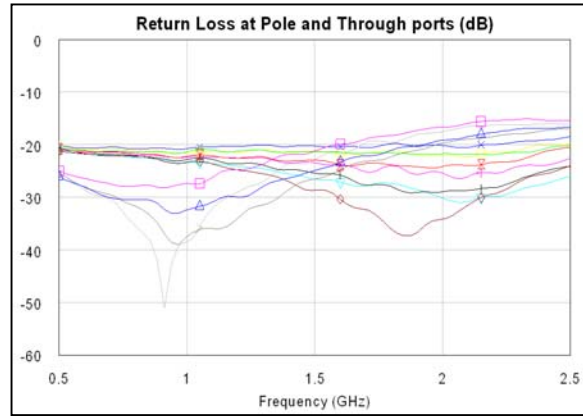
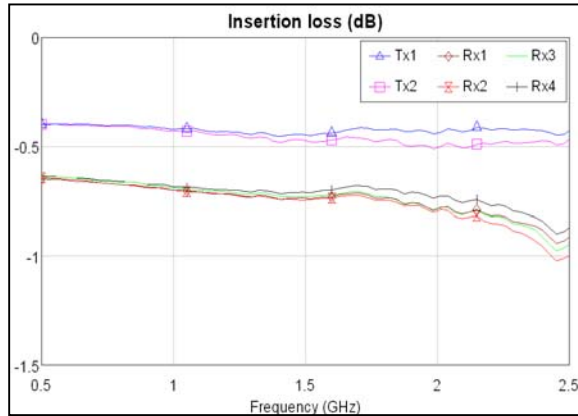
 Note: Measurement Conditions $V_{CTRL} = 0V$ (low) & $2.7V$ (high), $T_{AMBIENT} = 25^{\circ}C$ unless otherwise stated

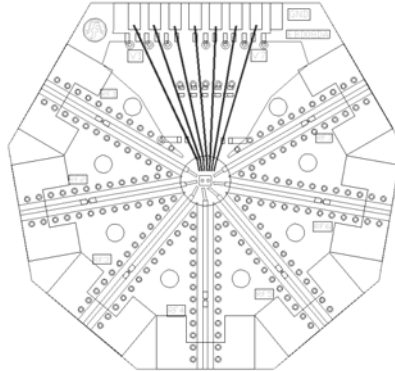
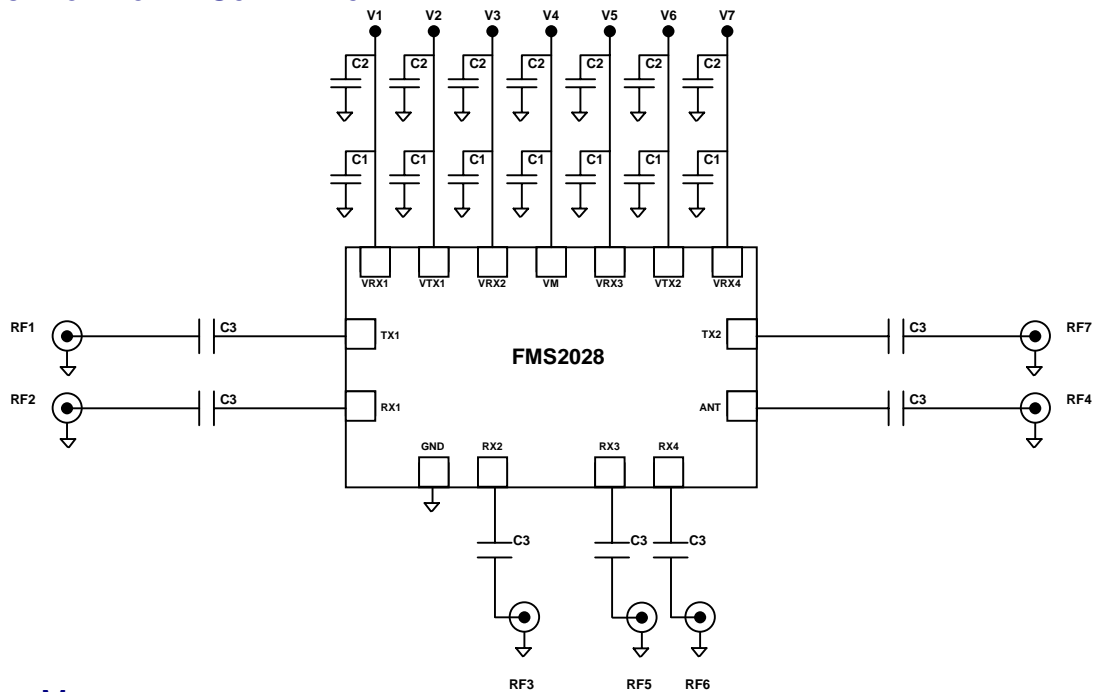
EVALUATION BOARD COMPONENT SIDE LAYOUT:

EVALUATION BOARD SCHEMATIC:

BILL OF MATERIALS:

LABEL	COMPONENT
Board	Preferred evaluation board material is 0.25 mm thick ROGERS RT4350. All RF tracks should be 50 ohm characteristic material.
RFC	SMA RF connector
DCC	DC connector
C1	Capacitor, 47pF, 0402
C2	Capacitor, 470pF, 0603
C3	Capacitor, 100pF, 0402

PREFERRED ASSEMBLY INSTRUCTIONS:

GaAs devices are fragile and should be handled with great care. Specially designed collets should be used where possible.

The back of the die is not metallised and the recommended mounting method is by the use of conductive epoxy. Epoxy is should be applied to the attachment surface uniformly and sparingly to avoid encroachment of epoxy on to the top face of the die and ideally should not exceed half the chip height. For automated dispense Ablestick LMISR4 is recommended and for manual dispense Ablestick 84-1 LMI or 84-1 LMIT are recommended. These should be cured at a temperature of 150°C for 1 hour in an oven especially set aside for epoxy curing only. If possible the curing oven should be flushed with dry nitrogen.

This part has gold (Au) bond pads requiring the use of gold (99.99% pure) bondwire. It is recommended that 25.4µm diameter gold wire is used. Thermosonic ball bonding is preferred. A nominal stage temperature of 150°C and a bonding force of 40g has been shown to give effective results for 25µm wire. Ultrasonic energy shall be kept to a minimum. For this bonding technique, stage temperature should not be raised above 200°C and bond force should not be raised above 60g. Thermosonic wedge bonding and thermocompression wedge bonding can also be used to achieve good wire bonds.

Bonds should be made from the die first and then to the mounting substrate or package. The physical length of the bondwires should be minimised especially when making RF or ground connections.

HANDLING PRECAUTIONS:

To avoid damage to the devices care should be exercised during handling.



Proper Electrostatic Discharge (ESD) precautions should be observed at all stages of storage, handling, assembly, and testing. These devices should be treated as Class 1A (0-500 V) as defined in JEDEC Standard No. 22-A114. Further information on ESD control measures can be found in MIL-STD-1686 and MIL-HDBK-263.

APPLICATION NOTES & DESIGN DATA:

Application Notes and design data including S-parameters, noise data and large-signal models are available on the Filtronic web site.

DISCLAIMERS:

This product is not designed for use in any space based or life sustaining/supporting equipment.

ORDERING INFORMATION:

PART NUMBER	DESCRIPTION
FMS2028-000-FF	Wafer mounted on film frame
FMS2028-000-WP	Die in Waffle-pack (Gel-pak available on request)
FMS2028-000-EB	Die mounted on evaluation board