

SHINDENGEN

Schottky Rectifiers (SBD)

Single

DG1H3

30V 1A

OUTLINE DIMENSIONS

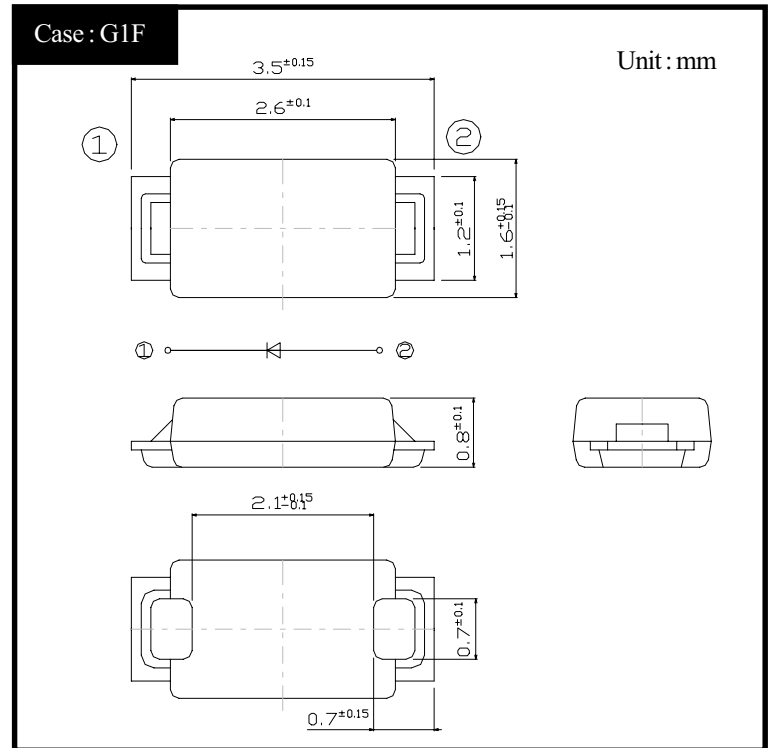

RATINGS

Absolute Maximum Ratings (Tl=25°C unless otherwise specified)

Item	Symbol	Conditions	Ratings	Unit
Storage Temperature	Tstg		-55 to 125	°C
Operating Junction Temperature	Tj		125	°C
Maximum Reverse Voltage	V _{RM}		30	V
Average Rectified Forward Current	I _O	50Hz sine wave, R-load, T _a = 26°C, *1	0.7	A
	I _O	50Hz sine wave, R-load, T _l = 113°C, *3	1.0	A
Peak Surge Forward Current	I _{FSM}	50Hz sine wave, Non-repetitive 1 cycle peak value, T _j =25°C	20	A

Electrical Characteristics (Tl=25°C unless otherwise specified)

Item	Symbol	Conditions	Ratings	Unit
Forward Voltage	V _F	I _F =0.2A, Pulse measurement	Max 0.30	V
	V _F	I _F =0.7A, Pulse measurement	Max 0.36	V
Reverse Current	I _R	V _R =V _{RM} , Pulse measurement	Max 1	mA
Junction Capacitance	C _j	f=1MHz, V _R =10V	Typ 37	pF
Thermal Resistance	θ _{ja}	junction to ambient, *1	Max 210	°C/W
	θ _{ja}	junction to ambient, *2	Max 120	
	θ _{ja}	junction to ambient, *3	Max 70	
	θ _{jl}	junction to lead, *3	Max 20	

*1 Measured on the 1×1 inch phenol substrate (pattern area : 32.6mm²)

*2 Measured on the 1×1 inch phenol substrate (pattern area : 160mm²)

*3 Measured on the 2×2 inch alumina substrate (pattern area : 2100mm²)

DG1H3 Forward Voltage

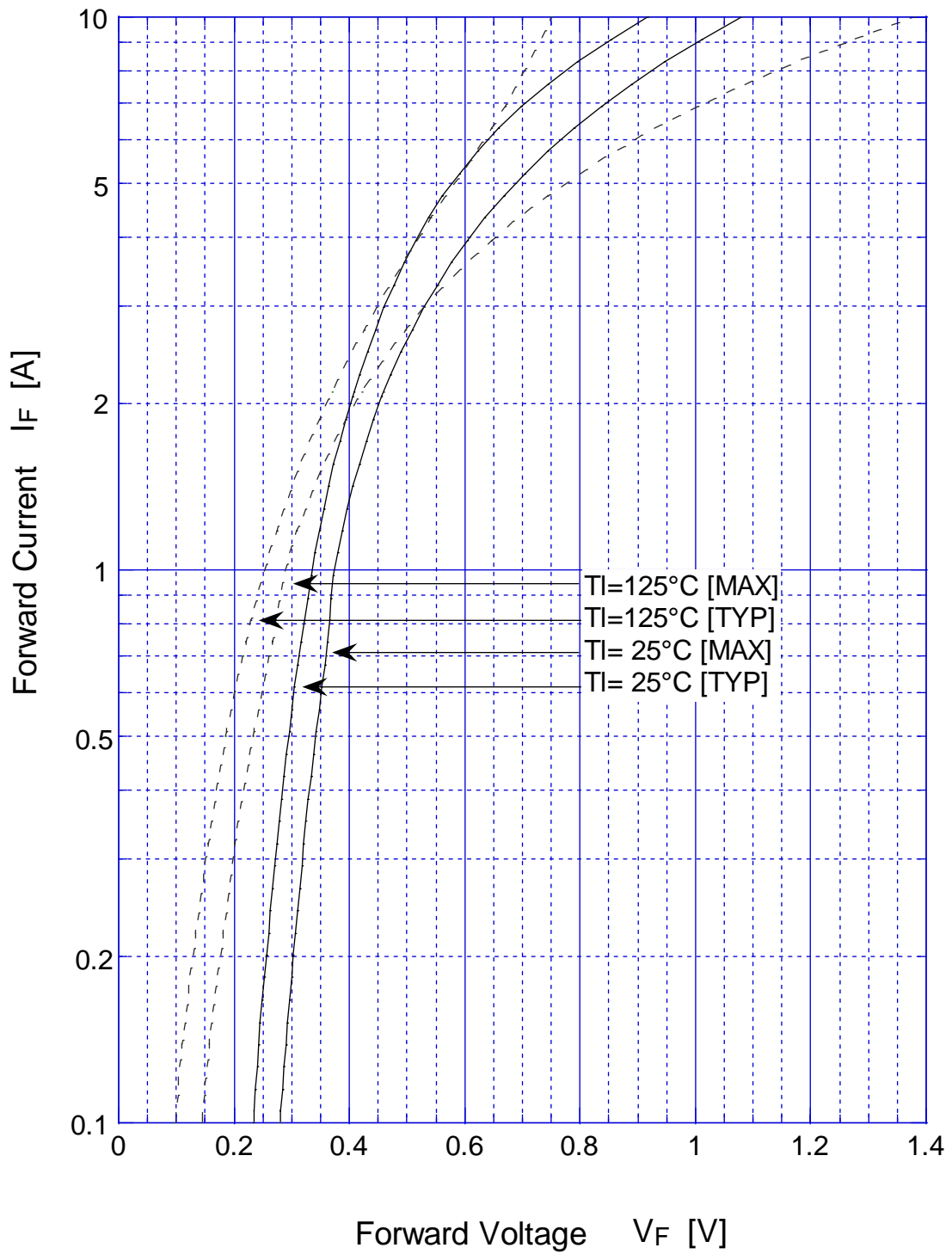

DG1H3 Reverse Current

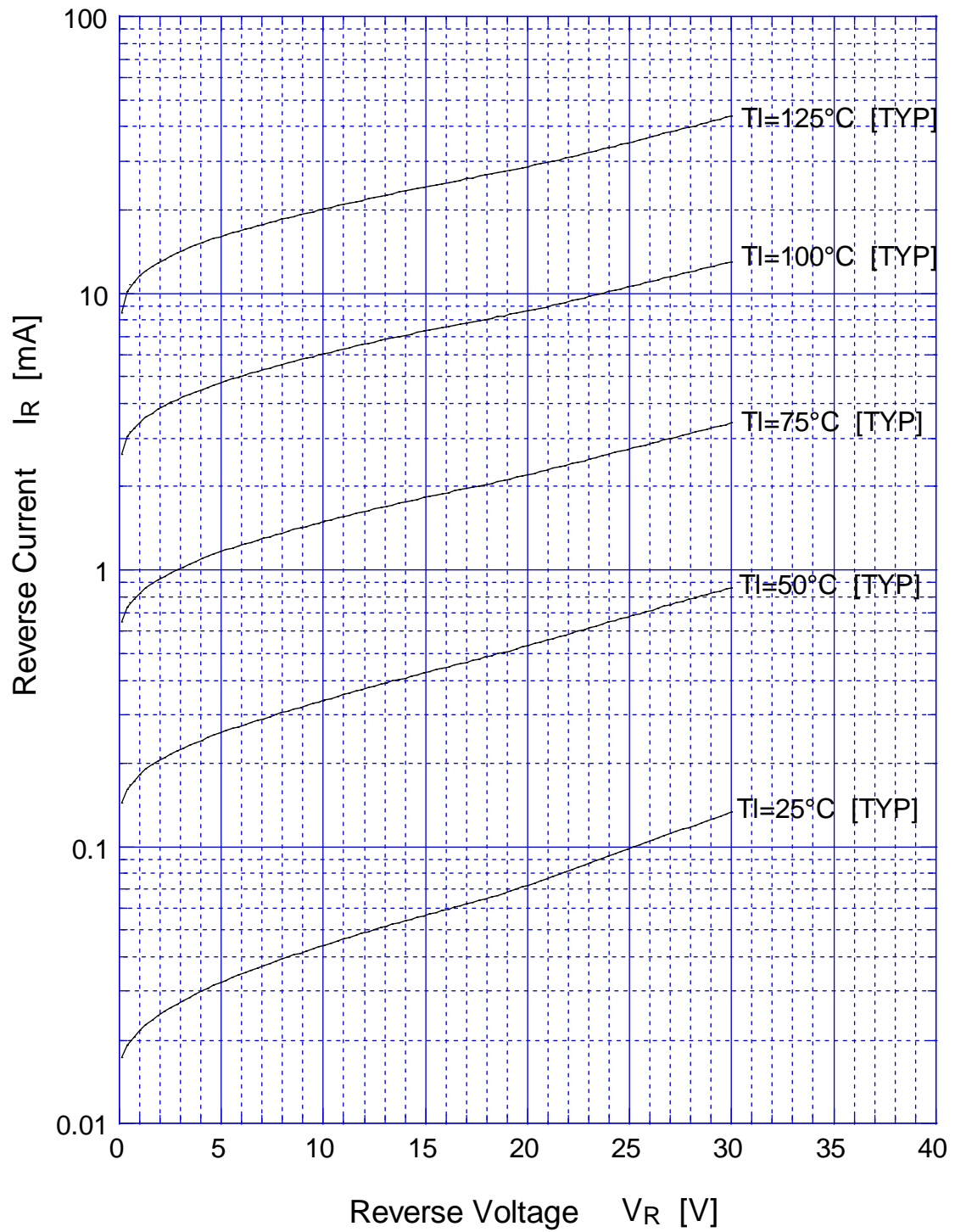

DG1H3 Forward Power Dissipation

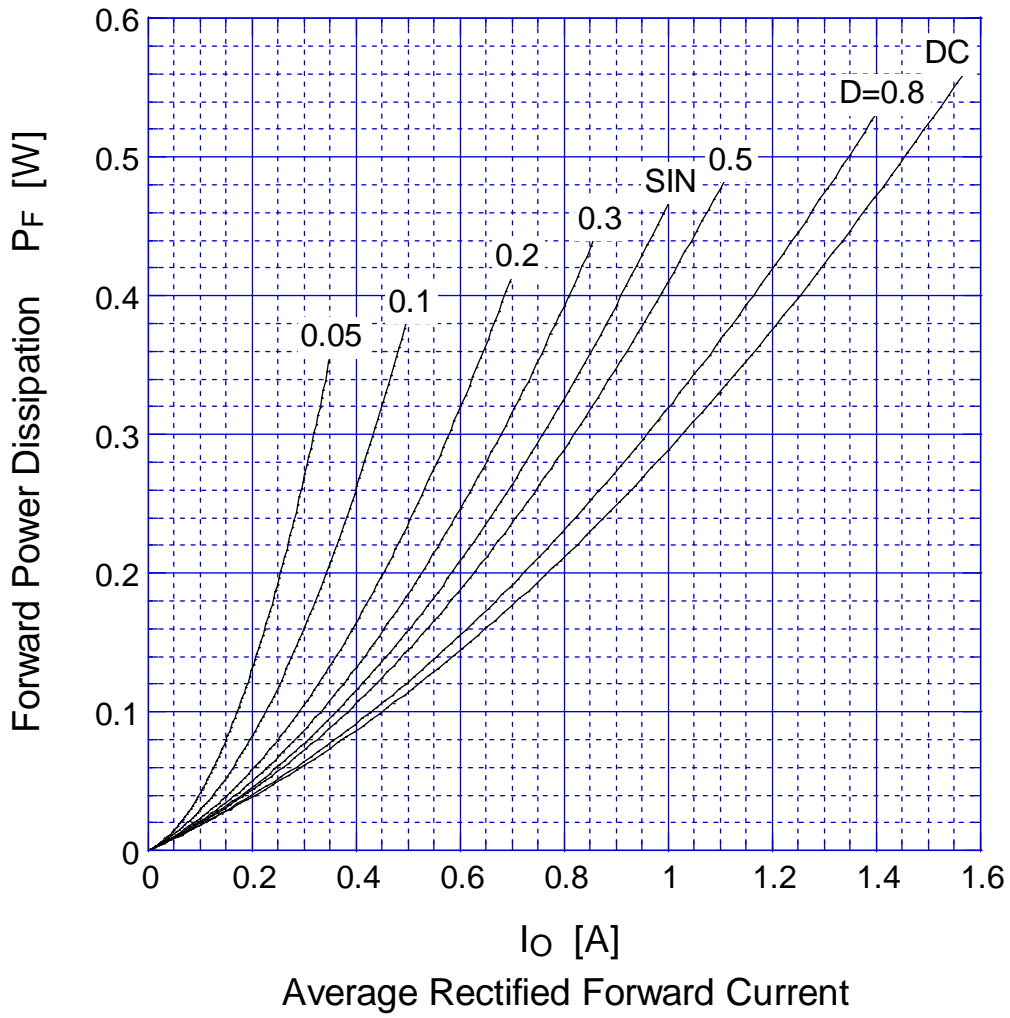

$T_j = 125^\circ\text{C}$

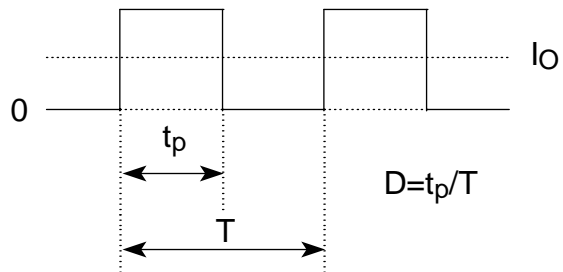

DG1H3 Reverse Power Dissipation

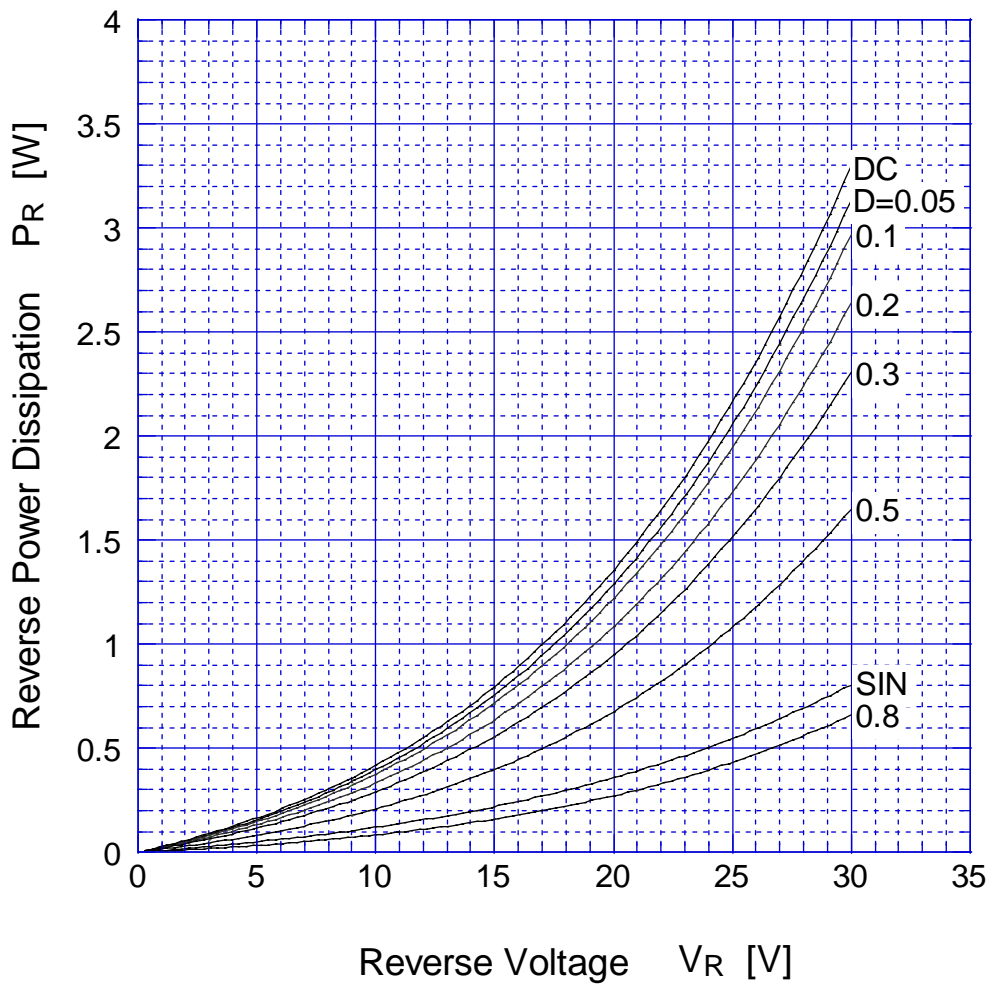

$T_j = 125^\circ\text{C}$

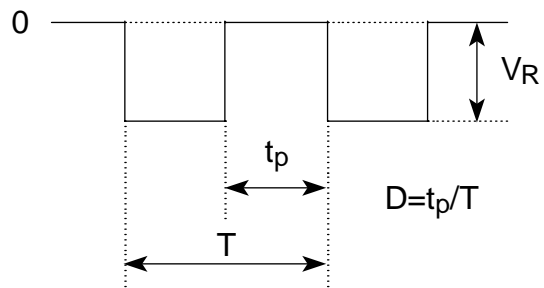

DG1H3

Derating Curve

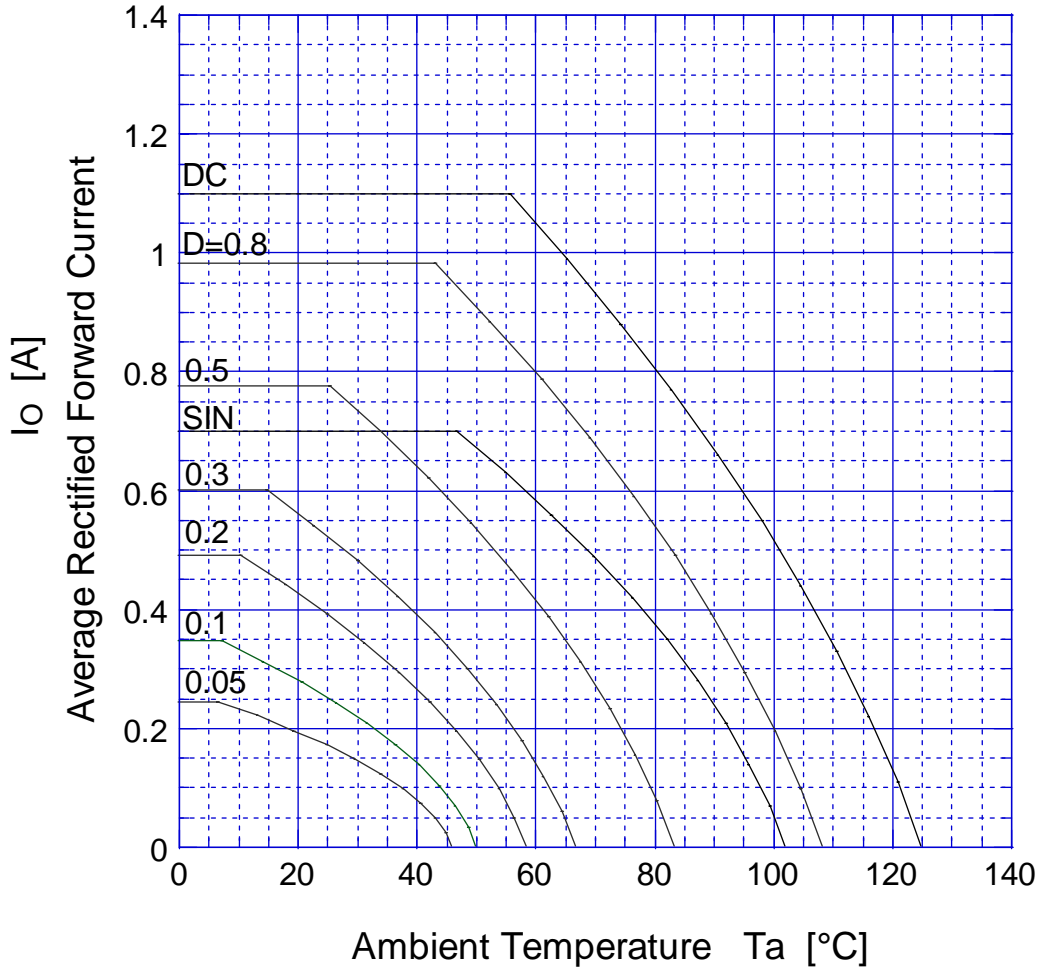

$V_R = 15V$

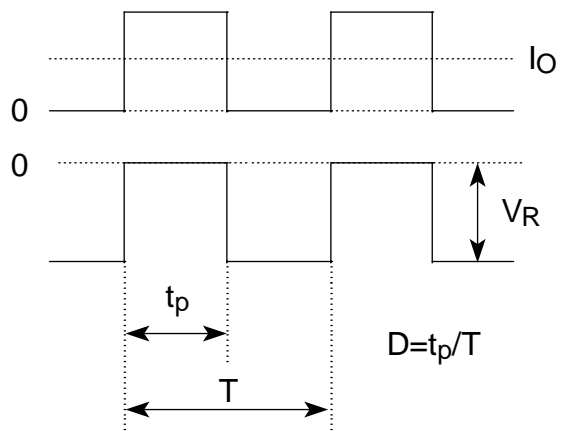
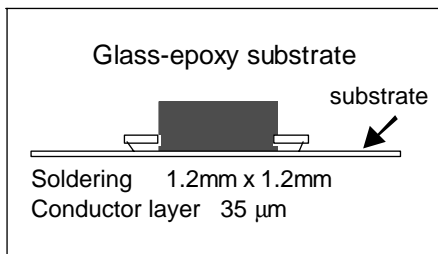

DG1H3

Derating Curve

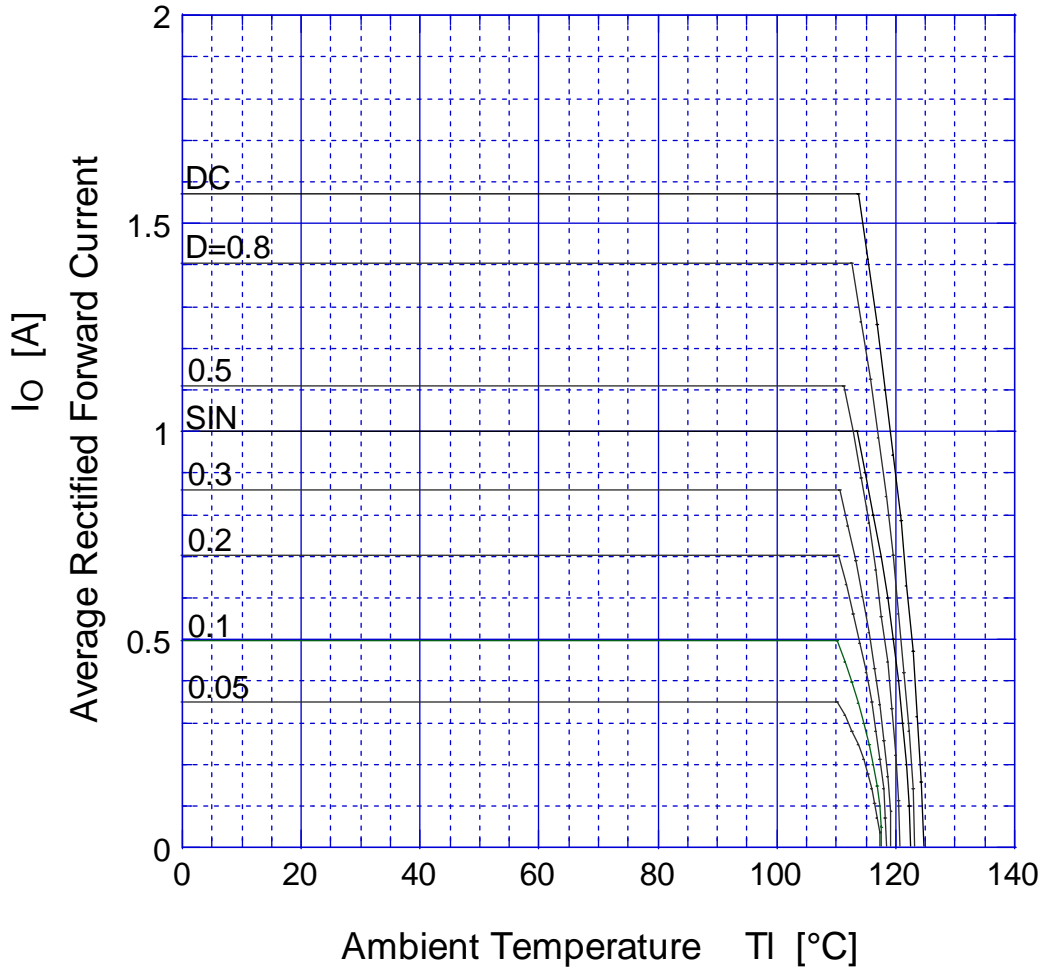

$V_R = 15V$

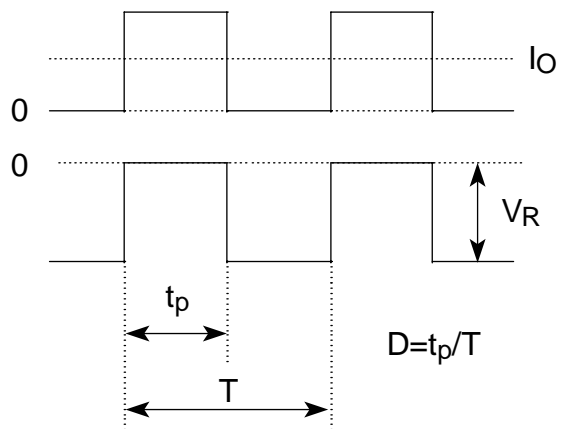
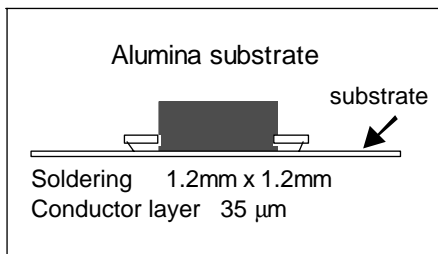

DG1H3 Peak Surge Forward Capability

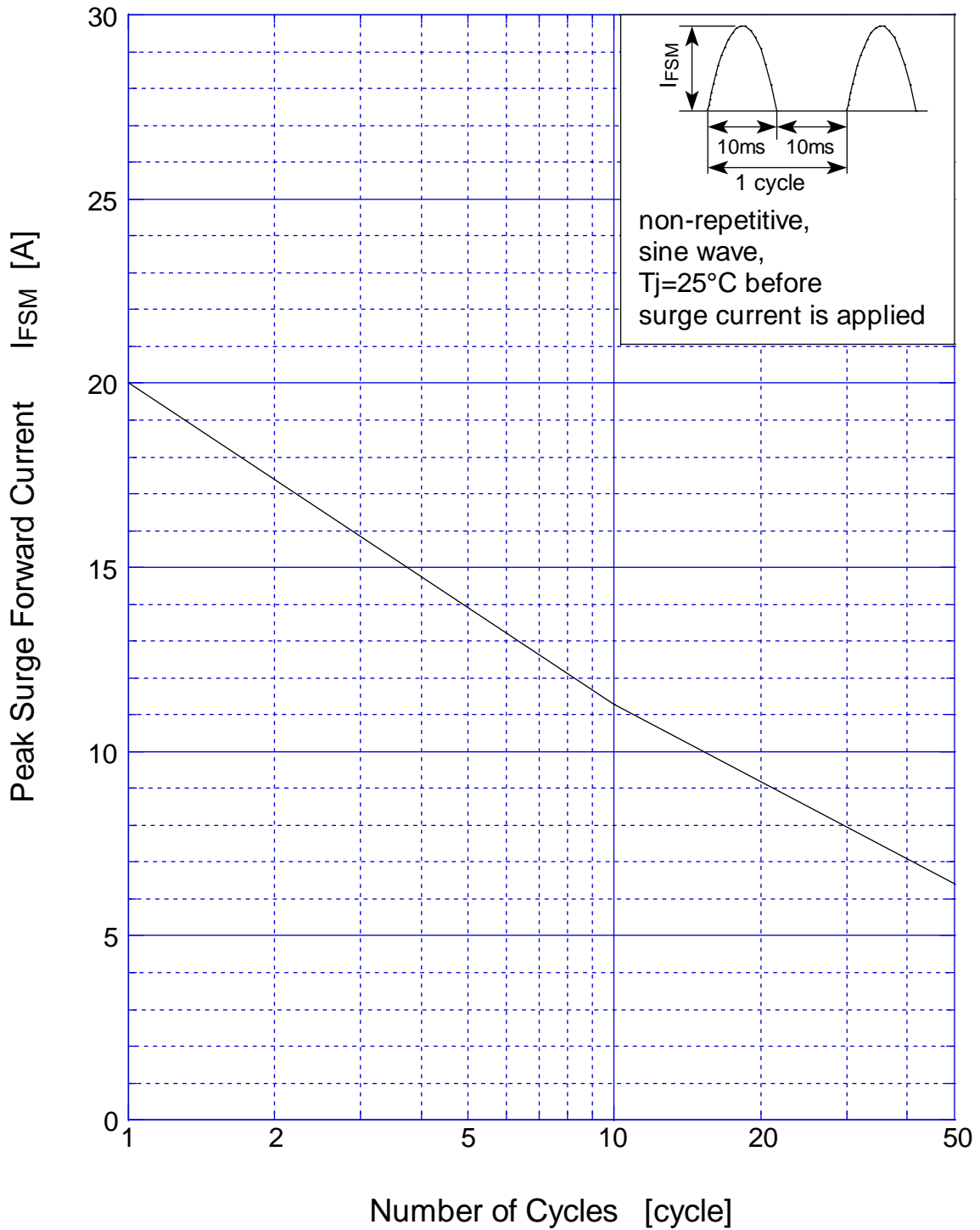

DG1H3 Junction Capacitance

