

COMPLEMENTARY NPN / PNP SMALL SIGNAL SURFACE MOUNT TRANSISTOR

Features

- Complementary Pair
- One 4124-Type NPN, One 4126-Type PNP
- Epitaxial Planar Die Construction
- Ideal for Medium Power Amplification and Switching
- Ultra-Small Surface Mount Package
- **Lead Free/RoHS Compliant (Note 3)**

Mechanical Data

- Case: SOT-363
- Case Material: Molded Plastic. UL Flammability Classification Rating 94V-0
- Moisture Sensitivity: Level 1 per J-STD-020C
- Terminals: Solderable per MIL-STD-202, Method 208
- Lead Free Plating (Matte Tin Finish annealed over Alloy 42).
- Terminal Connections: See Diagram
- Marking (See Page 3): K12
- Ordering & Date Code Information: See Pages 2 & 3
- Weight: 0.006 grams (approx.)

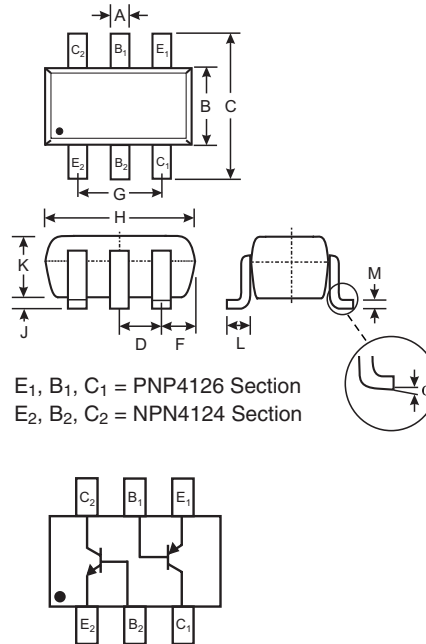

SOT-363		
Dim	Min	Max
A	0.10	0.30
B	1.15	1.35
C	2.00	2.20
D	0.65 Nominal	
F	0.30	0.40
H	1.80	2.20
J	—	0.10
K	0.90	1.00
L	0.25	0.40
M	0.10	0.25
α	0°	8°
All Dimensions in mm		

Maximum Ratings, NPN 4124 Section @ $T_A = 25^\circ\text{C}$ unless otherwise specified

Characteristic	Symbol	NPN 4124 Section	Unit
Collector-Base Voltage	V_{CBO}	30	V
Collector-Emitter Voltage	V_{CEO}	25	V
Emitter-Base Voltage	V_{EBO}	5.0	V
Collector Current - Continuous (Note 1)	I_C	200	mA
Power Dissipation (Note 1, 2)	P_d	200	mW
Thermal Resistance, Junction to Ambient (Note 1)	$R_{\theta JA}$	625	$^\circ\text{C/W}$

Maximum Ratings, PNP 4126 Section @ $T_A = 25^\circ\text{C}$ unless otherwise specified

Characteristic	Symbol	PNP 4126 Section	Unit
Collector-Base Voltage	V_{CBO}	-25	V
Collector-Emitter Voltage	V_{CEO}	-25	V
Emitter-Base Voltage	V_{EBO}	-4	V
Collector Current - Continuous (Note 1)	I_C	-200	mA
Power Dissipation (Note 1, 2)	P_d	200	mW
Thermal Resistance, Junction to Ambient (Note 1)	$R_{\theta JA}$	625	$^\circ\text{C/W}$

- Notes:
1. Device mounted on FR-4 PCB, 1 inch x 0.85 inch x 0.062 inch; pad layout as shown on Diodes Inc. suggested pad layout document AP02001, which can be found on our website at <http://www.diodes.com/datasheets/ap02001.pdf>.
 2. Maximum combined dissipation.
 3. No purposefully added lead.

Electrical Characteristics, NPN 4124 Section

@ T_A = 25°C unless otherwise specified

Characteristic	Symbol	Min	Max	Unit	Test Condition
OFF CHARACTERISTICS (Note 4)					
Collector-Base Breakdown Voltage	V _{(BR)CBO}	30	—	V	I _C = 10μA, I _E = 0
Collector-Emitter Breakdown Voltage	V _{(BR)CEO}	25	—	V	I _C = 1.0mA, I _B = 0
Emitter-Base Breakdown Voltage	V _{(BR)EBO}	5.0	6.0	V	I _E = 10μA, I _C = 0
Collector Cutoff Current	I _{CBO}	—	50	nA	V _{CB} = 20V, I _E = 0V
Emitter Cutoff Current	I _{EBO}	—	50	nA	V _{EB} = 3.0V, I _C = 0V
ON CHARACTERISTICS (Note 4)					
DC Current Gain	h _{FE}	120 60	360 —	—	I _C = 2.0mA, V _{CE} = 1.0V I _C = 50mA, V _{CE} = 1.0V
Collector-Emitter Saturation Voltage	V _{CE(SAT)}	—	0.30	V	I _C = 50mA, I _B = 5.0mA
Base-Emitter Saturation Voltage	V _{BE(SAT)}	—	0.95	V	I _C = 50mA, I _B = 5.0mA
SMALL SIGNAL CHARACTERISTICS					
Output Capacitance	C _{obo}	—	4.0	pF	V _{CB} = 5.0V, f = 1.0MHz, I _E = 0
Input Capacitance	C _{ibo}	—	8.0	pF	V _{EB} = 0.5V, f = 1.0MHz, I _C = 0
Small Signal Current Gain	h _{fe}	120	480	—	V _{CE} = 1.0V, I _C = 2.0mA, f = 1.0kHz
Current Gain-Bandwidth Product	f _T	300	—	MHz	V _{CE} = 20V, I _C = 10mA, f = 100MHz

Electrical Characteristics, PNP 4126 Section

@ T_A = 25°C unless otherwise specified

Characteristic	Symbol	Min	Max	Unit	Test Condition
OFF CHARACTERISTICS (Note 4)					
Collector-Base Breakdown Voltage	V _{(BR)CBO}	-25	—	V	I _C = -10μA, I _E = 0
Collector-Emitter Breakdown Voltage	V _{(BR)CEO}	-25	—	V	I _C = -1.0mA, I _B = 0
Emitter-Base Breakdown Voltage	V _{(BR)EBO}	-4.0	—	V	I _E = -10μA, I _C = 0
Collector Cutoff Current	I _{CBO}	—	-50	nA	V _{CB} = -20V, I _E = 0V
Emitter Cutoff Current	I _{EBO}	—	-50	nA	V _{EB} = -3.0V, I _C = 0V
ON CHARACTERISTICS (Note 4)					
DC Current Gain	h _{FE}	120 60	360 —	—	I _C = -2.0mA, V _{CE} = -1.0V I _C = -50mA, V _{CE} = -1.0V
Collector-Emitter Saturation Voltage	V _{CE(SAT)}	—	-0.40	V	I _C = -50mA, I _B = -5.0mA
Base-Emitter Saturation Voltage	V _{BE(SAT)}	—	-0.95	V	I _C = -50mA, I _B = -5.0mA
SMALL SIGNAL CHARACTERISTICS					
Output Capacitance	C _{obo}	—	4.5	pF	V _{CB} = -5.0V, f = 1.0MHz, I _E = 0
Input Capacitance	C _{ibo}	—	10	pF	V _{EB} = -0.5V, f = 1.0MHz, I _C = 0
Small Signal Current Gain	h _{fe}	120	480	—	V _{CE} = -1.0V, I _C = -2.0mA, f = 1.0kHz
Current Gain-Bandwidth Product	f _T	250	—	MHz	V _{CE} = -20V, I _C = -10mA, f = 100MHz
Noise Figure	NF	—	4.0	dB	V _{CE} = -5.0V, I _C = -100μA, R _S = 1.0kΩ, f = 1.0kHz

Ordering Information (Note 5)

Device	Packaging	Shipping
MMDT4146-7-F	SOT-363	3000/Tape & Reel

- Notes: 4. Short duration test pulse used to minimize self-heating effect.
5. For Packaging Details, go to our website at <http://www.diodes.com/datasheets/ap02007.pdf>.

Marking Information

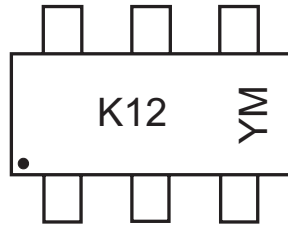

K12= Product Type Marking Code
 YM = Date Code Marking
 Y = Year ex: N = 2002
 M = Month ex: 9 = September

Date Code Key

Year	1998	1999	2000	2001	2002	2003	2004	2005	2006	2007	2008	2009
Code	J	K	L	M	N	P	R	S	T	U	V	W

Month	Jan	Feb	March	Apr	May	Jun	Jul	Aug	Sep	Oct	Nov	Dec
Code	1	2	3	4	5	6	7	8	9	O	N	D

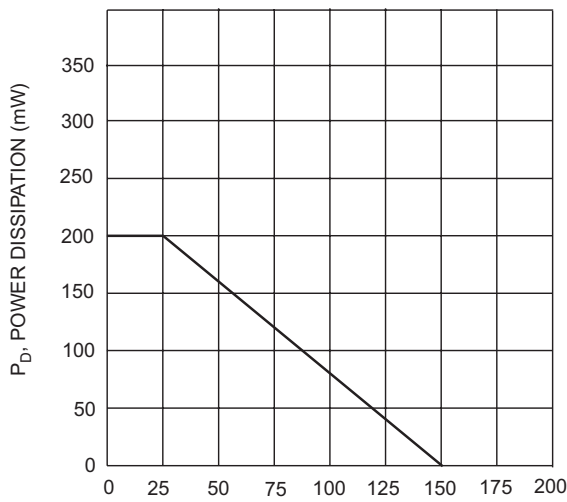

T_A , AMBIENT TEMPERATURE (°C)
 Fig. 1, Max Power Dissipation vs Ambient Temperature (Total Device)

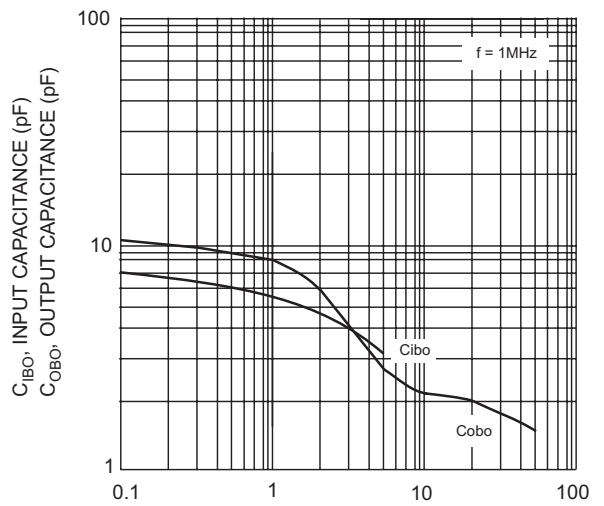

V_{CB} , COLLECTOR-BASE VOLTAGE (V)
 Fig. 2, Input and Output Capacitance vs. Collector-Base Voltage (PNP-4126)

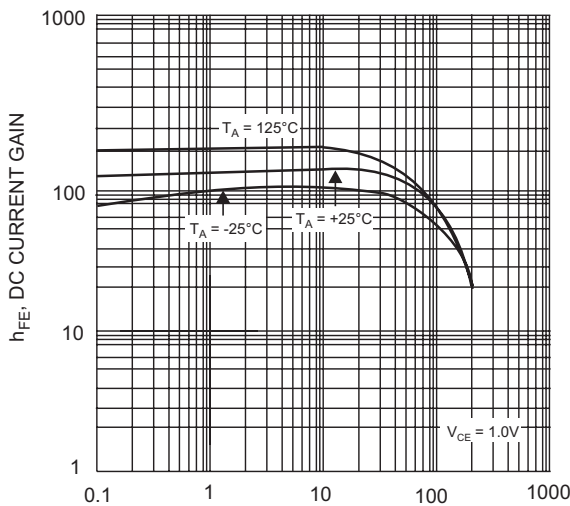

I_C , COLLECTOR CURRENT (mA)
 Fig. 3, Typical DC Current Gain vs Collector Current (PNP-4126)

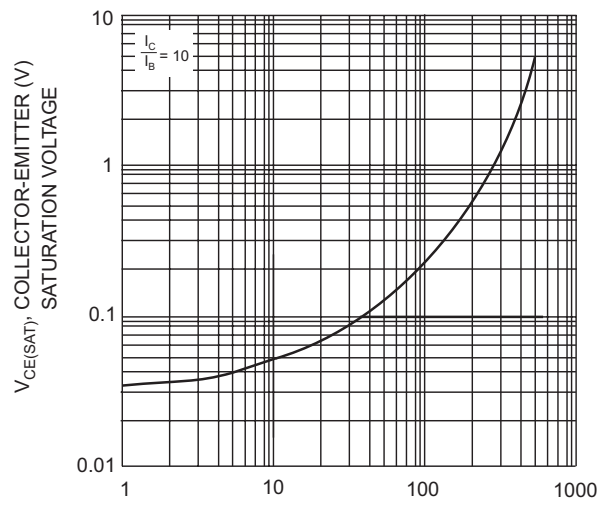

I_C , COLLECTOR CURRENT (mA)
 Fig. 4, Typical Collector-Emitter Saturation Voltage vs. Collector Current (PNP-4126)

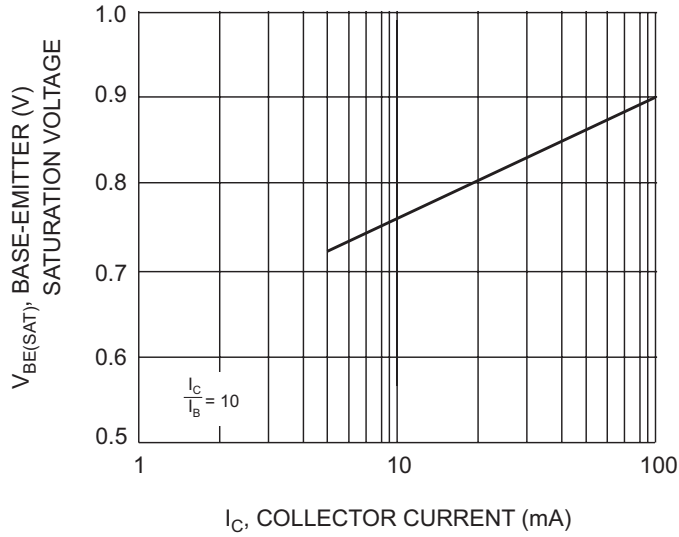

I_C , COLLECTOR CURRENT (mA)
Fig. 5, Typical Base-Emitter Saturation Voltage vs. Collector Current (PNP-4126)

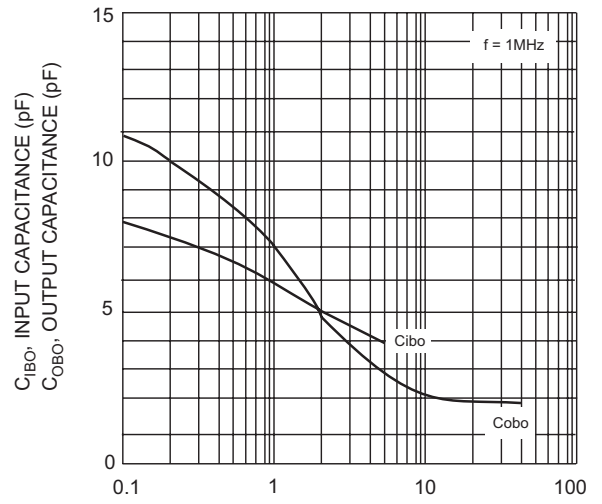

V_{CB} , COLLECTOR-BASE VOLTAGE (V)
Fig. 6, Input and Output Capacitance vs. Collector-Base Voltage (NPN-4124)

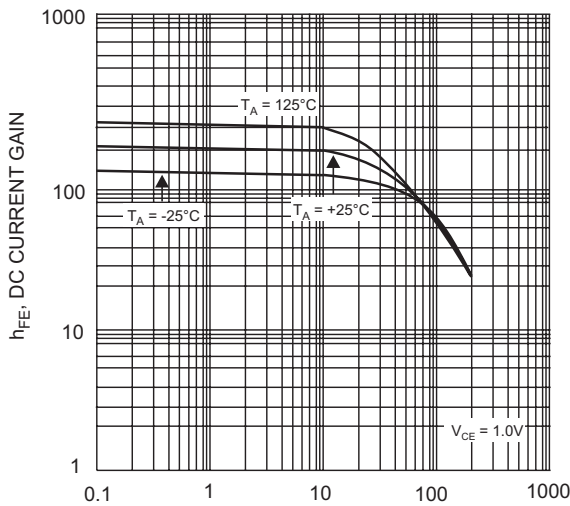

I_C , COLLECTOR CURRENT (mA)
Fig. 7, Typical DC Current Gain vs. Collector Current (NPN-4124)

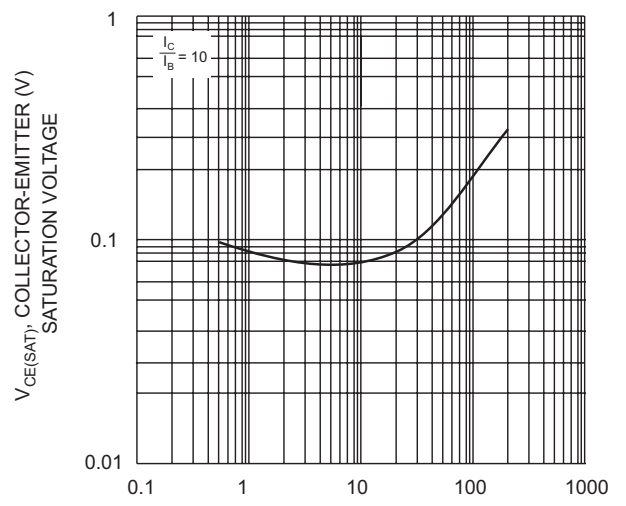

I_C , COLLECTOR CURRENT (mA)
Fig. 8, Typical Collector-Emitter Saturation Voltage vs. Collector Current (NPN-4124)

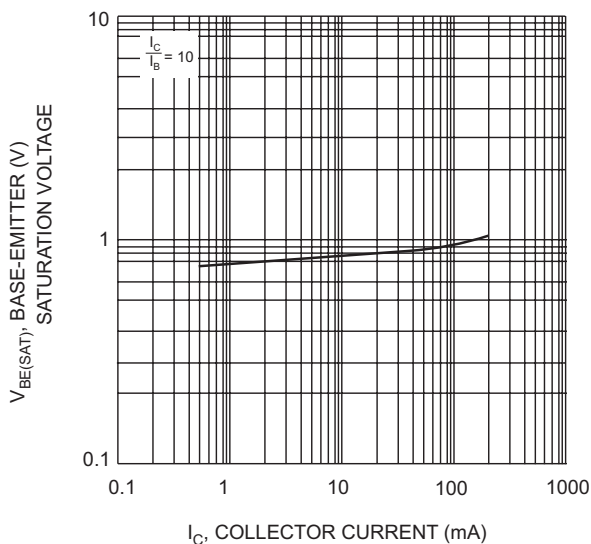

I_C , COLLECTOR CURRENT (mA)
Fig. 9, Typical Base-Emitter Saturation Voltage vs. Collector Current (NPN-4124)

IMPORTANT NOTICE

Diodes, Inc. and its subsidiaries reserve the right to make changes without further notice to any product herein to make corrections, modifications, enhancements, improvements, or other changes. Diodes, Inc. does not assume any liability arising out of the application or use of any product described herein; neither does it convey any license under its patent rights, nor the rights of others. The user of products in such applications shall assume all risks of such use and will agree to hold Diodes Incorporated and all the companies whose products are represented on our website, harmless against all damages.

LIFE SUPPORT

The products located on our website at www.diodes.com are not recommended for use in life support systems where a failure or malfunction of the component may directly threaten life or cause injury without the express written approval of Diodes Incorporated.