

### Features

- Diffused Junction
- Low Reverse Leakage Current
- Low Power Loss, High Efficiency
- Surge Overload Rating to 400A Peak
- Electrically Isolated Metal Case for Maximum Heat Dissipation
- High Case Dielectric Strength of 1500V<sub>RMS</sub>

### Mechanical Data

- Case : High Conductivity Metal
- Terminals : Plated Leads Solderable per MIL-STD-202, Method 208
- Polarity : Symbols Marked on Case
- Mounting : Through Hole for #10 Screw
- Mounting Torque : 8.0 Inch-pounds Maximum
- Weight : KBPC 31.6 grams (approx.)  
KBPC-W 28.5 grams (approx.)
- Mounting Position : Any
- Marking : Type Number

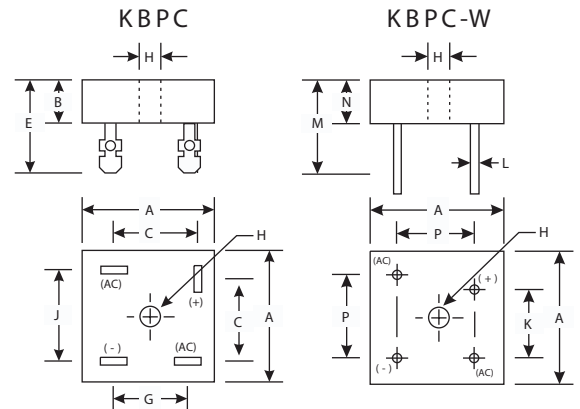

KBPC / KBPC-W					
Dim	Min	Max	Dim	Min	Max
A	28.40	28.70	J	17.10	19.10
B	10.97	11.23	K	10.40	12.40
C	15.50	17.60	L	0.97 $\phi$	1.07 $\phi$
E	22.86	25.40	M	30.50	—
G	13.30	15.30	N	10.97	11.23
H	Hole for #10 screw		P	17.10	19.10
	4.85 $\phi$	5.59 $\phi$			

All Dimensions in mm  
"W" Suffix Designates Wire Leads  
No Suffix Designates Fast-on Terminals

### Maximum Ratings And Electrical Characteristics

(Ratings at 25 °C ambient temperature unless otherwise specified, Single phase, half wave 60Hz, resistive or inductive load. For capacitive load, derate by 20%)

	Symbols	KBPC40005/W	KBPC4001/W	KBPC4002/W	KBPC4004/W	KBPC4006/W	KBPC4008/W	KBPC4010/W	Units
Peak Repetitive Reverse voltage	$V_{RMM}$								Volts
Working Peak Reverse voltage	$V_{RWM}$	50	100	200	400	600	800	1000	Volts
DC Blocking voltage	$V_R$								Volts
RMS Reverse voltage	$V_{R(RMS)}$	35	70	140	280	420	560	700	Volts
Average Rectified Output Current @ $T_c=55^\circ C$	$I_o$	40							Amps
Non-Repetitive Peak Forward Surge Current, 8.3ms single half-sine-wave superimposed on rated load (JEDEC method)	$I_{FSM}$	500							Amps
Forward voltage (per element) @ $I_F=20 A$	$V_{FM}$	1.2							Volts
Peak Reverse Current at Rated DC Blocking voltage	@ $T_c=25^\circ C$	10							$\mu A$
	@ $T_c=125^\circ C$	1.0							mA
$I^2t$ Rating for Fusing ( $t < 8.3ms$ ) (Note 2)	$I^2t$	800							$A^2s$
Typical Junction Capacitance (Note 3)	$C_j$	300							pF
Typical Thermal Resistance Junction to Case	$R\theta_{JA}$	1.5							$^\circ C/W$
Operating and Storage Temperature Range	$T_j$ $T_{STG}$	-50 to +150							$^\circ C$

#### Notes:

- (1) Thermal resistance junction to case mounted on heat sink.
- (2) Measured at non-repetitive, for  $t > 1.0ms$  and  $< 8.3ms$ .
- (3) Measured at 1.0MHz and applied reverse voltage of 4.0V DC.

## RATINGS AND CHARACTERISTIC CURVES KBPC40005/W THRU KBPC4010/W

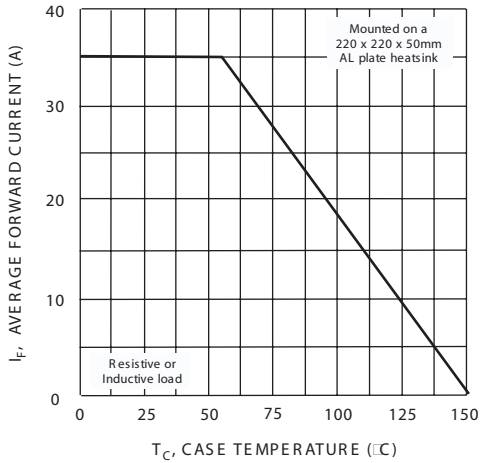

Fig. 1 Forward Current Derating Curve.

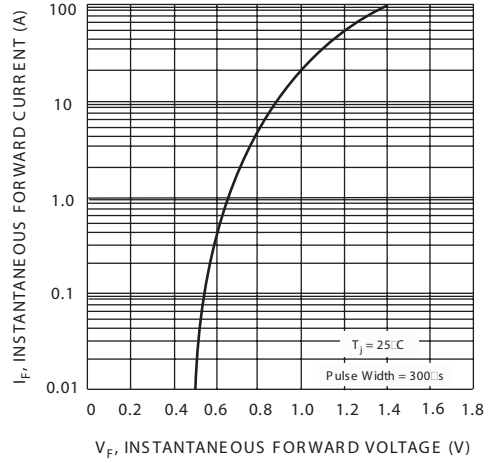

Fig. 2 Typical Forward Characteristics (per element)

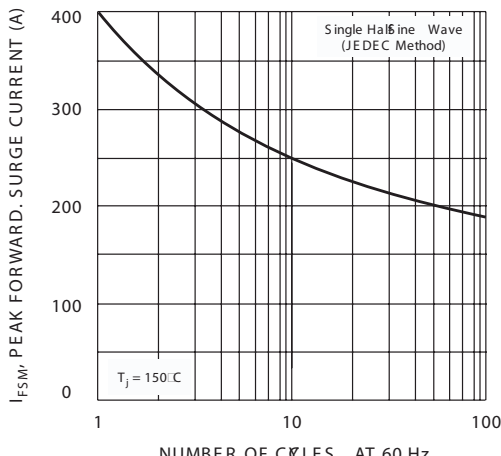

Fig. 3 Maximum NonRepetitive Surge Current

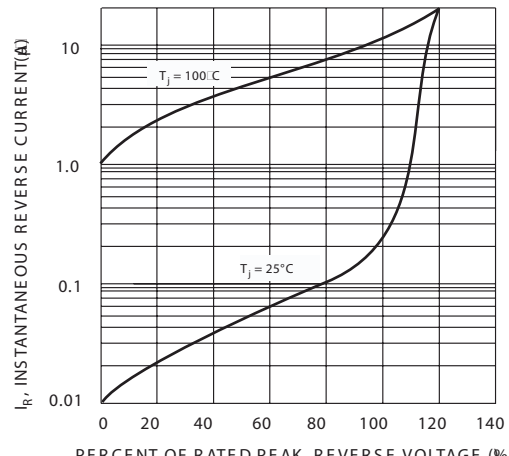

Fig. 4 Typical Reverse Characteristics (per element)