

**Magneto-Resistance Element**

**Description**

The DM-111A is a highly sensitive magnetic resistance element, composed of an evaporated ferromagnetic alloy on a silicon substrate. The element can be used for detection of rotational speed and for detection of angle of rotation and as a detection of position.

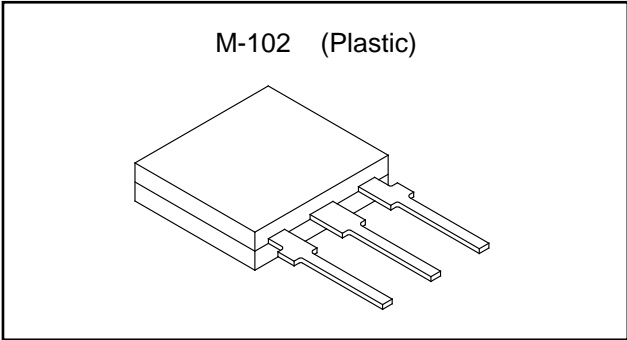

**Features**

- Low power consumption  
38 $\mu$ W (Typ.) at  $V_{cc}=5V$
- Low magnetic field and high sensitivity  
75mVp-p (Typ.) at  $V_{cc}=5V$   
and  $H=4000A/m$
- High reliability  
Ensured through silicon nitride protective filming

**Absolute Maximum Ratings (Ta=25°C)**

- Supply voltage  $V_{cc}$  10 V
- Operating temperature  $T_{opr}$  -40 to +80 °C
- Storage temperature  $T_{stg}$  -50 to +100 °C

**Recommended Operating Condition** 5 V

**Electrical Characteristics**

(Ta=25°C)

Item	Symbol	Condition	Min.	Typ.	Max.	Unit
Total resistance	$R_T$	$H=4000A/m, \theta=45^\circ$	500	650	800	k $\Omega$
Midpoint potential	$V_c$	$V_{cc}=5V, H=4000A/m$ Revoiving magnetic field	2.47	2.50	2.53	V
Output voltage	$V_o$	$V_{cc}=5V, H=4000A/m$ Revoiving magnetic field	30	75		mVp-p

Sony reserves the right to change products and specifications without prior notice. This information does not convey any license by any implication or otherwise under any patents or other right. Application circuits shown, if any, are typical examples illustrating the operation of the devices. Sony cannot assume responsibility for any problems arising out of the use of these circuits.

Equivalent Circuit

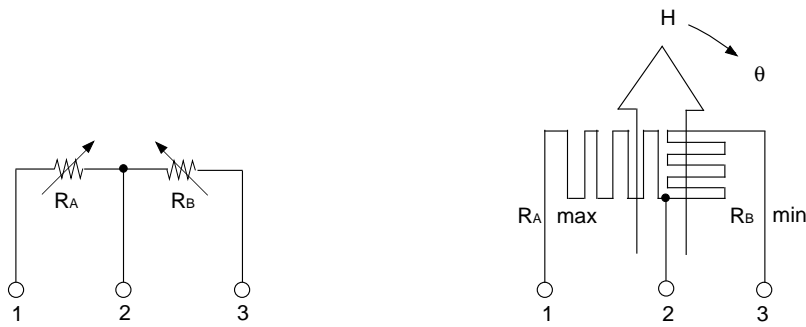

$R_A$  : Resistance reduces as the magnetic field revolves.  
 $R_B$  : Resistance increases as the magnetic field revolves.

Introduction

1) Power supplying pin output pin

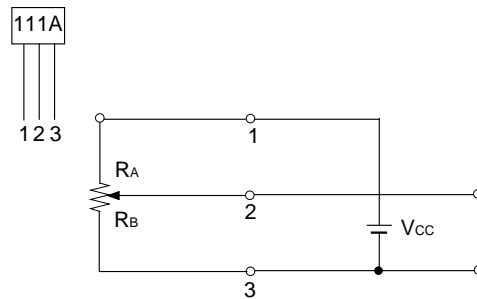

2) Sensitive direction vs. Midpoint potential

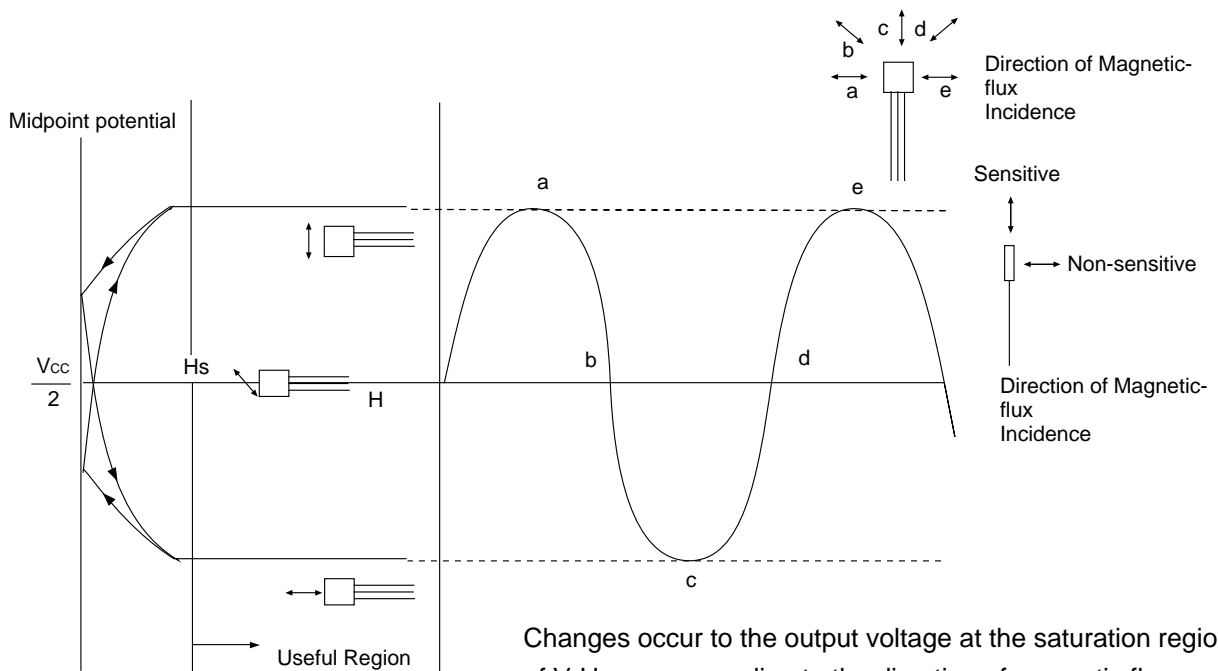

Changes occur to the output voltage at the saturation region of V-H curve according to the direction of magnetic flux. These changes provide for the operation.

- With one rotation of magnetic flux, signals for 2 periods are obtained.

3) 0° Biasing magnetic field  
(Switching use)

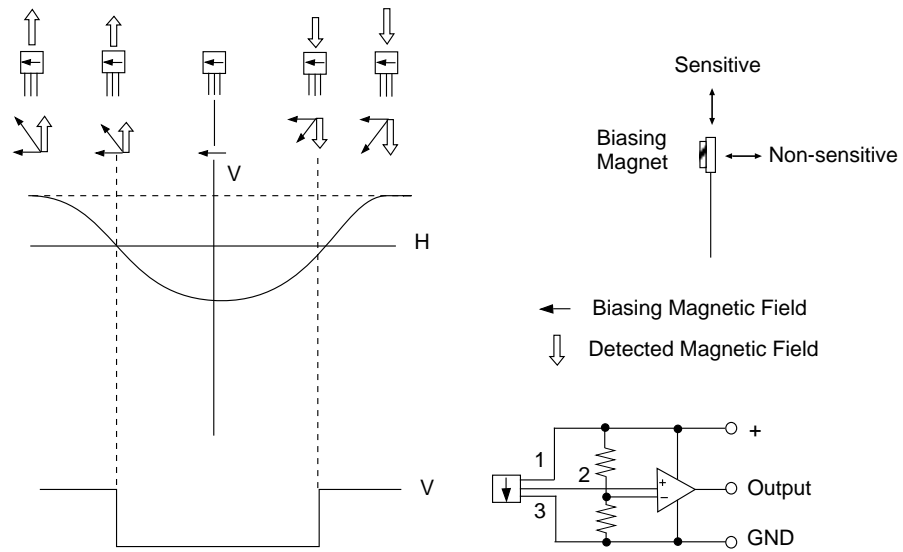

4) 45° Biasing magnetic field  
(Analog use)

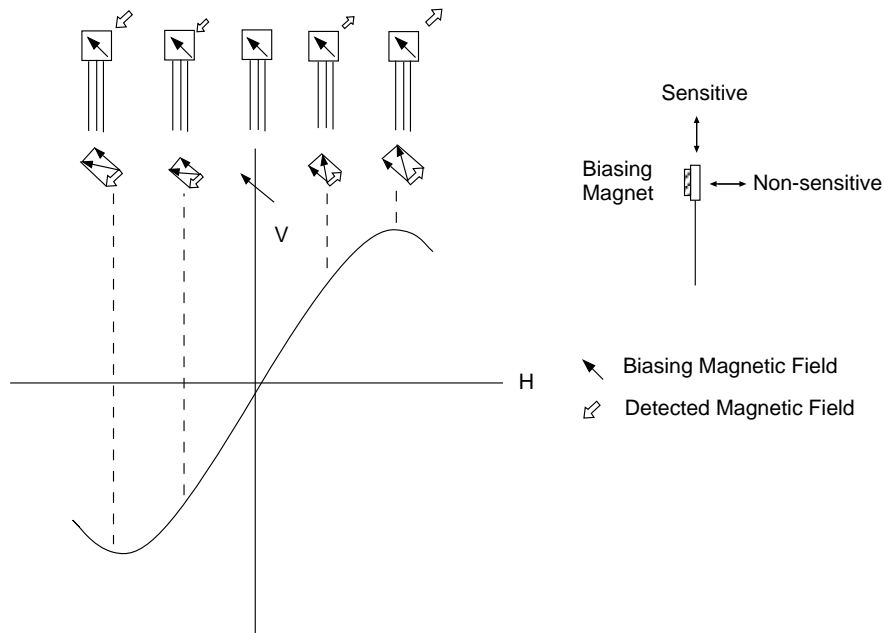

**Applications**

1. Detection of revolution

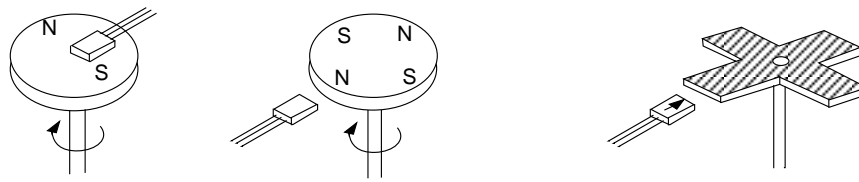

2. Position detecting

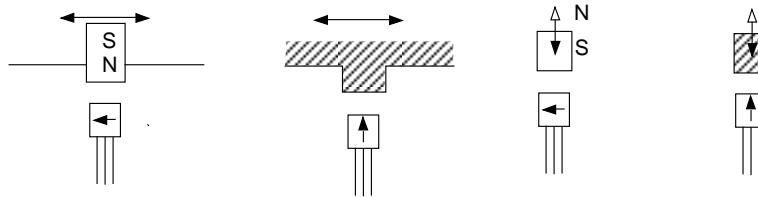

3. Angular detection of rotating wheel

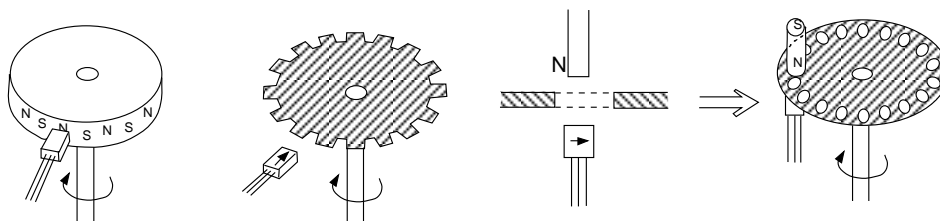

4. Reading out of analog value

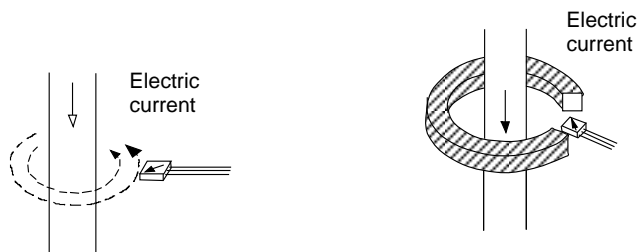

5. Position detecting of revolving element

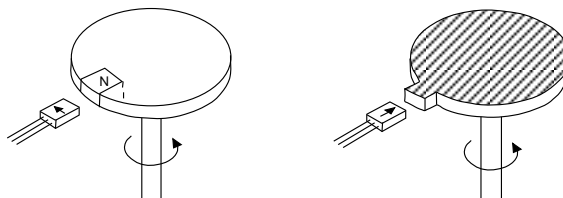

 Magnetic conductors

Circuits

2), 3), 5)

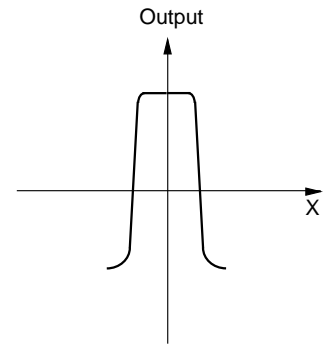
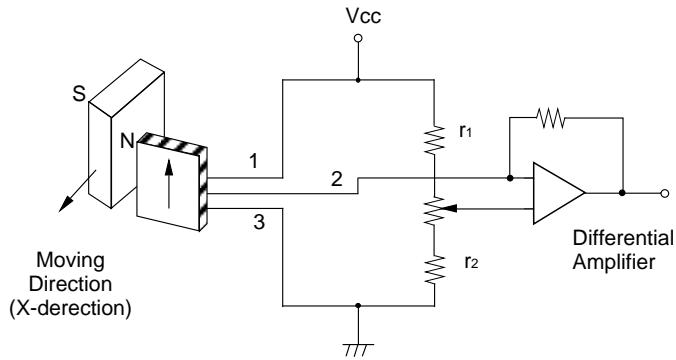

1), 2), 3), 5)

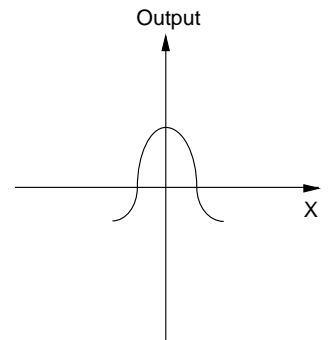
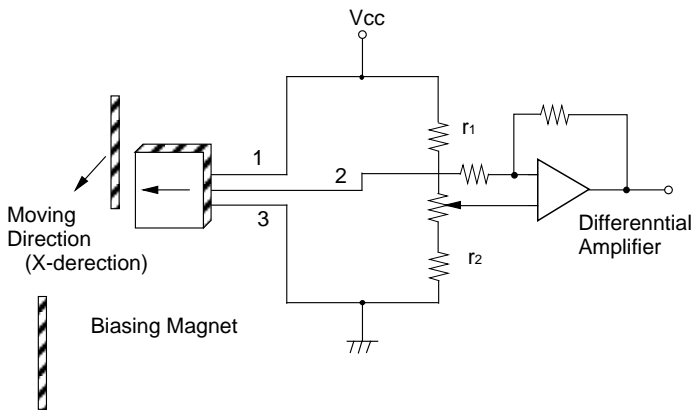

Bridge Circuits

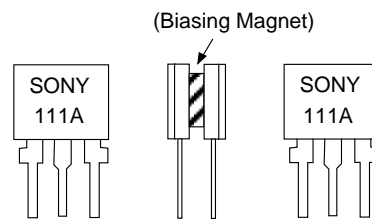
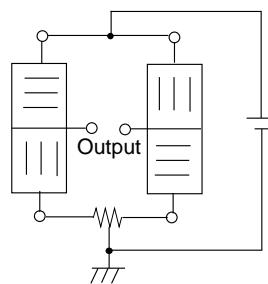

By coupling 2 pieces back to back and sticking item together in a bridge, the output voltage is doubled.

How to make a Biasing Magnetic Field

- Stick a rubber or ferrite biasing magnet
- Position an element between the poles of the permanent magnet.

Notes on Application

- Excute the solder of the lead line within 10 seconds at a temperature below 260°C
- To fix the ELEMENTS: When glue is used, DO NOT apply mechanical stress to the elements.
- Do not use this element in the dewy condition.

Example Representative Characteristics

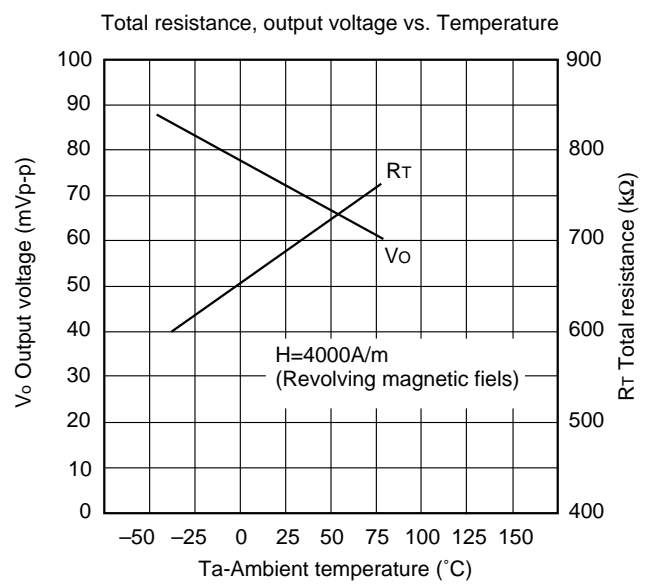
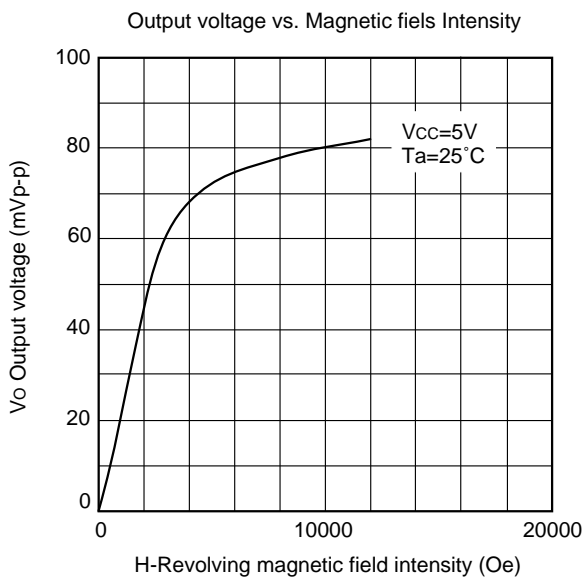
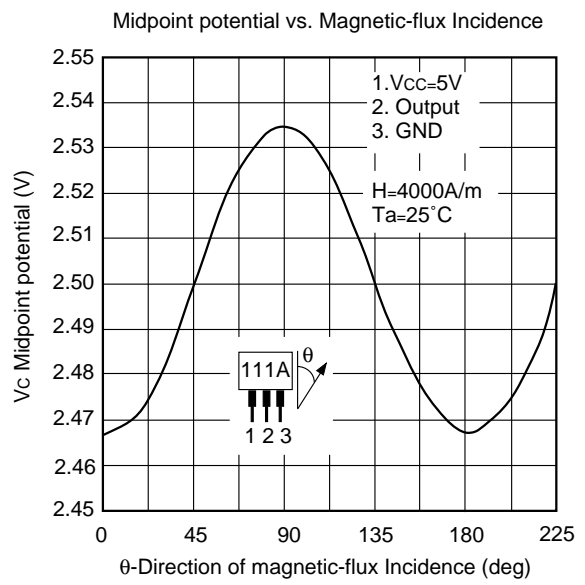
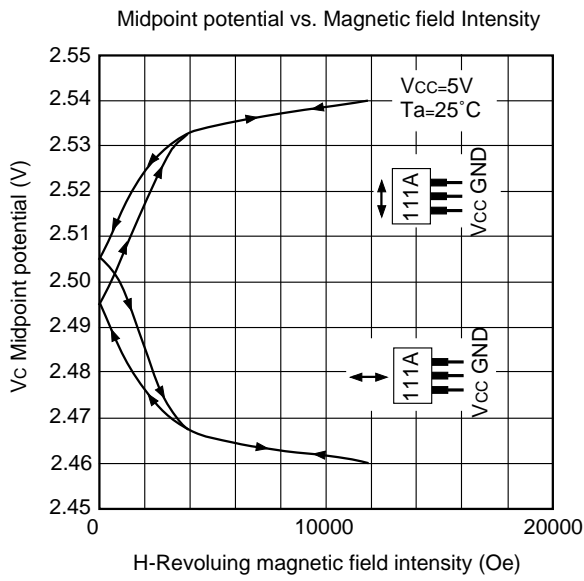

Package Outline Unit : mm

M-102

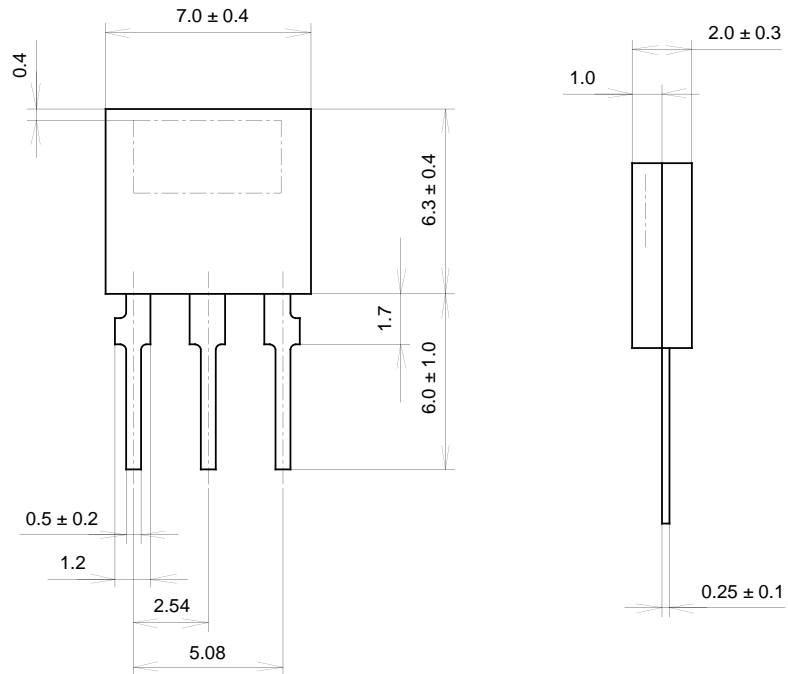

SONY CODE	M-102
EIAJ CODE	_____
JEDEC CODE	_____

PACKAGE WEIGHT	0.24g
----------------	-------