

Toroidal Inductors

Medium Current

CTP4561

CTP4561 is a medium current inductor with the following data and features:

- **Core type:** 1.06" o.d., Moly-Permalloy Powder, perm 125.
 - **Power rating:** 2.16 watts for temp. rise 50°C.
 - **Typical applications:** Switching Inductors in Switch Mode Power Supplies.
- Four mounting styles are offered:**
- 1 Flying leads (1.00"), for vertical or horizontal mounting.
 - 2 4-pin header, for vertical mounting.
 - 3 Threaded center hole, flying leads (2.00").
 - 4 2-pin header, for vertical mounting.



MECHANICAL

Style 1

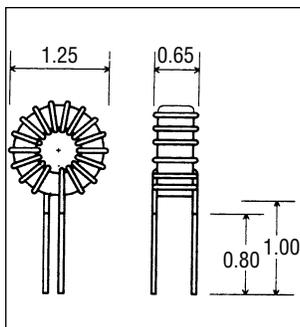

Style 2

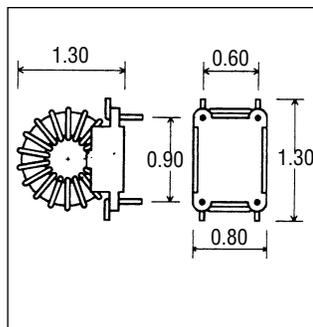

Style 3

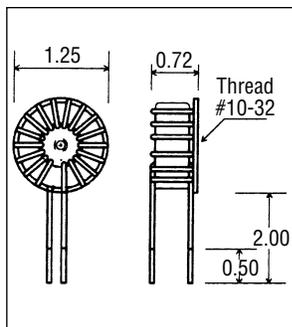

Style 4

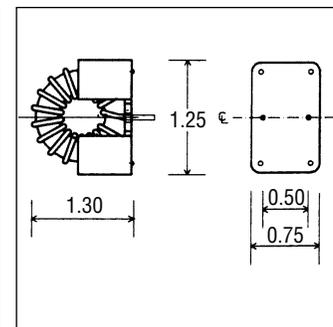

ELECTRICAL SPECIFICATION

Ordering Information: Substitute the style number for the asterisk (*). Example: CTP4561, Style 1, 56uH. Order: CTP4561 - 116

Part No. CTP4561 -	Ind. (uH)	DCR Ohms	Rated Current Amp. RMS	I (amp.) @ Lsat. 10%	I (amp.) @ Lsat. 25%	I (amp.) @ Lsat. 50%
* 01	3.3	0.002	34.8	22.0	33.1	55.1
* 02	3.9	0.002	33.5	20.3	30.4	50.7
* 03	4.7	0.003	28.5	18.5	27.7	46.2
* 04	5.6	0.003	27.4	16.9	25.4	42.3
* 05	6.8	0.004	23.3	15.4	23.0	38.4
* 06	8.2	0.004	22.3	14.0	21.0	35.0
* 07	10	0.005	21.3	12.7	19.0	31.7
* 08	12	0.007	18.1	11.6	17.3	28.9
* 09	15	0.007	17.2	10.3	15.5	25.8
* 10	18	0.010	14.6	9.4	14.2	23.6
* 11	22	0.011	13.9	8.5	12.8	21.3
* 12	27	0.015	11.8	7.7	11.6	19.3
* 13	33	0.017	11.3	7.0	10.5	17.4
* 14	39	0.019	10.8	6.4	9.6	16.0
* 15	47	0.020	10.3	5.8	8.8	14.6
* 16	56	0.022	9.9	5.4	8.0	13.4

Part No. CTP4561 -	Ind. (uH)	DCR Ohms	Rated Current Amp. RMS	I (amp.) @ Lsat. 10%	I (amp.) @ Lsat. 25%	I (amp.) @ Lsat. 50%
* 17	68	0.024	9.4	4.9	7.3	12.1
* 18	82	0.027	9.0	4.4	6.6	11.1
* 19	100	0.029	8.6	4.0	6.0	10.0
* 20	120	0.032	8.2	3.7	5.5	9.1
* 21	150	0.036	7.8	3.3	4.9	8.2
* 22	180	0.039	7.4	3.0	4.5	7.5
* 23	220	0.043	7.1	2.7	4.0	6.7
* 24	270	0.048	6.7	2.4	3.7	6.1
* 25	330	0.053	6.4	2.2	3.3	5.5
* 26	390	0.058	6.1	2.0	3.0	5.1
* 27	470	0.063	5.8	1.8	2.8	4.6
* 28	560	0.068	5.6	1.7	2.5	4.2

CTP4561