

Features

- Remote temperature measurement
- Fully linearised signals
- 125kb/s SPI
- Factory calibrated
- EEprom ECC
- Open drain relay driver output

Applications

- Automotive climate control
- Toasters, microwave ovens and other appliances that require temperature control
- Residential, commercial climate control and occupancy detection
- Industrial temperature transducer and monitoring applications

Ordering Information

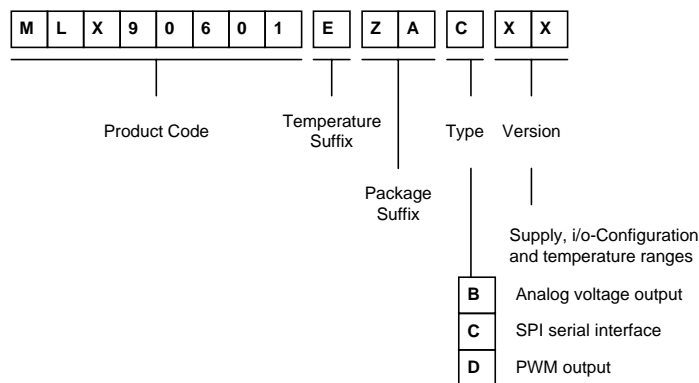

Part No	Temperature	Suffix			Description
		Package	Type	Version	
MLX90601	E	ZA	C	AA	digital SPI -20/120°C 5V supply
MLX90601	E	ZA	C	BA	digital SPI 5/60°C 5V supply

Functional Diagram

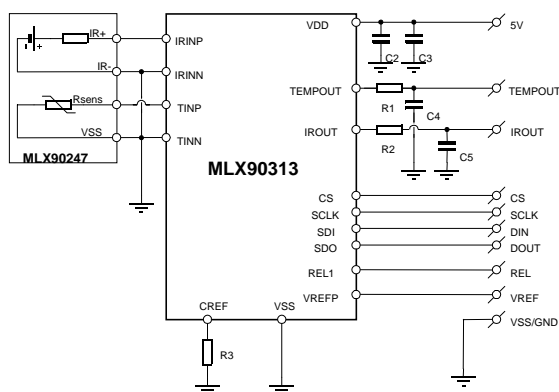

Description

The MLX90601C is a versatile IR thermometer module, which performs signal conditioning, linearisation and ambient temperature compensation. The module is built around the MLX90313 IR amplifier-interface, which uses high performance, chopper stabilized amplifiers, providing excellent noise performance. The sensing element is the MLX90247 discrete IR thermopile.

The module is delivered factory calibrated. The SPI offers both the sensor ambient temperature and the object temperature in 12 bit digital form. Additionally the module offers several analog pins for access to the programmable comparator circuitry and the reference voltage.

ELECTRICAL CHARACTERISTICS

Parameter	Symbol	Test Condition	Min	Typ	Max	Unit
Regulator and consumption						
Supply voltage range	Vin	VDD	4.5	5	6	V
Supply current	Idd	@ Ta=25°C		5	5.6	mA
POR threshold voltage	Vpor		1.1	1.3	1.5	V
IR-chain amplifier and output driver						
Power supply rejection ratio	PSSR	f ≤ 100kHz	75			dB
Input referred white noise	Vnir	rms-value			25	nV/√Hz
Chopper frequency	fc			8		kHz
Output voltage range		IROUT	0		Vdd-0.2	V
Output source current	Iod	IROUT	1			mA
Output sink current	Ios	IROUT	20			uA
DC Output impedance, drive	rod	IROUT			10	Ω
DC Output impedance, sink	ros	IROUT			100	Ω
Amplifier bandwidth	BW			500		Hz
Temp-chain amplifier and output driver						
Power supply rejection ratio	PSSR	f ≤ 100kHz	75			dB
Input referred white noise	Vntemp	rms-value			400	nV/√Hz
Chopper frequency	fc			15		kHz
Output voltage range	ORtemp	TEMPOUT	0		Vdd-0.2	V
Output source current	Iod	TEMPOUT	1			mA
Output sink current	Ios	TEMPOUT	20			uA
AC Output impedance	ro	TEMPOUT			100	Ω
Amplifier bandwidth	BW			500		Hz
Rel1 open drain relay driver						
High voltage protections			32			V
output impedance	Ro			10		Ω
ADC						
Monotonicity					guaranteed by design	
Differential non-linearity	DNL				0.4	LSB
Integral non-linearity	INL				½	LSB
Gain error		full scale			1	LSB
Total input-referred noise		Vref=3V			0.2	LSB
DAC						
Resolution				8		bit
Monotonicity					guaranteed by design	
Differential non-linearity	DNL				½	LSB
Integral non-linearity	INL				½	LSB
PWM						
PWM Clock period	Tclk		45	50	55	μs
PWM Total period	T		92.16	102.4	112.64	ms
Leading buffer time	t1	% of T		12.5		%
Trailing buffer time	t5	% of T		12.5		%
Duty cycle high	t2	% of T	0		50	%
Duty cycle low	t3	% of T	0		50	%
Error signal	t4	% of T		25		%
Rise time*		10% to 90% of Vh	13.3		100	μs

Parameter	Symbol	Test Condition	Min	Typ	Max	Unit
Fall time*		90% to 10% of V _H	13.3		100	μs
Output voltage high	V _H	I _{high} =2mA	4			V
Output voltage low	V _L	I _{low} =2mA			1	V

*Without external loading

General Description

MLX90601 is a versatile IR thermometer built around the MLX90247 Discrete IR thermopile sensor with on-chip PTC and the MLX90313 Programmable IR sensor interface. MLX90313 amplifies the signals coming from MLX90247 and converts them to digital by means of two high performance, low noise, chopper stabilized amplifiers and the 12-bit analog to digital converter. The digital unit on the interface then performs the ambient compensation of the IR signal. This results in two temperature signals, one representing the temperature of the object the IR sensor is pointed at (T_{object}) and one representing the temperature of the sensor (T_{ambient}). Both signals are then linearised and stored in dedicated registers, which are accessible through SPI (T_{object} at register address 09h, T_{ambient} at register address 0Ah).

The REL1 output is directly connected to the open drain relay driver output of the comparator circuitry inside MLX90313. The TEMPOUT pin is connected to a pseudo push-pull output stage of the second comparator. Both comparators can act on the linearised object or ambient temperature and have programmable hysteresis values and polarity settings.

Unique Features

MLX90601 is an automotive grade IR thermometer that can be fitted to any contactless temperature measurement application by means of the programmable Interfaces. The module is designed to cope with all standard qualification tests oriented towards the harsh automotive environment.

If so desired, all temperature ranges and comparator settings can be adapted to the application.

MLX90601 is delivered calibrated, relieving the customer of IR calibration.

Absolute Maximum Ratings

Supply Voltage, V _{DD} (overvoltage)	80V
Supply Voltage, V _{DD} (operating)	4.5V - 6V
Reverse Voltage Protection	-5V
Supply Current, I _{DD} @25°C	6 mA
Output Current, I _{OUT}	mA
Operating Temperature Range, T _A	-40°C - 125°C
Storage Temperature Range, T _S	-55°C - 150°C
ESD Susceptibility	4kV

Pinout

Pin	Symbol	Description
1	REL1	Open drain, relay driver comparator output
2	VSS	Ground
3	VDD	Supply pin
4	SDIN	SPI data input
5	SDOUT	SPI data output
6	CSB	SPI chip select input
7	SCLK	SPI clock input
8	IROUT	Object temperature output
9	VREF	Reference voltage
10	TEMPOUT	Ambient temperature output

Detailed Description

Analog Features

Supply

The module should be supplied directly with a nominal 5V regulated supply on pin VDD. (4.5V – 6V)

The power-on reset circuitry is completely internal to MLX90313. The module is fully operational 16 ms from the time the supply

crosses 1.3V. The POR circuit will issue another reset if the supply voltage goes below 1.3V.

A/D

The MLX90313 on the module contains a 12-bit internal analog to digital converter. Real 12-bit conversion is achieved by a fully differential analog part of the converter. Automatic calibration is implemented in the background, which allows precise conversion in a very wide temperature range.

Comparators

Two comparator circuits are available. Comparator 1 drives the Rel1 open drain output and is triggered by the linearised object temperature signal. The threshold level is programmed in the eeprom. Comparator 2 drives the TEMPOUT pin and is triggered by the linearised object temperature signal. The threshold level is programmed in EEPROM and can be changed through the SPI. Configuration and settings for the comparators are accessible through the SPI. For details please refer to the application note on the SPI.

Linearisation Unit

The linearisation unit of MLX90313 realizes 3 functions:

1. Offset measurement and calibration (offset drift compensation)
2. Measurement and offset cancellation
3. Linearisation.

Linearisation proceeds in two steps. In the first step the ambient temperature is calculated from the measured signal coming from the on-chip PTC temperature sensor of MLX90247. The value is stored in a dedicated register than is available for the output electronics.

In the second step the value of the ambient temperature is combined with the measured signal coming from the IR thermopile sensor inside MLX90247 to obtain a calculated value for the object temperature, based on the calibration data. The value is stored in a dedicated register and also available for the output electronics and SPI.

Sensor Characteristics

For detailed specification we refer to the datasheet on MLX90247, available from the Melexis website.

In a calibrated module the linearisation unit of MLX90313 takes all characteristics of the sensor into account, including all process variations they are subject to.

The TO-39 sensor housing of the thermopile has a 2.5mm diameter aperture, resulting in a 70° full angle field of view.

The silicon filter used as IR-window is treated with an antireflective coating that will pass minimum 75% of IR radiation in the wave length band from 7.5µm to 13.5µm. Below 5µm, 99.5% of incoming radiation is reflected by the filter

Serial Peripheral Interface (SPI)

Protocol

The digital interface implemented in MLX90313C is SPI compatible. It can be used to access the on-chip EEPROM and all internal registers. The chip will always work as a slave device. The format of any command is always 32 bits: 8 bits for the operation code, 8 bits for the address and 16 bits of data. The communication protocol is presented below.

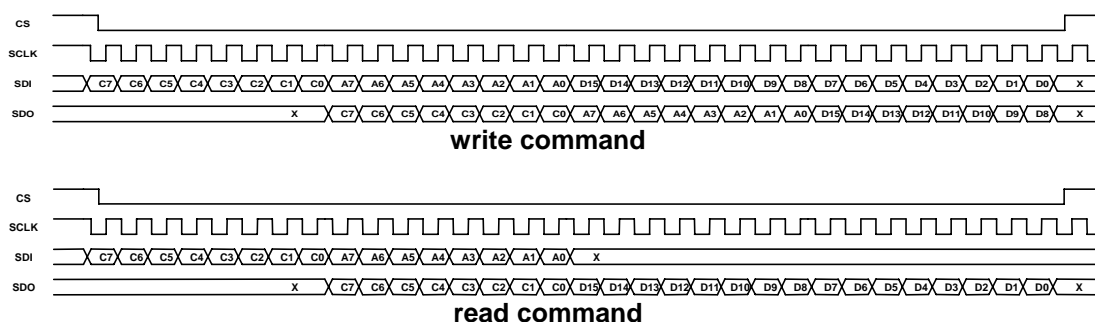

Every write command starts with a high to low transition of CS and ends by a low to high transition of CS after 32 periods of the serial data clock (SCLK). MLX90313C reads the data present on SDI on the rising edge of the clock. With a delay of 8 periods of the serial clock, the SPI will repeat the opcode, address and the first 8 bits of data on pin SDO. This allows the external master to check command and address and terminate the operation in case of an error by forcing CS high before the end of the complete command cycle, i.e. before the end of the 32 clock periods. The read command is build up similarly, except that no data has to be passed of course. On SDO the opcode will be followed directly by the

requested data, the address is not returned in this case.

The data on SDO is valid on the rising edge of the clock. In case of a read command, the SPI will output the data on SDO starting on the 25th rising edge of the clock (after CS low) as indicated in the figure above.

Timing/speed

The baud-rate depends on the serial data clock (SCLK) supplied by the master controller and is limited to 125kb/s. The timing requirements are given in the figure and table below

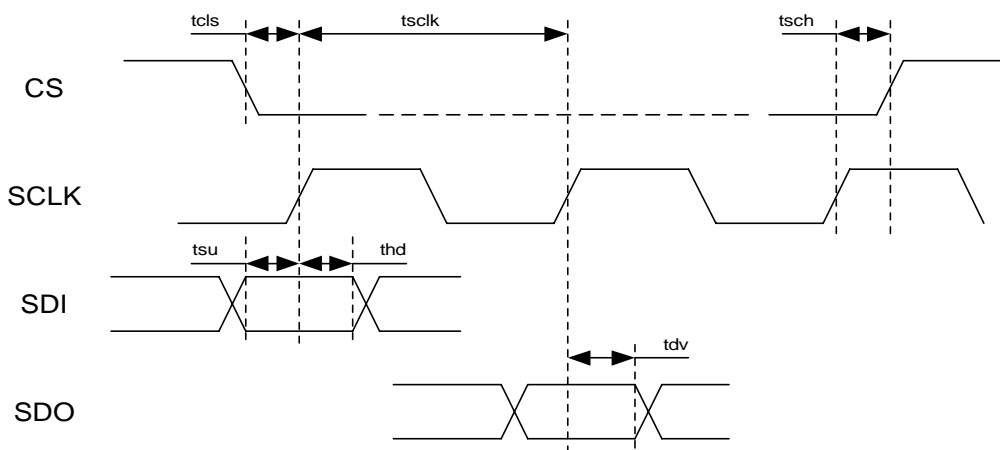

SPI timing requirements

Symbol	Parameter	Value	Unit
tsclk	Sclk period	min 8	μs
tcls	CS low to SCLK high	min 50	ns
tsch	SCLK low to CS high	min 50	ns
tsu	data in setup time	min 200	ns
thd	data in hold time	min 200	ns
tdv	data out valid	min 1	μs

operation codes

The operation code is the first series of 8bits in a command, C[7:0] in the figure on the protocol above.

Below table summarizes the operations available in MLX90313C.

Operation Codes		
mnem.	C[7:0]	Command
WR	x101x0xx	Write internal register
RD	x10010xx	Read internal register
WEPR	0001xxxx	Write EEprom
ER	001xxxxx	Erase EEprom
REPR	x0001xxx	Read EEprom
BLWR	1001xxxx	Block Write EEprom
BLER	101xxxxx	Block erase EEprom

Additional information on the SPI and use can be found in the application note on SPI.

Pin Descriptions

REL1

Open drain relay driver output. The typical on-resistance of this driver is $<10\Omega$ with a supply voltage of $VDD=5V$. The default configuration of comparator 1 is shown in the figure below.

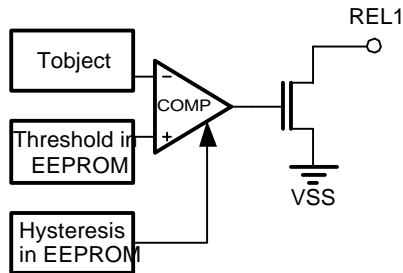

The comparator is a digital comparator, with a resolution of 12 bits. By default the input polarity is inverting. By default the trigger temperature is the object temperature but also the ambient (sensor) temperature can be used. Threshold and hysteresis values are version dependent, as indicated below.

Version	default REL1 settings	
	Threshold	Hysteresis
5/60°C version	45°C	$\pm 2^\circ\text{C}$
-20/120°C version	95°C	$\pm 5^\circ\text{C}$

It is possible to change the configuration and settings of the comparator through the SPI.

VSS: Supply pin

VDD: Supply pin

SDIN:

Serial data input pin for the SPI. Data is accepted on the rising edge of the serial data clock (SCLK)

DOUT:

Serial data output pin for the SPI. Data is valid on the rising edge of the serial data clock (SCLK)

CSB:

Active low, chip select pin for the SPI. Communication is started on the falling edge of CS and ended on the rising edge of CS.

SCLK:

Serial data clock from the external master to be supplied to this pin. Maximum frequency is 125kHz.

IROUT

In the default setting of the module, this pin is IR PWM coded temperature output. The driver can source or sink at least 2mA to/from an external load. It is possible to change the function of this pin by means of the SPI. By setting the appropriate values in the EEPROM configuration registers the pin can be used as analog output. For details on how to do this, please refer to the application note on the SPI. The details on the functionality of the IROUT pin in analog and PWM mode are covered in the datasheets on MLX90601B and MLX90601D respectively.

VREF

Voltage reference I/O pin. This level is by default dependent on the on-chip band-gap reference and can be programmed in the range 2-4.5V in EEPROM configuration registers. The default setting is 4.5V. This voltage is used as reference for ADC, DAC (analog outputs). The 90313 can be configured to use an external reference (2-5V) instead of the on-chip band-gap, if required.

TEMPOUT

In the default setting of the module, this pin is used as output for comparator2. The driver can source or sink at least 2mA to/from an external load. The default configuration of comparator 2 is shown in the figure below.

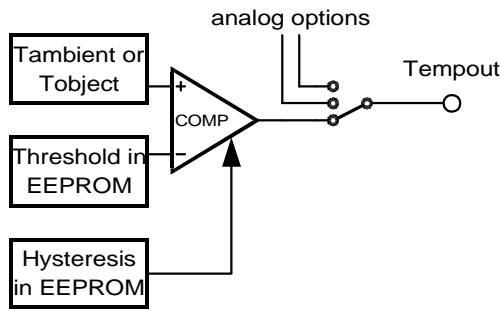

The comparator is a digital comparator, with a resolution of 12 bits. By default the input polarity is inverting. The default threshold and hysteresis values are version dependent, as indicated below.

default Comparator 2 settings

Version	Threshold	Hysteresis
5/60°C version	45°C	±2°C
-20/120°C version	95°C	±5°C

It is possible to change the configuration and settings of the comparator through the SPI.

It is possible to change the function of the TEMPOUT pin by means of the SPI. By setting the appropriate values in the EEPROM configuration registers the pin can be used as analog output or PWM output for the ambient temperature. For details on how to do this, please refer to the application note on the SPI. The details on the functionality of the TEMPOUT pin in analog and PWM mode is covered in the datasheets on MLX90601B and MLX90601D respectively.

Applications Information

Connection of the MLX90601 module into an application is straightforward. The 5V regulated supply should be connected between pin 3 (VDD) and pin 5 (VSS). There are numerous possibilities for the I/O of which one typical example is shown below. Here the default configuration is used. In the example a relay is switched with the REL1 output. The threshold for this comparator is programmed in the eeprom. This means the micro controller can change the threshold, and the MLX90601 can control the alarm standalone. The second comparator drives the TEMPOUT pin. The SPI connection to the host microcontroller can be a permanent connection in the application or just a means for in-circuit programming of the device. Through this connection full access to the internal registers and configuration settings is achieved. The SPI connection can also be used to directly read output data from the module in digital form and process this directly in the application. An interesting feature is in-circuit programming of the calibration constants. It is possible to change the range or emissivity, or whatever setting needs to be user selectable.

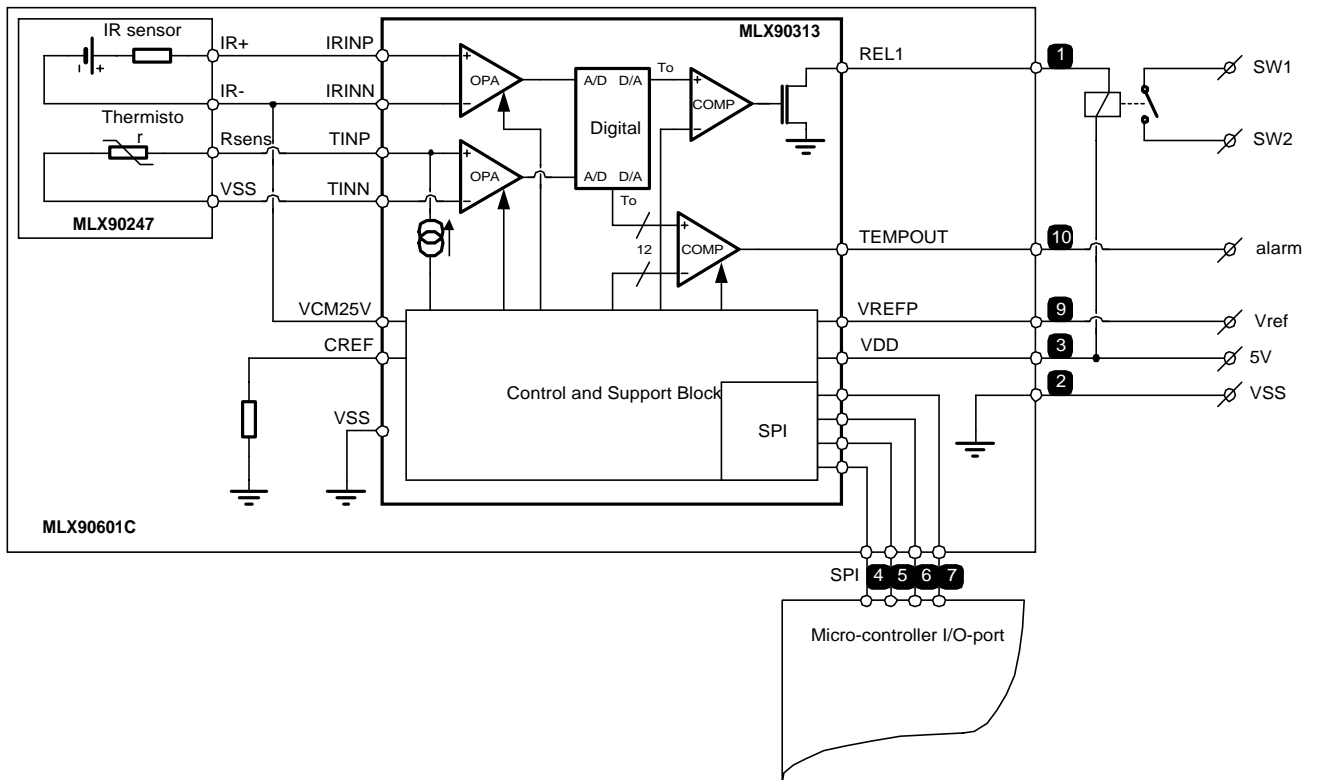

ESD Precautions

Electronic semiconductor products are sensitive to Electro Static Discharge (ESD). Always observe Electro Static Discharge control procedures whenever handling semiconductor products.

FAQ

Q: What is the accuracy?

A: For an object temperature range between 5°C and 60°C the accuracy of measurement is $\pm 1^\circ\text{C}$. For the wider object temperature range version (-20°C/120°C) the accuracy of measurement is $\pm 2^\circ\text{C}$.

Q: What is FOV?

A: The FOV or Field Of View is a definition of the area the sensor is 'seeing'. The sensor will detect radiation coming in at an angle, relative to the sensor's central axis, from 0° to 35°. The full viewing angle is thus 70°.

Q: What is the useful temperature range?

A: There are two temperature ranges of interest; the temperature of the object (or target), which you are trying to measure and the temperature of the sensor. The sensor temperature, called T_{ambient} , should be between 0°C and 50°C. Outside this range the ambient temperature compensation will no longer work and calculation of the object's temperature will no longer be correct. The TEMPOUT output will saturate under this condition. The object temperature, called T_{object} , should be between 5°C and 60°C. Outside this range the IROUT output will saturate.

Q: Can the temperature ranges be changed?

A: Yes, MLX90313 is a programmable device. Melexis selected a limited set of standard ranges that will fit the majority of applications in order to limit delivery times. However, if necessary, the ranges can be adapted for any particular application.

Glossary of Terms

ADC: Analog to Digital Converter

Ambient Compensation: The IR signal captured by a thermopile sensor is not only dependent

on the temperature of the object (T_{object}) but also on the temperature of the sensor itself. Therefore the IR signal is compensated for this effect by means of the measured sensor temperature (T_{ambient}). This rather complex calculation is performed in the linearisation unit of MLX90313.

Chopper Amplifier: Special amplifier configuration aimed at ultra low offset.

DAC: Digital to Analog Converter.

EEPROM: Non-volatile memory that can be electrically erased and rewritten. This type of memory is used to store configuration and calibration data for the module.

ECC: Error Checking and Correction. The EEPROM on board of MLX90313 is equipped with a checking and correction feature based on the Hamming Code method.

IR: Infrared. Every object emits infrared radiation in relation to its temperature. This effect can be used to measure this temperature without the need for physical contact.

Linearisation: The signal from a thermopile is not linear with the object temperature.

MLX90313 is therefore equipped with a digital calculation unit that produces an output that is linear with the object temperature.

POR: Power-on reset: Reset circuit that starts the digital system in a known state whenever the supply voltage is cycled

PSSR: Power Supply Rejection Ratio: Measure for an amplifier's immunity to disturbances on the supply connection.

PTC: See Thermistor

PWM: Pulse Width Modulation: Binary periodical signal which uses variation of the duty cycle to code information.

SPI: Serial Peripheral Interface. Commonly used, 4 wire, serial link to connect different circuits over a short distance

T_a , T_{ambient} : The temperature of the IR sensor.

Target: or Object: The object the IR module is aimed at.

Thermistor: Temperature dependant resistor. Basically there are 2 types. The types that increase their resistance with rising temperature are PTC (positive thermal coefficient) type. The ones that decrease their resistance with rising temperature we call NTC (negative thermal coefficient) type. The MLX90313 can work with both types. The MLX90601 modules are equipped with sensors that use PTCs.

T_o , T_{object} : The temperature of the object one wished to measure with the module

Disclaimer

Melexis reserves the right to periodically make modifications to product specifications. The information included herein is believed to be

accurate and reliable. However, Melexis assumes no responsibility for its use; nor for any infringements of patents or other rights of third parties, which may result from its use.
Melexis

Physical Characteristics

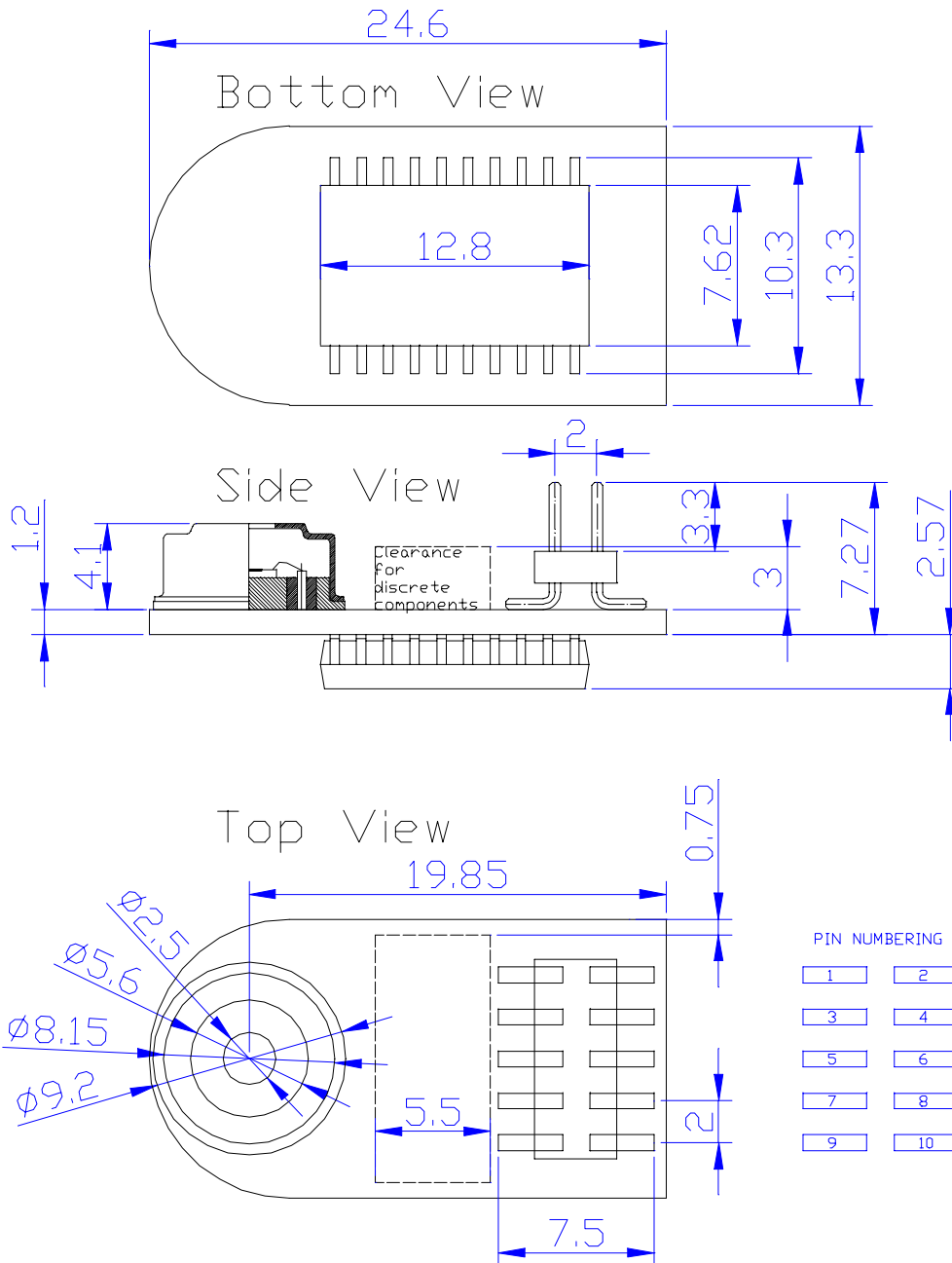

Future mechanical design on flex board

The mechanical outline of the MLX90601 module will change due to a transition from a rigid FR-4 substrate to a polyimide flexible film. Below drawing shows the future outline and pinning of the module

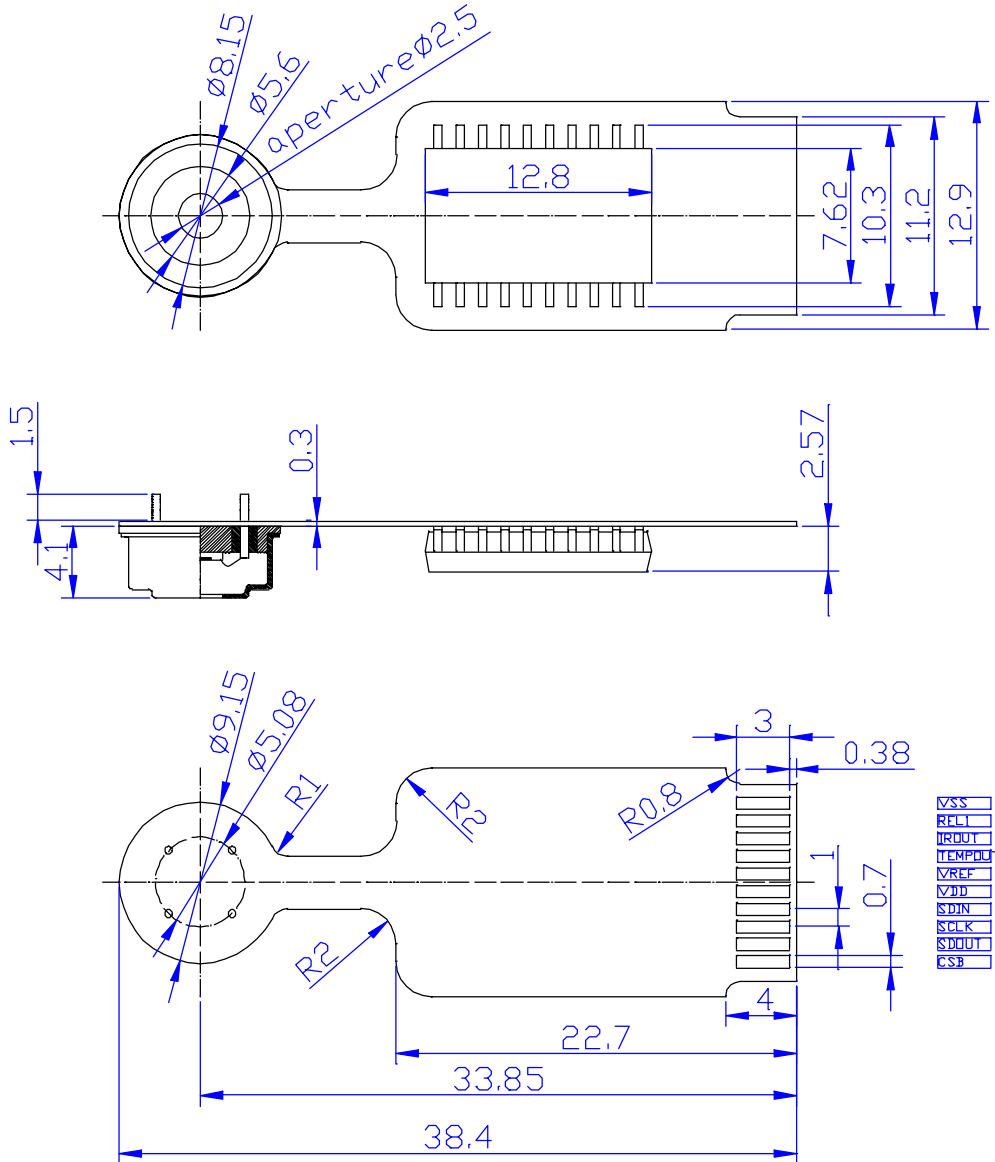

For the latest version of this document, go to our website at:
www.melexis.com

Or for additional information contact Melexis Direct:

Europe and Japan: Phone: +32 13 61 16 31
E-mail: sales_europe@melexis.com

All other locations: Phone: +1 603 223 2362
E-mail: sales_usa@melexis.com