



DOCUMENT NUMBER AND REVISION  
**VL-FS-MGLS128128-54C REV. A**  
(MGLS128128-HT-HV-G-LED03G-12)

DOCUMENT TITLE:  
**SPECIFICATION**  
**OF**  
**LCD MODULE TYPE**

DEPARTMENT	NAME	SIGNATURE	DATE
PREPARED BY	CHEN HUI JUAN	<i>Hj Chen</i>	2005.08.19
CHECKED BY	QIN SONG QING	<i>Qin Song Qing</i>	2005/08/22
APPROVED BY	WONG MAN CHARM	<i>Wong Man Charm</i>	2005/8/23

DISTRIBUTION LIST: MARKETING



### DOCUMENT REVISION HISTORY

DOCUMENT REVISION FROM TO	DATE	DESCRIPTION	CHANGED BY	CHECKED BY
A	2005.08.19	<p>First Release.</p> <p>Based on</p> <p>a.) Test Specification: VL-TS-MGLS128128-XX REV. U, 2005.05.05.</p> <p>b.) VL-QUA-012A REV. R, 2004.03.20.</p> <p>According to VL-QUA-012A, LCD size is small because Unit Per Laminate=8 which is more than 6pcs/Laminate.</p>	CHEN HUI JUAN	QIN SONG QING



## CONTENTS

	<u>Page No.</u>
1. GENERAL DESCRIPTION	4
2. MECHANICAL SPECIFICATIONS	4
3. ABSOLUTE MAXIMUM RATINGS	6
3.1 ELECTRICAL MAXIMUM RATINGS – FOR IC ONLY	6
3.2 ENVIRONMENTAL CONDITIONS	6
4. ELECTRICAL SPECIFICATIONS	7
4.1 INTERFACE SIGNALS	7
4.2 TYPICAL ELECTRICAL CHARACTERISTICS	8
4.3 TIMING SPECIFICATIONS	9
4.4 TIMING DIAGRAM OF VDD AGAINST VO	10
5. REMARK	11
6. LCD COSMETIC CONDITIONS	12



---

## VARITRONIX LIMITED

---

### Specification of LCD Module Type Model No.: MGLS128128-54C

#### 1. General Description

- 128 x 128 dots STN Positive Transflective Yellow LCD Graphic Module
- Driving scheme: 1/128 duty, 1/12.4 bias.
- Viewing direction: 12 o'clock.
- 'Toshiba' T6963C-0101 flat pack or equivalent LCD Controller.
- 'Toshiba' T6A40 flat pack or equivalent LCD Common Drivers.
- 'Toshiba' T6A39 flat pack or equivalent LCD Segment Drivers.
- 8 K byte display RAM.
- Yellow-green LED03 backlight.
- FPC inter-connection.

#### 2. Mechanical Specifications

The mechanical detail is shown in Fig. 1 and summarized in Table 1 below.

Table 1

Parameter	Specifications	Unit
Outline dimensions	92.0 (W) x 106.0(H) x 14.5MAX.(D)	mm
Viewing area	73.0(W) x 73.0(H)	mm
Active area	70.35(W) x 70.35(H)	mm
Display format	128 (Horizontal) x 128 (Vertical)	dots
Dot size	0.50(W) x 0.50(H)	mm
Dot spacing	0.05(W) x 0.05(H)	mm
Dot pitch	0.55(W) x 0.55(H)	mm
Weight	Approx. 119.0	gram





### 3. Absolute Maximum Ratings

#### 3.1 Electrical Maximum Ratings – for IC Only

Table 2

Parameter	Symbol	Min.	Max.	Unit
Supply voltage (Logic)	VDD - VSS	-0.3	+7.0	V
Supply voltage (LCD drive)	VLCD=VDD – V0	-0.3	+28.0	V
Input voltage	Vin	-0.3	VDD +0.3	V

Note:

- 1.) The module may be destroyed if they are used beyond the absolute maximum ratings.
- 2.) All voltage values are referenced to VSS = 0V.

#### 3.2 Environmental Conditions

Table 3

Item	Operating Temperature (Topr)		Storage Temperature (Tstg) (Note 1)		Remark
	Min.	Max.	Min.	Max.	
Ambient Temperature	-20°C	+70°C	-30°C	+80°C	Dry
Humidity	90% max. RH for Ta ≤ 40°C			No condensation	
Vibration (IEC 68-2-6) cells must be mounted on a suitable connector	Frequency: 10 ~ 55 Hz Amplitude: 0.75 mm Duration: 20 cycles in each direction.			3 directions	
Shock (IEC 68-2-27) Half-sine pulse shape	Pulse duration: 11 ms Peak acceleration: 981 m/s <sup>2</sup> = 100 g Number of shocks: 3 shocks in 3 mutually perpendicular axes.			3 directions	

Note 1: Product cannot sustain in extreme storage conditions for a long time.



## 4. Electrical Specifications

### 4.1. Interface signals

Table 4

Pin No.	Symbol	Description
1	FGND	Frame Ground (see note 1)
2	VSS	Ground (0V)
3	VDD	Power supply for logic (+5V)
4	V0	Power supply for LCD drive
5	$\overline{WR}$	Command/Data write to module when "L"
6	$\overline{RD}$	Command/Data read from module when "L"
7	$\overline{CE}$	Chip enable of controller when "L"
8	$C/\overline{D}$	Command/Data read /write. "H" for command read/write and "L" for data read/write.
9	$\overline{RST}$	Controller reset when "L"
10	DB0	Data input/output (LSB)
11	DB1	Data input/output
12	DB2	Data input/output
13	DB3	Data input/output
14	DB4	Data input/output
15	DB5	Data input/output
16	DB6	Data input/output
17	DB7	Data input/output (MSB)
18	FS	Font select. "H" for 6 x 8 font & "L" for 8 x 8 font
19	LED+(A)	Anode of LED backlight.
20	LED-(K)	Cathode of LED backlight.

Note 1: This pin is electrically connected to the metal bezel (frame).  
User can choose to connect this pin to VSS or leave it open.



## 4.2 Typical Electrical Characteristics

At Ta = 25 °C, VDD = 5V±5%, VSS = 0V.

Table 5

Parameter	Symbol	Conditions	Min.	Typ.	Max.	Unit
Supply voltage (Logic)	VDD –VSS		4.75	5.00	5.25	V
Supply voltage (LCD)	VLCD =VDD –V0	VDD = 5V,Note 1	19.8	20.3	20.8	V
Input signal voltage	VIN	“H” level	VDD -2.2	-	VDD	V
		“L” level	0	-	0.8	V
Supply current (Logic & LCD)	IDD	Character mode, VDD = 5V,Note 1	-	9.1	13.8	mA
		Checker board mode, VDD = 5V,Note 1	-	9.6	14.4	mA
Supply current (LCD)	I0	Character mode, VDD = 5V,Note 1	-	3.8	5.7	mA
		Checker board mode, VDD = 5V,Note 1	-	4.1	6.1	mA
Supply voltage of yellow-green LED03 backlight	VLED	Forward current =180mA  Number of LED chips=2x12=24	3.9	4.1	4.3	V
Wavelength of yellow-green LED03 backlight	λ		-	568	-	nm
Backlight luminance (on the backlight surface)			17.6	22	-	cd/m <sup>2</sup>

Note 1: There is tolerance in optimum LCD driving voltage during production and it will be within the specified range.





### 4.3 Timing Specifications

At  $T_a = -20^{\circ}\text{C}$  To  $+70^{\circ}\text{C}$ ,  $V_{DD} = 5V \pm 5\%$ ,  $V_{SS} = 0V$

Refer to Fig. 2, the bus timing diagram.

Table 6

Parameter	Symbol	Min.	Max.	Unit
C/D Set-up time	$t_{CDS}$	100	-	ns
C/D Hold Time	$t_{CDH}$	10	-	ns
/CE,/RD,/WR Pulse Width	$t_{CE}, t_{RD}, t_{WR}$	80	-	ns
Data Set-up Time	$t_{DS}$	80	-	ns
Data Hold Time	$t_{DH}$	40	-	ns
Access Time	$t_{ACC}$	-	150	ns
Output Hold Time	$t_{OH}$	10	50	ns

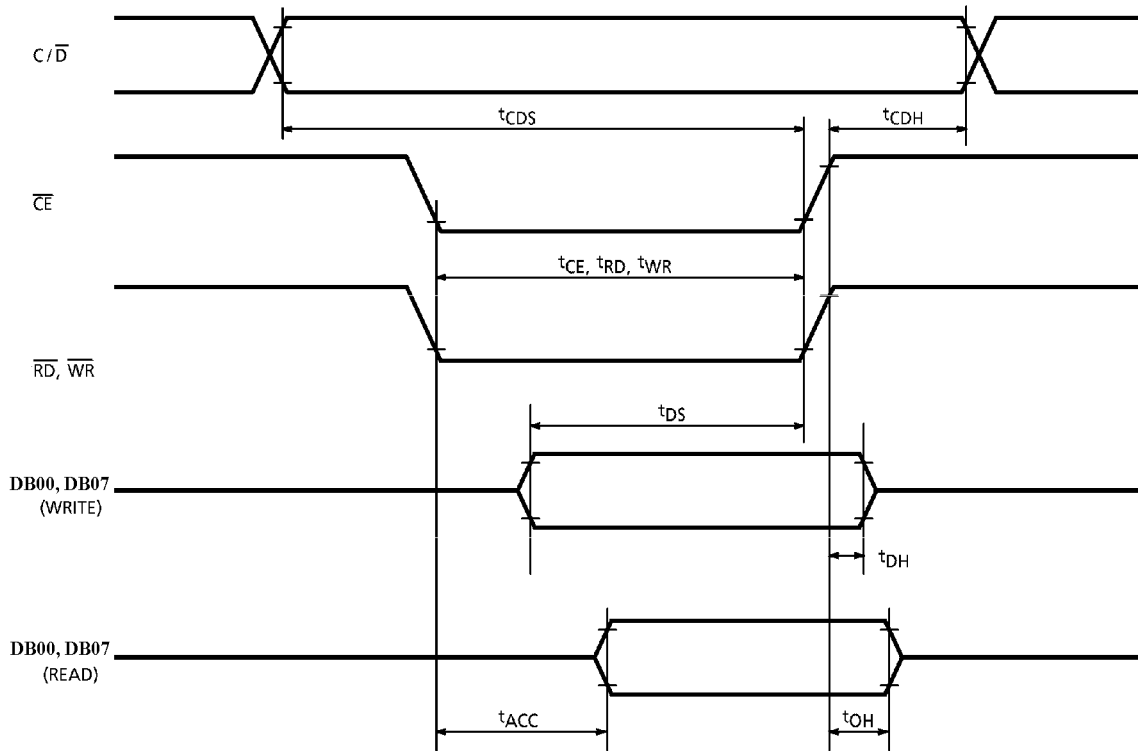

Figure 2: Bus Timing Diagram



#### 4.4 Timing Diagram of VDD Against V0.

Power on sequence shall meet the requirement of Figure 3, the timing diagram of VDD against V0.

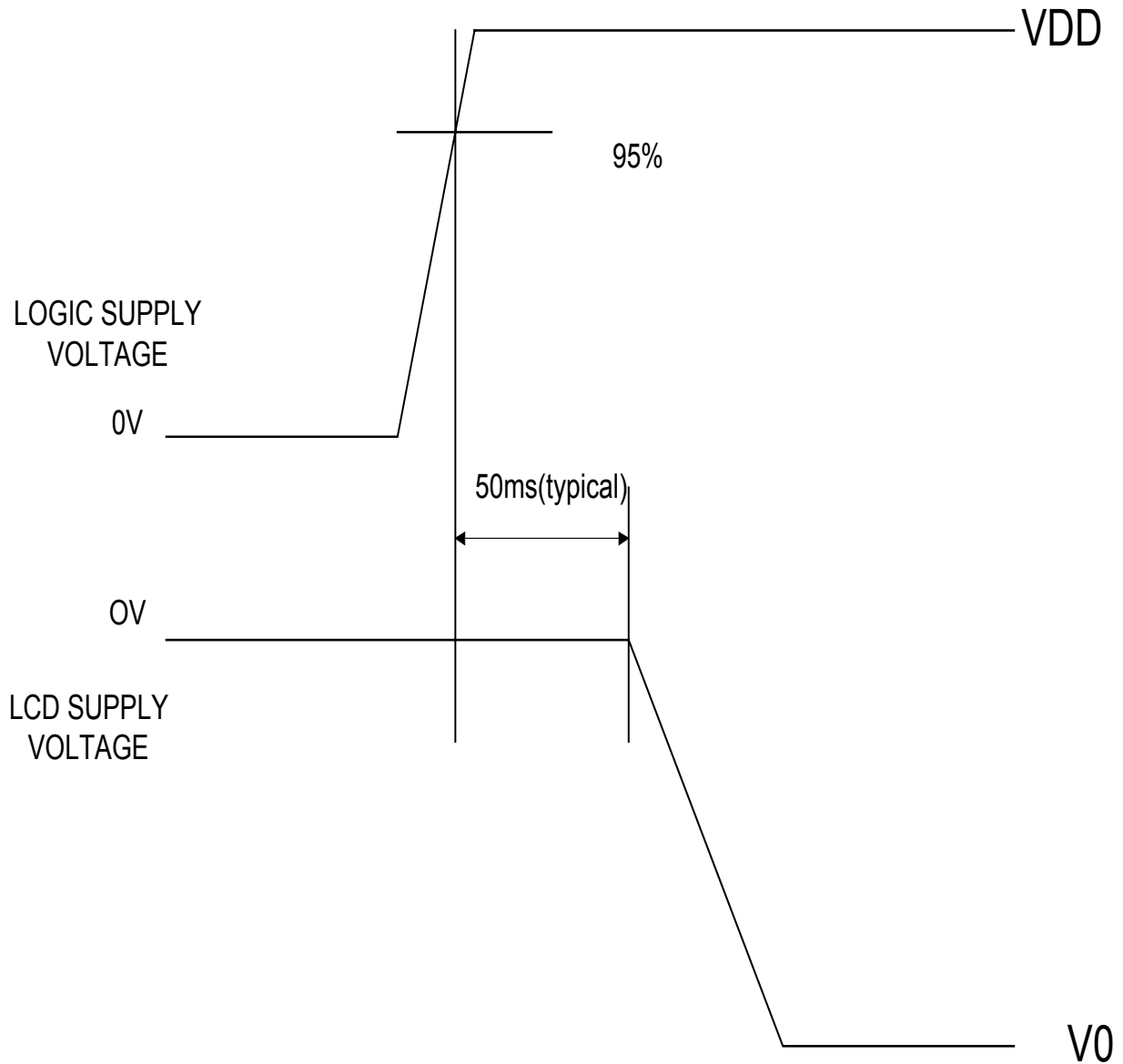

Figure 3: Timing Diagram of VDD Against V0.



## 5. Remark

### HANDLING LCD AND LCD MODULES

#### 1. Liquid Crystal Display (LCD)

LCD is made up of glass, organic sealant, organic fluid and polymer based polarizers. The following precautions should be taken when handling:

- (1) Keep the temperature within range for use and storage. Excessive temperature and humidity could cause polarization degradation, polarizer peel-off or bubble generation. When storage for a long period over 40° C is required, the relative humidity should be kept below 60%.
- (2) Do not contact the exposed polarizers with anything harder than an HB pencil lead. To clean dust off the display surface, wipe gently with cotton, chamois or other soft material soaked in petroleum benzin. Never scrub hard.
- (3) Varitronix does not responsible for any polarizer defect after the protective film has been removed from the display
- (4) Wipe off saliva or water drops immediately. Contact with water over a long period of time may cause polarizer deformation or color fading, while an active LCD with water condensation on its surface will cause corrosion of ITO electrodes.
- (5) PETROLEUM BENZIN is recommended to remove adhesives used to attach front/rear polarizers and reflectors, while chemicals like acetone, toluene, ethanol and isopropyl alcohol will cause damage to the polarizer. Avoid oil and fats. Avoid lacquer and epoxies which might contain solvents and hardeners to cause electrode erosion. Some solvents will also soften the epoxy covering the DIL pins and thereby weakening the adhesion of the epoxy on glass. This will cause the exposed electrodes to erode electrochemically when operating in high humidity and condensing environment.
- (6) Glass can be easily chipped or cracked from rough handling, especially at corners and edges.
- (7) Do not drive LCD with DC voltage.
- (8) When soldering DIL pins, avoid excessive heat and keep soldering temperature between 260°C to 300°C for no more than 5 seconds. Never use wave or reflow soldering.

#### 2. Liquid Crystal Display Modules (MDL)

##### 2.1 Mechanical Considerations

MDL's are assembled and adjusted with a high degree of precision. Avoid excessive shocks and do not make any alterations or modifications. The following should be noted.

- (1) Do not tamper in any way with the tabs on the metal frame.
- (2) Do not modify the PCB by drilling extra holes, changing its outline, moving its components or modifying its pattern.
- (3) Do not touch the elastomer connector (conductive rubber), especially when inserting an EL panel.

- (4) When mounting a MDL make sure that the PCB is not under any stress such as bending or twisting. Elastomer contacts are very delicate and missing pixels could result from slight dislocation of any of the elements.
- (5) Avoid pressing on the metal bezel, otherwise the elastomer connector could be deformed and lose contact, resulting in missing pixels.
- (6) If FPCA need to be bent, please refer the suggested bending area on the specification. The stiffener and component area on FPC/FFC/COF must not be bent during or after assembly (Note: for those models with FPC/FFC/COF +stiffener).
- (7) Sharp bending should be avoided on FPC to prevent track cracking.

##### 2.2 Static Electricity

MDL contains CMOS LSI's and the same precaution for such devices should apply, namely:

- (1) The operator should be grounded whenever he comes into contact with the module. Never touch any of the conductive parts such as the LSI pads, the copper leads on the PCB and the interface terminals with any part of the human body.
- (2) The modules should be kept in antistatic bags or other containers resistant to static for storage.
- (3) Only properly grounded soldering irons should be used.
- (4) If an electric screwdriver is used it should be well grounded and shielded from commutator sparks.
- (5) The normal static prevention measures should be observed for work clothes and working benches; for the latter conductive (rubber) mat is recommended.
- (6) Since dry air is inducive to statics, a relative humidity of 50 - 60% is recommended.

##### 2.3 Soldering

- (1) Solder only to the I/O terminals.
- (2) Use only soldering irons with proper grounding and no leakage.
- (3) Soldering temperature is 280°C ± 10°C .
- (4) Soldering time: 3 to 4 seconds.
- (5) Use eutectic solder with resin flux fill.
- (6) If flux is used, the LCD surface should be covered to avoid flux spatters. Flux residue should be removed afterwards.
- (7) Use proper de-soldering methods (e.g. suction type desoldering irons) to remove lead wires from the I/O terminals when necessary. Do not repeat the soldering/ desoldering process more than three times as the pads and plated through holes may be damaged.

##### 2.4 Label

Identification labels will be stuck on the module without

obstructing the viewing area of display.

#### 3. Operation

- (1) The viewing angle can be adjusted by varying the LCD driving voltage Vo.
- (2) Driving voltage should be kept within specified range, excess voltage shortens display life.
- (3) Response time increases with decrease in temperature.
- (4) Display may turn black or dark Blue at temperatures above its operational range; this is however not destructive and the display will return to normal once the temperature falls back to range.
- (5) Mechanical disturbance during operation (such as pressing on the viewing area) may cause the segments to appear "fractured". They will recover once the display is turned off.
- (6) Condensation at terminals will cause malfunction and possible electrochemical reaction. Relative humidity of the environment should therefore be kept below 60%.
- (7) Display performance may vary out of viewing area. If there is any special requirement on performance out of viewing area, please consult Varitronix.

#### 4. Storage and Reliability

- (1) LCD's should be kept in sealed polyethylene bags while MDL's should use antistatic ones. If properly sealed, there is no need for desiccant.
- (2) Store in dark places and do not expose to sunlight or fluorescent light. Keep the temperature between 0°C and 35°C and the relative humidity low. Please consult VARITRONIX for other storage requirements.
- (3) Water condensation will affect reliability performance of the display and is not allowed.
- (4) Semi-conductor device on the display is sensitive to light and should be protected properly.
- (5) Power up/down sequence.
  - a) Power Up: in general, LCD supply voltage, Vo must be supplied after logic voltage, VDD becomes steady. Please refer to related IC data sheet for details.
  - b) Power Down: in general, LCD supply voltage, Vo must be removed before logic voltage, VDD turns off. Please refer to related IC data sheet for details.

#### 5. Safety

If any fluid leaks out of a damaged glass cell, wash off any human part that comes into contact with soap and water. Never swallow the fluid. The toxicity is extremely low but caution should be exercised at all times.

### LIMITED WARRANTY

VARITRONIX LCDs and modules are not consumer products, but may be incorporated by VARITRONIX's customers into consumer products or components thereof. VARITRONIX does not warrant that its LCDs and components are fit for any such particular purpose.

1. The liability of VARITRONIX is limited to repair or replacement on the terms set forth below. VARITRONIX will not be responsible for any subsequent or consequential events or injury or damage to any personnel or user including third party personnel and/or user.

Unless otherwise agreed in writing between VARITRONIX and the customer, VARITRONIX will only replace or repair any of its LCD which is found defective electrically or visually when inspected in

accordance with VARITRONIX LCD Acceptance Standards (copies available on request), for a period of one year from the date of shipment. Confirmation of such date shall be based on freight documents.

2. No warranty can be granted if any of the precautions stated in HANDLING LCD and LCD Modules above have been disregarded. Broken glass, scratches on polarizers, mechanical damages as well as defects that are caused by accelerated environmental tests are excluded from warranty.
3. In returning the LCD and Modules, they must be properly packaged and there should be detailed description of the failures or defects.

### IMPORTANT NOTICE

The information presented in this document has been carefully checked and is believed to be accurate, however, no responsibility is assumed for inaccuracies. VARITRONIX reserves the right to make changes to any specifications without further notice for performance, reliability, production technique and other considerations. VARITRONIX does not assume any liability arising out of the application or use of products herein. Please see Limited Warranty in the previous section.



**6. LCD Cosmetic Conditions**

- a.) Reference document follow VL-QUA-012A.
- b.) LCD size of the product is small.

“Varitronix Limited reserves the right to change this specification.”

FAX: (852) 2343-9555.

URL: <http://www.varitronix.com>

- END -