

# AlGaAs SP5T Reflective PIN Diode Switch

# MA4AGSW5

## Features

- Ultra Broad Bandwidth: 50 MHz to 50 GHz
- 1.7 dB Insertion Loss, 30 dB Isolation at 50 GHz
- Low Current consumption.
  - 10 mA for low loss state
  - +10 mA for Isolation state
- M/A-COM's unique patent pending AlGaAs hetero-junction anode technology.
- Silicon Nitride Passivation
- Polyamide Scratch protection

## Description

M/A-COM's MA4AGSW5 is an Aluminum-Gallium-Arsenide anode enhanced, SP5T PIN diode switch. AlGaAs anodes, which utilize M/A-COM's patent pending hetero-junction technology, produce less loss than conventional GaAs processes, by as much as 0.3 dB reduction in insertion loss at 50 GHz. These devices are fabricated on a OMCVD epitaxial wafer using a process designed for high device uniformity and extremely low parasitics. The diodes themselves exhibit low series resistance, low capacitance, and fast switching speed. They are fully passivated with silicon nitride and have an additional layer of a polymer for scratch protection. The protective coating prevents damage to the junction and the anode air bridges during handling. Off-chip bias circuitry is required and allows maximum design flexibility.

## Applications

The low capacitance of the PIN diodes makes this device ideal for use in microwave multi-throw switch designs. The low series resistance of the diodes reduces the insertion loss of the devices at microwave/millimeter-wave frequencies. These AlGaAs PIN switches are used as switching arrays on radar systems, optical switching networks, instrumentation, and other wideband multi-throw switch assemblies.

## MA4AGSW5 Layout

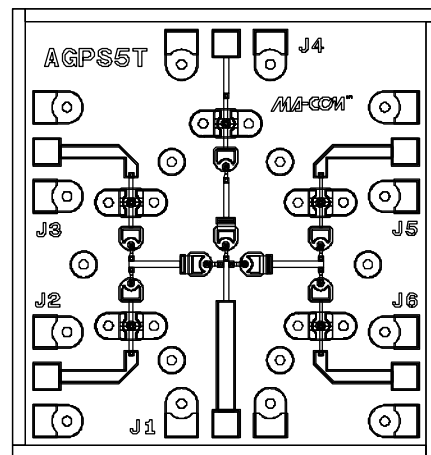

## Absolute Maximum Ratings<sup>1</sup> @ T= Room Temp. (Unless otherwise specified)

Parameter	Maximum Rating
Operating Temperature	-55 °C to +125 °C
Storage Temperature	-65 °C to +150 °C
RF C.W. Incident Power	+ 23 dBm C. W.
Breakdown Voltage	25 V
Bias Current	+/- 30 mA per Diode

1. Exceeding any of these values may result in permanent damage

**Electrical Specifications @ 25 °C (On-Wafer Measurements)**

RF Parameter	Frequency Band	Port	Bias	Min	Max	Units
Insertion Loss	0.05 - 18 GHz 18 - 50 GHz	J2 to J1	-10 mA @ J2, +10 mA @ J3, J4, J5, J6	-	1.4	dB
		J2 to J1		-	1.9	dB
	0.05 - 18 GHz 18 - 50 GHz	J3 to J1	-10 mA @ J3, +10 mA @ J2, J4, J5, J6	-	1.4	dB
		J3 to J1		-	1.9	dB
	0.05 - 18 GHz 18 - 50 GHz	J4 to J1	-10 mA @ J4, +10 mA @ J2, J3, J5, J6	-	1.4	dB
		J4 to J1		-	1.9	dB
	0.05 - 18 GHz 18 - 50 GHz	J5 to J1	-10 mA @ J5, +10 mA @ J2, J3, J4, J6	-	1.4	dB
		J5 to J1		-	1.9	dB
	0.05 - 18 GHz 18 - 50 GHz	J6 to J1	-10 mA @ J6, +10 mA @ J2, J3, J4, J5	-	1.4	dB
		J6 to J1		-	1.9	dB
Isolation	0.05 - 18 GHz 18 - 50 GHz	J2 to J1	-10 mA @ J6, +10 mA @ J3, J4, J5, J2	35.0	-	dB
		J2 to J1		30.0	-	dB
	0.05 - 18 GHz 18 - 50 GHz	J3 to J1	-10 mA @ J6, +10 mA @ J2, J4, J5, J2	35.0	-	dB
		J3 to J1		30.0	-	dB
	0.05 - 18 GHz 18 - 50 GHz	J4 to J1	-10 mA @ J6, +10 mA @ J2, J3, J5, J2	35.0	-	dB
		J4 to J1		30.0	-	dB
	0.05 - 18 GHz 18 - 50 GHz	J5 to J1	-10 mA @ J6, +10 mA @ J2, J3, J4, J2	35.0	-	dB
		J5 to J1		30.0	-	dB
	0.05 - 18 GHz 18 - 50 GHz	J6 to J1	-10 mA @ J2, +10 mA @ J2, J3, J4, J6	35.0	-	dB
		J6 to J1		30.0	-	dB
In/Out Return Loss	0.05 - 18 GHz 18 - 50 GHz	J2 to J1	-10 mA @ J2, +10 mA @ J3, J4, J5, J6	12.0	-	dB
		J2 to J1		12.0	-	dB
	0.05 - 18 GHz 18 - 50 GHz	J3 to J1	-10 mA @ J3, +10 mA @ J2, J4, J5, J6	12.0	-	dB
		J3 to J1		12.0	-	dB
	0.05 - 18 GHz 18 - 50 GHz	J4 to J1	-10 mA @ J4, +10 mA @ J2, J3, J5, J6	12.0	-	dB
		J4 to J1		12.0	-	dB
	0.05 - 18 GHz 18 - 50 GHz	J5 to J1	-10 mA @ J5, +10 mA @ J2, J3, J4, J6	12.0	-	dB
		J5 to J1		12.0	-	dB
	0.05 - 18 GHz 18 - 50 GHz	J6 to J1	-10 mA @ J6, +10 mA @ J2, J3, J4, J5	12.0	-	dB
		J6 to J1		12.0	-	dB

Parameter	F (GHz)	RF Ports	Test Conditions	Typ Value	Units
Switching Speed (10-90%) RF Voltage)	10.0	J1 to J2, J3, J4, J5, J6	+/-5 V TTL Compatible PIN Diode Driver	15	nS

**NOTES:**

1. Isolation is measured through (3) Diodes from Common Port ( Input ) to Selected Output Port with (1) Opposite Series Junction Diode in Low Loss. Isolation for (2) Diodes from Common Port ( Input ) to Selected Output with the Same Series Junction Diode Port in Low Loss = 22 dB Typical.
2. Typical switching speed is measured from 10% to 90% of the detected RF voltage driven by a +/- 5V TTL compatible driver. Driver output parallel RC network uses a capacitor between 390 pF - 560 pF and a resistor between 150 - 220 Ohms to achieve 15 ns rise and fall times.

Microwave Performance

Typical Insertion Loss @ 25 °C (On Wafer Measurements)

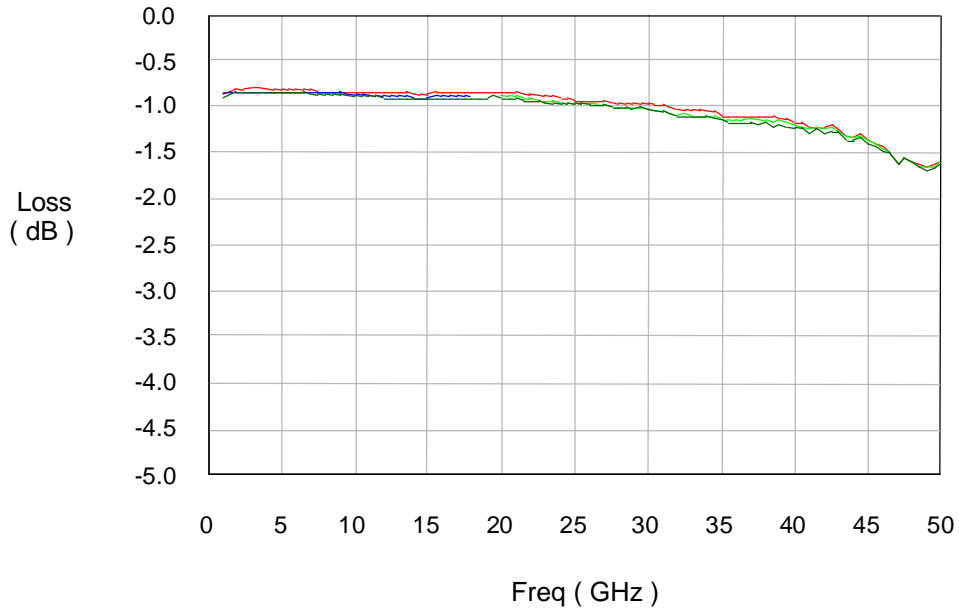

Typical Input Return Loss @ 25 °C (On Wafer Measurements)

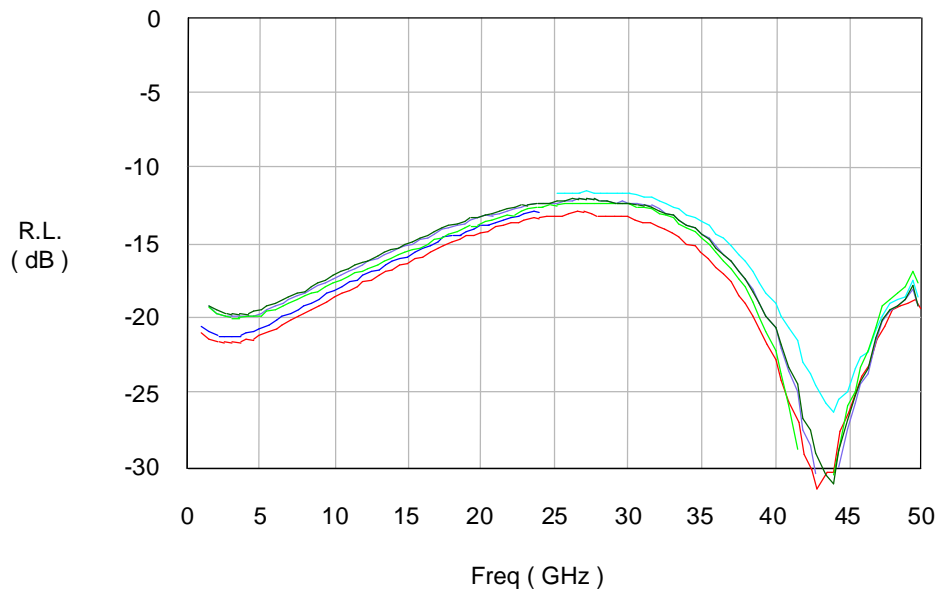

M/A-COM Inc. and its affiliates reserve the right to make changes to the product(s) or information contained herein without notice.

Visit [www.macom.com](http://www.macom.com) for additional data sheets and product information.

- North America: Tel. (800) 366-2266
- Asia/Pacific: Tel.+81-44-844-8296, Fax +81-44-844-8298
- Europe: Tel. +44 (1908) 574 200, Fax+44 (1908) 574 300

Microwave Performance

Typical Output Return Loss @ 25 °C (On Wafer Measurements)

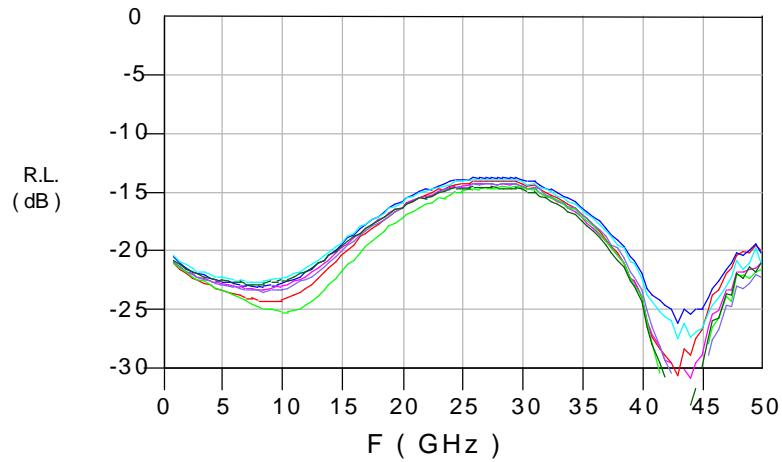

Typical Isolation @ 25 °C (On Wafer Measurements)

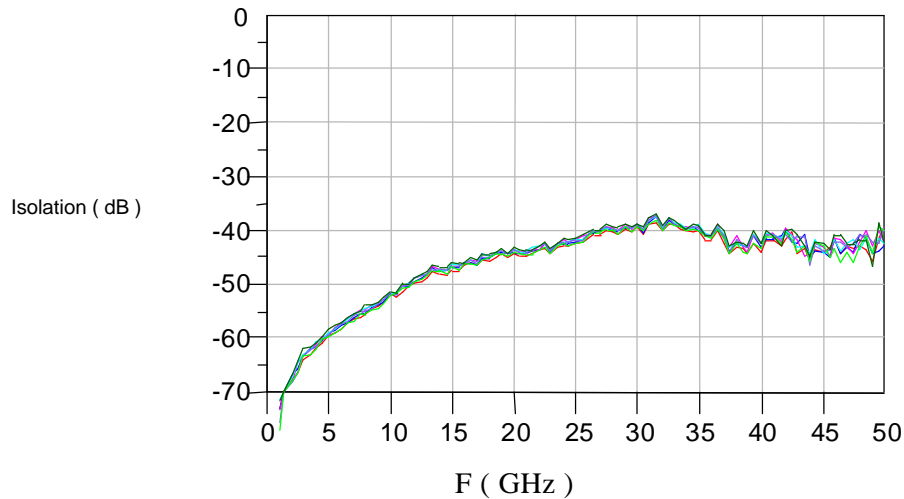

Chip Dimensions (mm and mils)

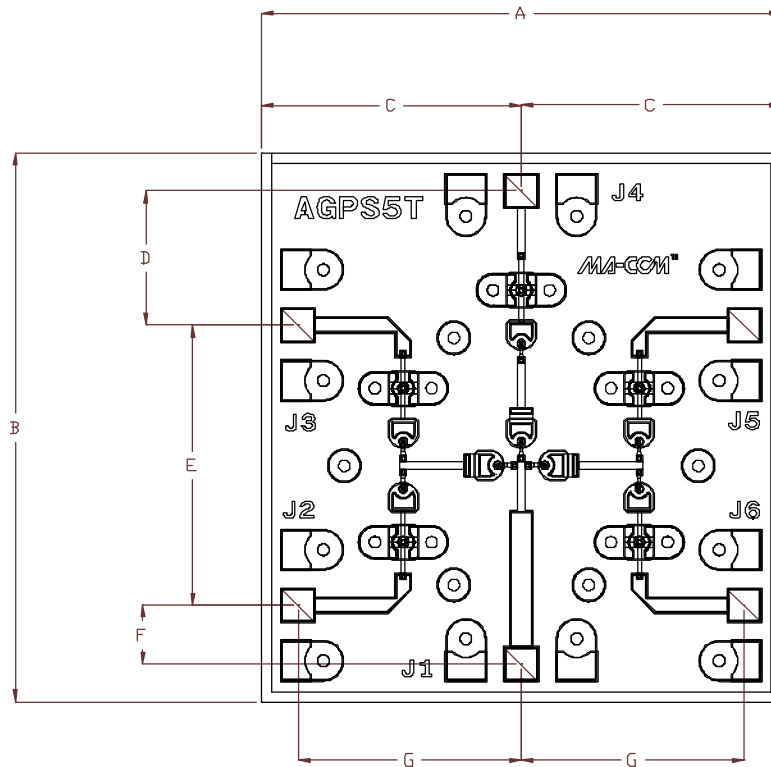

Dim	mm		mils	
	Min.	Max.	Min.	Max.
A	1.53	1.56	60.0	61.2
B	1.61	1.64	63.2	64.4
C	0.76	0.79	29.7	30.9
D	0.39	0.41	15.2	16.0
E	0.82	0.84	32.2	33.0
F	0.16	0.18	6.5	7.2
G	0.65	0.67	25.7	26.5
Thickness	0.09	0.11	3.7	4.3

## Handling Procedures

The following precautions should be observed to avoid damaging these chips.

## Cleanliness

These chips should be handled in a clean environment. Do not attempt to clean die after installation.

## Static Sensitivity

Proper ESD techniques should be used when handling these devices.

## General Handling

The protective polymer coating on the active areas of these die provides scratch and impact protection, particularly for the metal air bridge which contacts the diode's anode. Die should primarily be handled with vacuum pickups, or alternatively with plastic tweezers.

## Mounting Techniques

These AlGaAs devices are designed to be mounted with electrically conductive silver epoxy or with a lower temperature solder perform.

## Operation of the MA4AGSW5 Switch

The Simultaneous Application of Negative D.C. Current to the Low Loss Port and Positive DC current to the Remaining Isolated Switching Ports provides operation of the MA4AGSW Series of AlGaAs PIN Switches. The Backside Area of the Die is the RF and DC Return Ground Plane. The DC Return is achieved on Common Port J1. Constant Current Sources should supply the DC Control Currents. The individual Diode Voltages in the circuit are typically  $< | 1.5 \text{ V} |$  up to  $\pm 30 \text{ mA}$ . In the Low Loss State, the Series Diodes must be Forward Biased and the Shunt Diode Reverse Biased. For All the Isolated Ports, the Shunt Diode is Forward Biased and the Series Diode is Reverse Biased. RF to D.C. bias networks are required, such as the MA4BN1840-1. The Bias Network Design should yield  $> 30 \text{ dB}$  RF to DC Isolation in the operating frequency band.

Best Insertion Loss, P1dB, IP3, and Switching Speed is Achieved by using a Voltage Pull-up Resistor in the DC Return Path, ( J1 ). A Minimum Value of  $| -3.5\text{V} |$  is recommended at this Return Node, which is achievable with a Standard ,  $\pm 5 \text{ V}$  TTL Controlled PIN Diode Driver.

## Solder Die Attachment

All die attach and bonding methods should be compatible with gold metal. Solder which does not scavenge gold, such as 80Au/20Sn or Indalloy #2 is recommended. Do not expose die to a temperature greater than  $300 \text{ }^\circ\text{C}$  for more than 10 seconds.

## Electrical Conductive Epoxy Die Attachment

Assembly can be preheated to approximately  $125 \text{ }^\circ\text{C}$ . Use a controlled thickness of approximately 2 mils for best electrical and thermal conductivity. Cure epoxy as per manufacturer's schedule. For extended cure times, temperatures should be kept below  $150 \text{ }^\circ\text{C}$ .

## Ribbon/Wire Bonding

Wedge thermo compression bonding or ball bonding may be used to attach ribbons to the bonding pads. Gold ribbons should be  $1/4 \times 3 \text{ mil sq.}$  for all RF ports (J1-J6) for lowest inductance and best microwave performance.

MA4AGSW5 Schematic

