

LED Dome and On-Axis Multi-Light (200 mm)



Features

- Combining the dome light and on-axis light provides outstanding illumination uniformity
- Ideal for extremely difficult specular surfaces
- Light intensity for each axis is independently adjustable
- Black anodized aluminum housing

LED Dome and On-Axis Multi-Light Model

Models	Illumination Type	Color	Cable	Supply Voltage	Supply Current	Connections
LEDRC200N [†]	Continuous highly-diffused dome and on-axis light	Red 640 nm	Detachable 1.8 m (6') cable terminated with 9-pin D-sub connectors (male pins)	12V dc $\pm 10\%$ with voltage regulation of $\pm 1\%$	2.2 A max.	Pin 1 = +V fan Pin 2 = dc common fan Pin 3 = dc common Pin 4 = +V dome Pin 5 = +V on-axis Power supply model PS2V-12(E) is recommended (see other side)

[†] This model is not stocked and is non-returnable.

Suggested Field-of-view	75 mm (3")
Suggested Stand-off	25 mm (1")
Useful Life	60,000 hours
Environmental Rating	IEC IP20; NEMA 1
Operating Conditions	Temperature: 0° to 40°C (+32° to 104°F) Maximum relative humidity: 95% at 40°C (non-condensing)

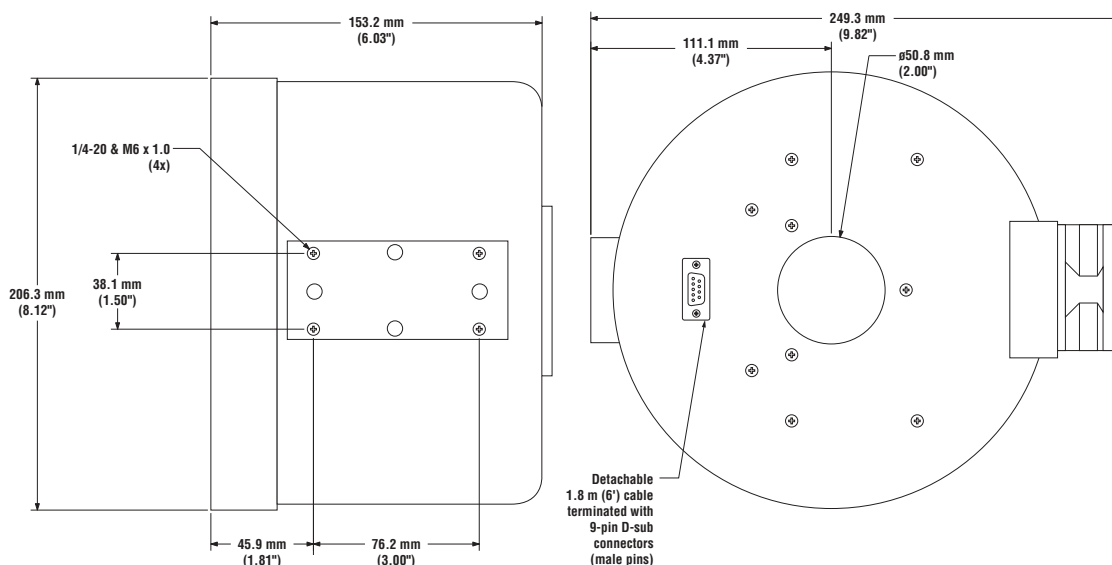

WARRANTY: Banner Engineering Corp. warrants its products to be free from defects for one year. Banner Engineering Corp. will repair or replace, free of charge, any product of its manufacture found to be defective at the time it is returned to the factory during the warranty period. This warranty does not cover damage or liability for the improper application of Banner products. This warranty is in lieu of any other warranty either expressed or implied.

LED Dome and On-Axis Multi-Light (200 mm)

Accessories

Variable Power Supplies (see data sheet p/n 67449)

Models	Input	Input Cord	Output	Output Cable	Used with	
PS2V-12†	100-140V ac 60 Hz	North America (NEMA 5-15)	2-channels 6 - 12V dc 2 A max. per channel	1.8 m (6') Terminated with 9-pin D-sub connector (female pins)	Continuous types: LEDRC200N	
PS2V-12E†	200-250V ac 50 Hz	Cont. Europe (Schuko CEE 7)				

Extension Cables

Models	Length	Configuration	Used with
DB906†	1.8 m (6')	Terminated both ends with 9-pin D-sub connector, for continuous lights (one end male pins and opposite end female pins)	Continuous types: LEDRC200N
DB910†	3.0 m (10')		

† These models are not stocked and are non-returnable.