

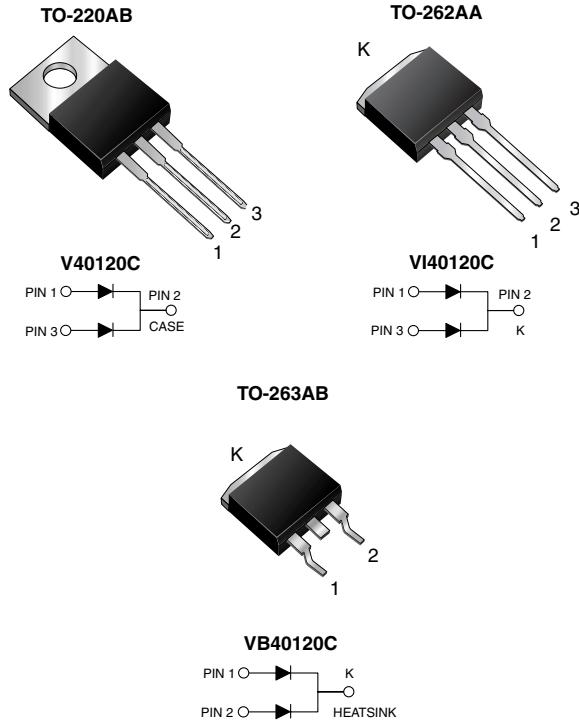

Dual High-Voltage Trench MOS Barrier Schottky Rectifier

Ultra Low $V_F = 0.423$ V at $I_F = 5$ A



FEATURES

- Trench MOS Schottky Technology
- Low forward voltage drop, low power losses
- High efficiency operation
- Low thermal resistance
- Meets MSL level 1, per J-STD-020C, LF max peak of 245 °C (for TO-263AB package)
- Solder Dip 260 °C, 40 seconds (for TO-220 & TO-262 package)
- Component in accordance to RoHS 2002/95/EC and WEEE 2002/96/EC



TYPICAL APPLICATIONS

For use in high frequency inverters, switching power supplies, free-wheeling diodes, oring diode, dc-to-dc converters and reverse battery protection.

MECHANICAL DATA

Case: TO-220AB, TO-262AA & TO263AB

Epoxy meets UL 94V-0 flammability rating

Terminals: Matte tin plated leads, solderable per J-STD-002B and JESD22-B102D

E3 suffix for commercial grade

Polarity: As marked

Mounting Torque: 10 in-lbs maximum

MAJOR RATINGS AND CHARACTERISTICS	
$I_{F(AV)}$	2 x 20 A
V_{RRM}	120 V
I_{FSM}	250 A
V_F at $I_F = 20$ A	0.630 V
T_j max.	150 °C

MAXIMUM RATINGS ($T_A = 25$ °C unless otherwise noted)					
PARAMETER	SYMBOL	V40120C	VB40120C	VI40120C	UNIT
Maximum repetitive peak reverse voltage	V_{RRM}	120			V
Maximum average forward rectified current (see Fig. 1)	$I_{F(AV)}$		40	20	A
Peak forward surge current 8.3 ms single half sine-wave superimposed on rated load	I_{FSM}		250		A
Peak repetitive reverse current per diode at $t_p = 2$ μ s, 1 kHz	I_{RRM}		1.0		A
Voltage rate of change (rated V_R)	dv/dt		10000		V/ μ s
Operating junction and storage temperature range	T_J, T_{STG}	- 20 to + 150			°C

ELECTRICAL CHARACTERISTICS (T _A = 25 °C unless otherwise noted)					
PARAMETER	TEST CONDITIONS	SYMBOL	TYP.	MAX.	UNIT
Breakdown voltage	at I _R = 1.0 mA T _j = 25 °C	V _(BR)	120 (minimum)	-	V
Instantaneous forward voltage per diode (1)	at I _F = 5 A I _F = 10 A T _j = 25 °C I _F = 20 A	V _F	0.494 0.584 0.768	- - 0.84	V
	at I _F = 5 A I _F = 10 A T _j = 125 °C I _F = 20 A		0.423 0.518 0.630	- - 0.68	
Reverse current at rated V _R per diode (1)	at V _R = 90 V T _j = 25 °C T _j = 125 °C	I _R	11 10	- -	μA mA
	at V _R = 120 V T _j = 25 °C T _j = 125 °C		31 22	500 40	μA mA

Note:

(1) Pulse test: 300 μs pulse width, 1 % duty cycle

THERMAL CHARACTERISTICS (T _A = 25 °C unless otherwise noted)					
PARAMETER	SYMBOL	V40120C	VB40120C	VI40120C	UNIT
Typical thermal resistance per diode	R _{θJC}	2.0			°C/W

ORDERING INFORMATION					
PACKAGE	PREFERRED P/N	UNIT WEIGHT (g)	PACKAGE CODE	BASE QUANTITY	DELIVERY MODE
TO-220AB	V40120C-E3/45	2.248	45	50/Tube	Tube
TO-263AB	VB40120C-E3/4W	1.39	4W	50/Tube	Tube
TO-263AB	VB40120C-E3/8W	1.39	8W	800/Reel	Tape & Reel
TO-262AA	VI40120C-E3/4W	1.458	4W	50/Tube	Tube

RATINGS AND CHARACTERISTICS CURVES

(T_A = 25 °C unless otherwise noted)

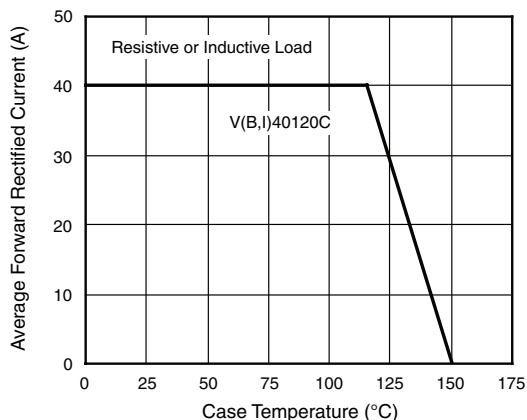

Figure 1. Maximum Forward Current Derating Curve

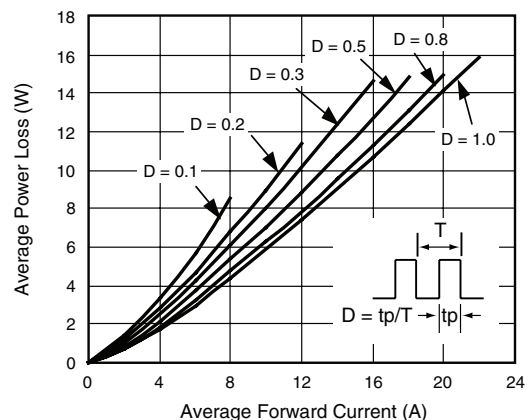

Figure 2. Forward Power Loss Characteristics Per Diode

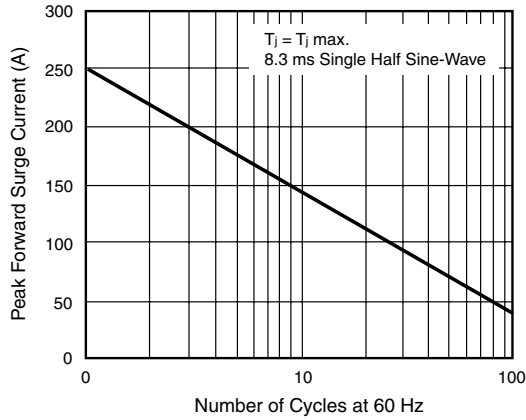

Figure 3. Maximum Non-Repetitive Peak Forward Surge Current Per Diode

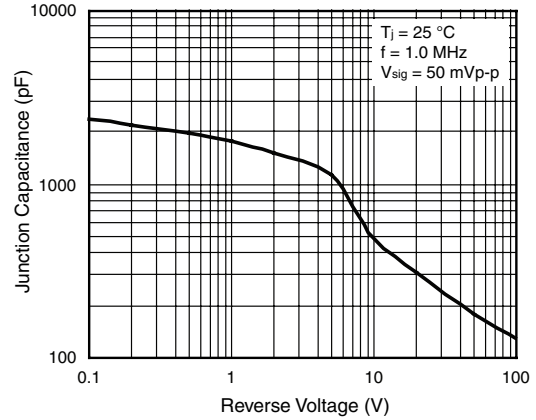

Figure 6. Typical Junction Capacitance Per Diode

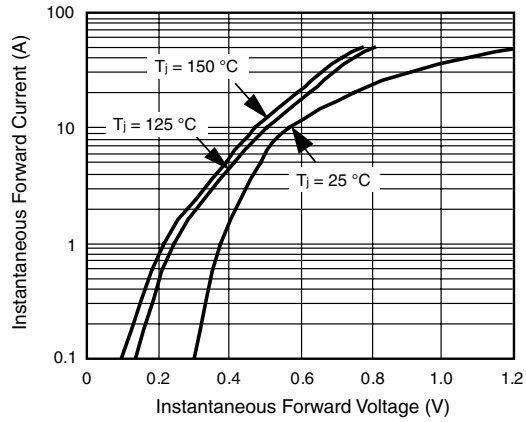

Figure 4. Typical Instantaneous Forward Characteristics Per Diode

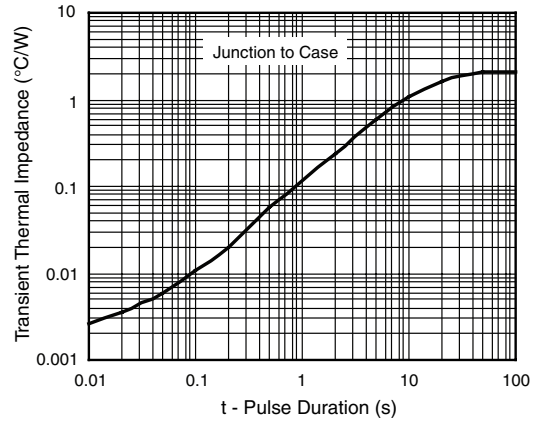

Figure 7. Typical Transient Thermal Impedance Per Diode

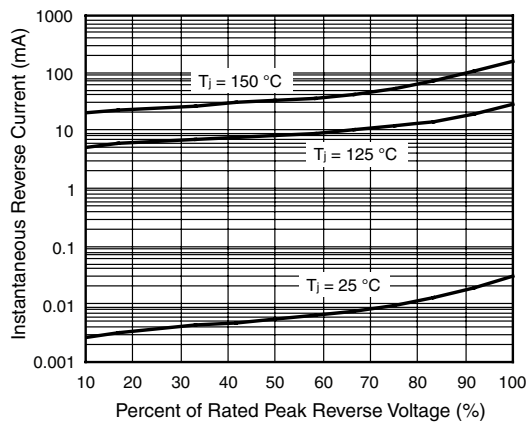

Figure 5. Typical Reverse Characteristics Per Diode

V40120C, VB40120C & VI40120C

Vishay General Semiconductor



PACKAGE OUTLINE DIMENSIONS in inches (millimeters)

TO-220AB

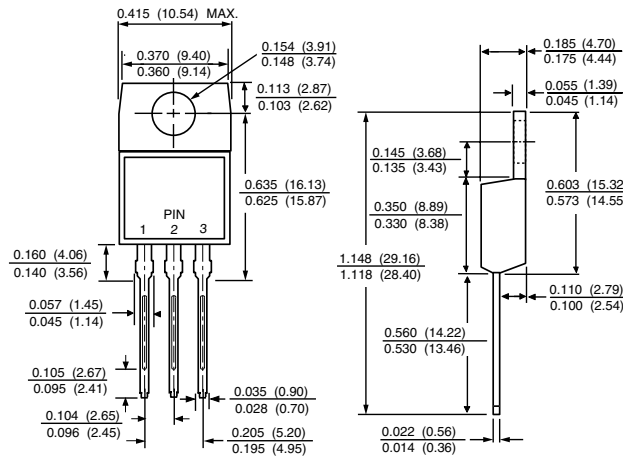

TO-262AA

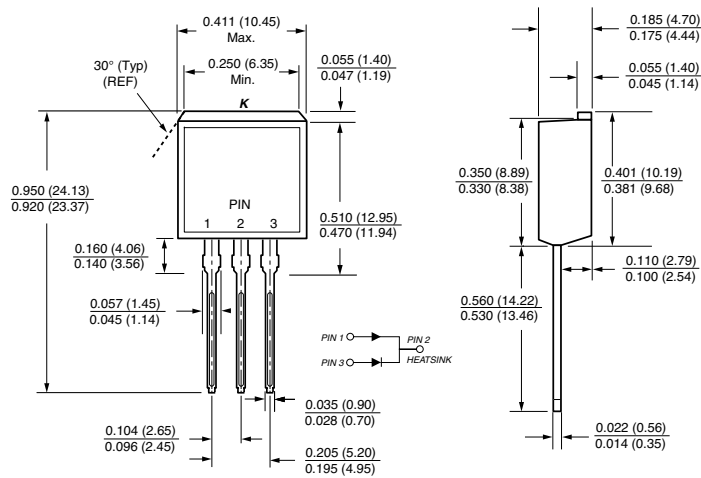

TO-263AB

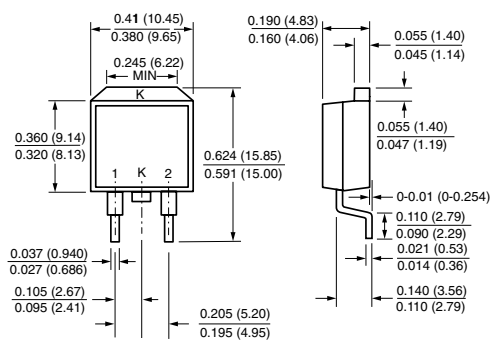

Mounting Pad Layout

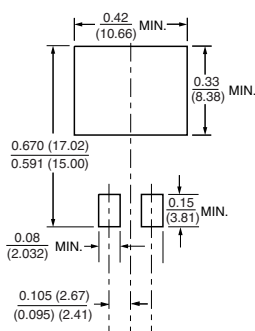



Notice

Specifications of the products displayed herein are subject to change without notice. Vishay Intertechnology, Inc., or anyone on its behalf, assumes no responsibility or liability for any errors or inaccuracies.

Information contained herein is intended to provide a product description only. No license, express or implied, by estoppel or otherwise, to any intellectual property rights is granted by this document. Except as provided in Vishay's terms and conditions of sale for such products, Vishay assumes no liability whatsoever, and disclaims any express or implied warranty, relating to sale and/or use of Vishay products including liability or warranties relating to fitness for a particular purpose, merchantability, or infringement of any patent, copyright, or other intellectual property right.

The products shown herein are not designed for use in medical, life-saving, or life-sustaining applications. Customers using or selling these products for use in such applications do so at their own risk and agree to fully indemnify Vishay for any damages resulting from such improper use or sale.