

TOSHIBA BIPOLAR LINEAR INTEGRATED CIRCUIT SILICON MONOLITHIC

# TA1243BF

## RF MODULATOR FOR VCR

The TA1243BF is a PLL RF modulator for the UHF frequency range. The multi system can easily make the line up development.

### FEATURES

- Phase locked loop frequency synthesizer for RF carrier and sound subcarrier
- Programmable of no adjustment sound subcarriers (4.5MHz, 5.5MHz, 6.0MHz, 6.5MHz)
- Possible to use for L-SECAM
- Programmable picture to sound ratio
- Bus controlled Test pattern Signal Generator
- Bus controlled one logic output port
- Bus controlled power save mode
- Controlled by I<sup>2</sup>C bus

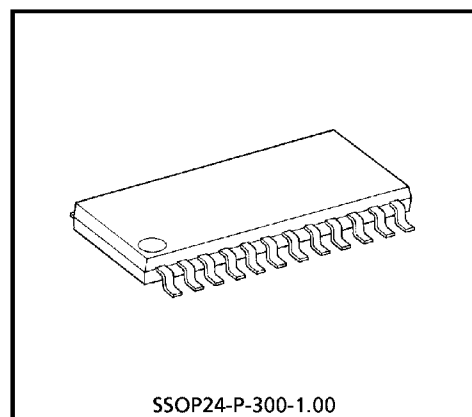

Weight : 0.32g (Typ.)

961001EBA1

- TOSHIBA is continually working to improve the quality and the reliability of its products. Nevertheless, semiconductor devices in general can malfunction or fail due to their inherent electrical sensitivity and vulnerability to physical stress. It is the responsibility of the buyer, when utilizing TOSHIBA products, to observe standards of safety, and to avoid situations in which a malfunction or failure of a TOSHIBA product could cause loss of human life, bodily injury or damage to property. In developing your designs, please ensure that TOSHIBA products are used within specified operating ranges as set forth in the most recent products specifications. Also, please keep in mind the precautions and conditions set forth in the TOSHIBA Semiconductor Reliability Handbook.
- The products described in this document are subject to foreign exchange and foreign trade control laws.
- The information contained herein is presented only as a guide for the applications of our products. No responsibility is assumed by TOSHIBA CORPORATION for any infringements of intellectual property or other rights of the third parties which may result from its use. No license is granted by implication or otherwise under any intellectual property or other rights of TOSHIBA CORPORATION or others.
- The information contained herein is subject to change without notice.

BLOCK DIAGRAM

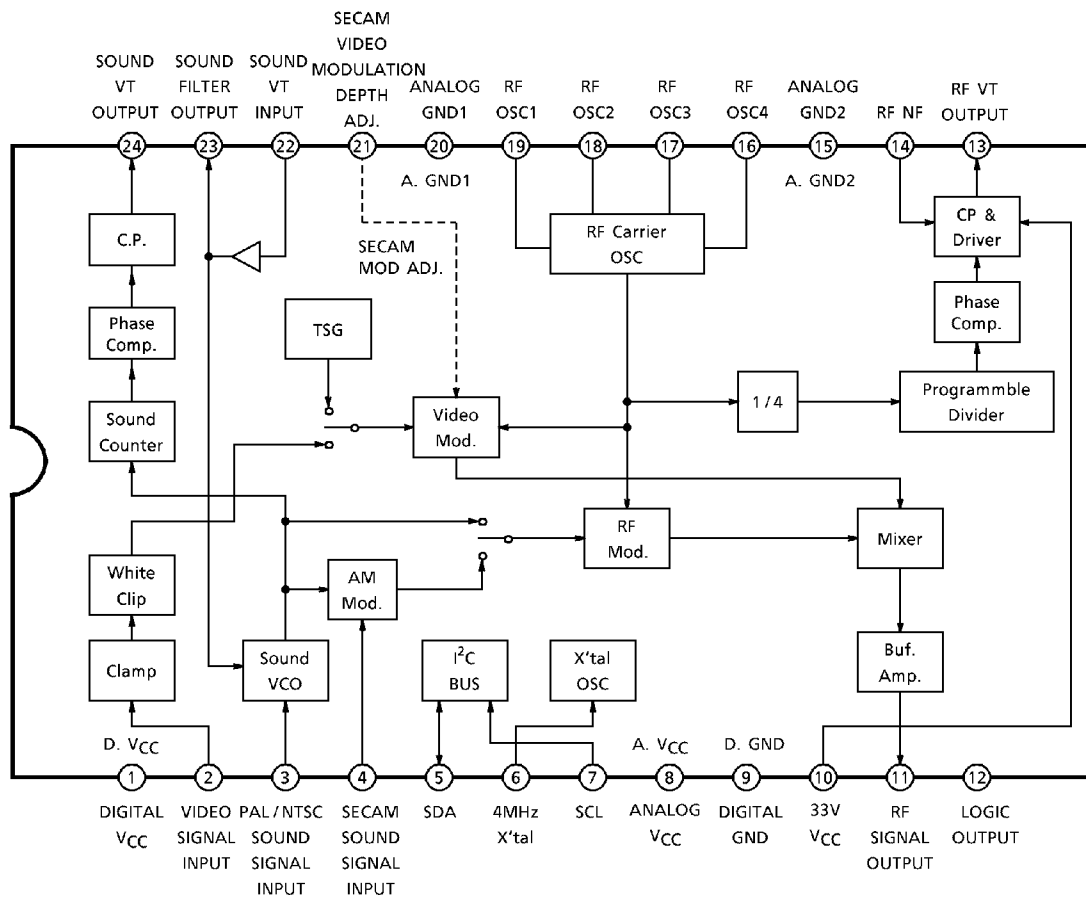

**TERMINAL CHARACTERISTICS** ( $V_{CC1} = 5.0V$ ,  $V_{CC2} = 33V$ ,  $T_a = 25^\circ C$ )

PIN No.	FUNCTION	TYP. DC VOLTAGE	TYP. AC VOLTAGE	INTERFACE	NOTE
1	Digital $V_{CC}$	(5.0V)	—	—	—
2	Video Signal Input	2.4V (Sync TIP)	0.5V <sub>p-p</sub>		Sync TIP clamp input
3	PAL/NTSC Sound Signal Input	0V	200mV <sub>p-p</sub>		
4	SECAM Sound Signal Input	0V	200mV <sub>p-p</sub>		
5	SDA	OPEN BASE	5V <sub>p-p</sub>		I <sup>2</sup> C BUS serial data
6	4MHz X'tal	2.7V	—		
7	SCL	OPEN BASE	5V <sub>p-p</sub>		I <sup>2</sup> C BUS serial clock

PIN No.	FUNCTION	TYP. DC VOLTAGE	TYP. AC VOLTAGE	INTERFACE	NOTE
8	Analog VCC	(5.0V)	—	—	Analog power supply
9	Digital GND	(0V)	—	—	Digital ground
10	VCC33	33V	—	—	Tuning voltage power supply
11	RF Signal Output	3.8V	80dB $\mu$ V (Picture)		
12	Logic Output	H : 4.3V L : 0V	—		BUS control I <sub>Max</sub> = 10mA
13	RF V <sub>T</sub> Output	—	—		Tuning voltage output
14	RF NF	—	—		
15	Analog GND2	(0V)	—	—	Analog ground
16	RF OSC4	3.4V	—		
17	RF OSC3	3.4V			
18	RF OSC2	3.4V			
19	RF OSC1	3.4V			

PIN No.	FUNCTION	TYP. DC VOLTAGE	TYP. AC VOLTAGE	INTERFACE	NOTE
20	Analog GND1	(0V)	—	—	Analog ground
21	SECAM Video Modulation depth Adj.	3.1V	—		<p>Possible to adjustment by the outside resistance. Resistance is inserted between VCC and 21 pin : Modulation depth decreases</p> <p>Resistance is inserted between GND and 21 pin : Modulation depth increases</p>
22	Sound VT Input	—	—		
23	Sound Filter Output	—	—		
24	Sound VT Output	—	—		

**I<sup>2</sup>C-BUS DATA FORMAT**

		MSB							LSB	ACK
Address Byte	ADR	1	1	0	0	1	0	1	0	ACK
Control Byte1	C1	1	(*)	(*)	(*)	PS2	PS1	PS0	LE	ACK
Control Byte2	C2	WO	PSA	LO	FA1	FA0	(*)	(*)	(*)	ACK
Prog. Data Byte1	PD1	0	TSG	N10	N9	N8	N7	N6	N5	ACK
Prog. Data Byte2	PD2	N4	N3	N2	N1	0	1	0	0	ACK

(\*) Don't care

Bus data transmission : ADR + C1 + C2 + PD1 + PD2 or  
 ADR + PD1 + PD2 + C1 + C2 or  
 ADR + C1 + C2 or  
 ADR + PD1 + PD2

- PS2~PS0 : Picture to sound ratio setting (Video signal input : Stair case (B/W) 0.5V<sub>p-p</sub>  
 Sound signal input : 1kHz sin wave 0.2V<sub>p-p</sub>)

PS RATIO (SYSTEM L)	PS RATIO (OTHER THAN SYSTEM L)	PS2	PS1	PS0
-6dB	-10dB	0	0	0
-7dB	-11dB	0	0	1
-8dB	-12dB	0	1	0
-9dB	-13dB	0	1	1
-10dB	-14dB	1	0	0
-11dB	-15dB	1	0	1
-12dB	-16dB	1	1	0
-13dB	-17dB	1	1	1

- LE : System L enable

- 1 ... This mode is SYSTEM L. Positive modulation for video and AM modulation for sound inter carrier at 6.5MHz.  
 In this case, FA1 and FA2 don't care.
- 0 ... Modes other than SYSTEM L. Negative modulation for video and FM modulation for sound inter carrier at 4.5MHz, 5.5MHz, 6.0MHz, 6.5MHz.  
 The system is selected by FA1 and FA2.

- WO : Control of white clip

- 1 ... White clip off. The system L is used, and the characteristic of 100% modulations can be evaluated.
- 0 ... White clip on.

## 4. PSA : Control of power save

1 ... Power save off. (normal operation)

0 ... Power save on. Becomes waiting for the bus data.

And power supplies other than the bus decoder are turned off.

The data of the decoder is maintained while  $V_{CC}$  is added.When  $V_{CC}$  is turned off, power on reset changes the data of the decoder by turning on  $V_{CC}$  again.

## 5. LO : Control of logic out

1 ... 12 pin become high voltage.

0 ... 12 pin become low voltage.

## 6. FA1~FA0 : Sound Inter Carrier Frequencies setting

FA1	FA0	SOUND INTER CARRIER FREQUENCY	FREQUENCY DEVIATION
0	0	4.5MHz	$\pm 25\text{kHz}$
0	1	5.5MHz	$\pm 50\text{kHz}$
1	0	6.0MHz	$\pm 50\text{kHz}$
1	1	6.5MHz	$\pm 50\text{kHz}$

## 7. TPSG : Control of test pattern signal generator

1 ... ON

0 ... OFF (normal operation)

## 8. N10~N1 : Programmable Divider Data setting

The frequency of VCO is calculated by the next expression.

$$f_{VCO} = 31.25\text{kHz} \times 32 \times N + 250\text{kHz}$$

$$N = 512 \times N_{10} + 256 \times N_9 + 128 \times N_8 + 64 \times N_7 + 32 \times N_6 + 16 \times N_5 + 8 \times N_4 + 4 \times N_3 + 2 \times N_2 + N_1$$

The frequency step is 1MHz, and 250kHz is given in the IC.

The divider data N is made frequency  $-250\text{kHz}$  of the set channel.

**POWER ON RESET MODE**

Power on reset functions when the power supply is turned on.

The decoder data is the data of power on reset until the bus data is received.

In this mode, because the power saving is turned on, the RF signal is not output.

- VCO Frequency Setting : 591.25MHz (CCIR 36ch)
- Television System : System G (Sound carrier frequency : 5.5MHz,  
FM deviation :  $\pm 50$ kHz,  
Video modulation polarity : negative modulation)
- P/S Ratio Set Up : - 13dB
- White Clip : ON
- Power Save : ON
- Logic Output : LOW
- TPSG : OFF

		MSB							LSB	ACK
Address Byte	ADR	1	1	0	0	1	0	1	0	ACK
Control Byte1	C1	1	(*)	(*)	(*)	0	1	1	0	ACK
Control Byte2	C2	0	0	0	0	1	(*)	(*)	(*)	ACK
Prog. Data Byte1	PD1	0	0	1	0	0	1	0	0	ACK
Prog. Data Byte2	PD2	1	1	1	1	0	1	0	0	ACK

(\*) Don't care



**MAXIMUM RATINGS (Ta = 25°C)**

CHARACTERISTIC	SYMBOL	RATING	UNIT
Supply Voltage 5V System	V <sub>CC1</sub>	8	V
Supply Voltage 33V System	V <sub>CC2</sub>	35	V
Power Dissipation 1 (Note 1)	P <sub>D1</sub>	595	mW
Power Dissipation 2 (Note 2)	P <sub>D2</sub>	830	mW
Input Terminal Voltage	V <sub>IN</sub>	GND - 0.3 ~ V <sub>CC</sub> + 0.3	V
Operating Temperature	T <sub>opr</sub>	-20 ~ 75	°C
Storage Temperature	T <sub>stg</sub>	-55 ~ 150	°C

(Note 1) Derated linearly above Ta = 25°C in the proportion of 4.8mW/°C.

(Note 2) On the board mounting (Glass epoxy 50 × 50 × 1.6mm, Area of copper : 30%)  
Derated linearly above Ta = 25°C in the proportion of 6.7mW/°C.

Please note the product design of the board because the calorific value is large.

- The copper area is widened.
- Hole for heat radiation of shield case.
- Other enough consideration.

**RECOMMENDED OPERATING CONDITION**

CHARACTERISTIC	SYMBOL	MIN.	TYP.	MAX.	UNIT
Supply Voltage 5V System	V <sub>CC1</sub>	4.5	5	5.5	V
Supply Voltage 33V System	V <sub>CC2</sub>	27	33	35	V

**ELECTRICAL CHARACTERISTICS** ( $V_{CC1} = 5.0V$ ,  $V_{CC2} = 33V$ ,  $T_a = 25^\circ C$ ,  $f_p = 591.25MHz$ )

	No.	CHARACTERISTIC	SYMBOL	TEST CIR-CUIT	MIN.	TYP.	MAX.	UNIT	NOTE
Whole	1-1	Supply Current 1 (A.V <sub>CC</sub> + D.V <sub>CC</sub> )	I <sub>CC1</sub>	—	45	62	80	mA	Power supply of 5V part
	1-2	Supply Current 2 (A.V <sub>CC</sub> + D.V <sub>CC</sub> )	I <sub>CC2</sub>	—	4	6	8	mA	5V power supply of power save
	1-3	Supply Current 3 (V <sub>CC</sub> 33V)	I <sub>CC3</sub>	—	2.0	2.5	3.5	mA	Power supply of 33V part
	1-4	Operating Frequency Range	f <sub>op</sub>	—	471.25	—	855.25	MHz	f <sub>p</sub> frequency
Video Part	2-1-1	Video RF Output Level (Negative Modulation)	V <sub>on</sub> (f <sub>p</sub> )	—	78	81	84	dB <sub>μ</sub> V	50Ω Termination STAIR CASE (B / W) signal : 0.5V <sub>p-p</sub> input
	2-1-2	Video RF Output Level (Positive Modulation)	V <sub>op</sub> (f <sub>p</sub> )						
	2-2-1	Video modulation Depth (Negative Modulation)	mpn	—	75	79	83	%	WHITE signal : 0.5V <sub>p-p</sub> input
	2-2-2	Video modulation Depth (Positive Modulation)	mpp	—	85	89	93		
	2-3-1	White Clipping Level (Negative Modulation)	mpn (MAX)	—	90	94	98	%	WHITE signal : 1.0V <sub>p-p</sub> input
	2-3-2	White Clipping Level (Positive Modulation)	mpp (MAX)	—	210	240	—		DG / DP : 5% / 5°, WHITE CLIP : OFF
	2-4-1	Differential Gain (Negative Modulation)	DGn	—	—	±3	±5	%	STAIR CASE : 0.5V <sub>p-p</sub> (chrominance signal 20IRE)
	2-4-2	Differential Gain (Positive Modulation)	DGp						

No.	CHARACTERISTIC	SYMBOL	TEST CIRCUIT	MIN.	TYP.	MAX.	UNIT	NOTE	
Video Part	2-5-1	Differential Phase (Negative Modulation)	DPn	—	—	± 3	± 5	°	STAIR CASE : 0.5V <sub>p-p</sub> (Chrominance signal 20IRE)
	2-5-2	Differential Phase (Positive Modulation)	DPp						
	2-6-1	Video S/N Ratio (Negative Modulation)	mpn (S/N)	—	51	53	—	dB	0.1~5MHz, Unweighting, WHITE 50% signal input
	2-6-2	Video S/N Ratio (Positive Modulation)	mpp (S/N)						
	2-7-1	Video Frequency Response (Negative Modulation)	f <sub>pn</sub>	—	—	± 1	± 2	dB	0.1~5MHz 1MHz Reference
	2-7-2	Video Frequency Response (Positive Modulation)	f <sub>pp</sub>						
	2-8	Average Picture Level Drift	mp (APL)	—	—	± 0.5	± 3.0	%	APL 10-90%, 50% Reference
	2-9	Sync Crush Level	Δ <sub>sync</sub>	—	—	1	3	%	{1 - (V <sub>sync</sub> / V <sub>white</sub> ) × (100 / 40)}
	2-10-1	Chroma Beat (Negative Modulation)	V <sub>cn</sub>	—	—	- 75	- 70	dB	4.43MHz sin wave : 0.5V <sub>p-p</sub> input, Video carrier level reference, P/S = - 13dB
	2-10-2	Chroma Beat (Positive Modulation)	V <sub>cp</sub>						
	2-11-1	RF Carrier 2'nd Harmonic Level	V <sub>2fp</sub>	—	—	- 28	- 20	dB	Reference = Video carrier level
	2-11-2	RF Carrier 3'rd Harmonic Level	V <sub>3fp</sub>						
	2-12	Video Signal 2nd Harmonic Level	V <sub>pH</sub>	—	—	- 55	- 50	dB	1MHz sin wave : 0.5V <sub>p-p</sub> input, fp + 1MHz Reference, fp + 2MHz measurement
	2-13-1	Prescaller Spurious (fp × 1 / 2)	V <sub>PR1/2</sub>	—	—	0	10	dB <sub>μV</sub>	—
2-13-2	Prescaller Spurious (fp × 3 / 2)	V <sub>PR3/2</sub>							
2-14-1	Video Carrier Frequency Accuracy	Δ <sub>fp</sub>	—	—	—	± 100	kHz	X'tal series capacitor : 7pF	

	No.	CHARACTERISTIC	SYMBOL	TEST CIRCUIT	MIN.	TYP.	MAX.	UNIT	NOTE	
TPSG Part	3-1-1	TPSG Modulation Depth (Negative Modulation)	mpn (TPSG)	—	64	74	84	%	TPSG mode	
	3-1-2	TPSG Modulation Depth (Positive Modulation)	mpp (TPSG)		82	92	97			
	3-2	TPSG V/S Ratio	V/S		2.0	2.4	2.8	—		
	3-3-1	TPSG Horizontal Sync Signal Cycle	Tsync	—	62	64	66	$\mu$ s		
	3-3-2	TPSG Horizontal Sync Signal Width	Wsync		3.6	4.0	4.4			
	3-4-1	TPSG SYNC-1'st Signal Time	W1		22	24	26			
	3-4-2	TPSG SYNC-2'nd Signal Time	W2		38	40	42			
Sound Part	4-1	P/S Ratio	Rp/S	—	-15	-13	-11	dB	Set in -13dB by bus, STAIR CASE (B/W) signal : 0.5V <sub>p-p</sub> input	
	4-2-1	Range of P/S Ratio	FM	—	-17	—	-10	dB	P/S ratio can be adjusted by 1dB. 1kHz sin wave input : 0.2V <sub>p-p</sub> (AM)	
	4-2-2	Range of P/S Ratio	AM	—	-13	—	-6			
	4-3-1	Sound Modulation Sensitivity	FM1 (5.5MHz/6.0MHz/6.5MHz)	$\beta_{FM1}$	—	0.558	0.62	0.682	kHz/mV	1kHz sin wave : 0.2V <sub>p-p</sub> input, $\beta_{FM}$ = $\Delta f$ (kHz) / 200 (mV)
	4-3-2	Sound Modulation Sensitivity	FM2 (4.5MHz)	$\beta_{FM2}$	—	0.279	0.31	0.341	kHz/mV	
4-3-3	Sound Modulation Sensitivity	AM	$\beta_{AM}$	—	56.7	63	69.3	%	1kHz sin wave : 0.2V <sub>p-p</sub> input	

No.	CHARACTERISTIC	SYMBOL	TEST CIR-CUIT	MIN.	TYP.	MAX.	UNIT	NOTE	
Sound Part	4-4-1	Sound S / N Ratio FM1 (5.5MHz / 6.0MHz / 6.5MHz)	S / N (FM1)	—	50	55	—	dB 1kHz sin wave input : ± 50kHz dev. = 0dB Inter Carrier demod., de-emph = IN, Colorbar signal : 0.5V <sub>p-p</sub> input	
	4-4-2	Sound S / N Ratio FM2 (4.5MHz)	S / N (FM2)	—	47	52	—		1kHz sin wave input : ± 25kHz dev. = 0dB Inter Carrier demod., de-emph = IN, Colorbar signal : 0.5V <sub>p-p</sub> input
	4-4-3	Sound S / N Ratio AM	S / N (AM)	—	50	55	—		1kHz sin wave input : 60% mod. = 0dB de-emph = IN, Colorbar signal : 0.5V <sub>p-p</sub> input
	4-5-1	Sound Distortion FM	THD (FM)	—	—	0.25	0.5	% 1kHz sin wave : ± 50 (25) kHz dev. 1kHz sin wave : 60% MOD.	
	4-5-2	Sound Distortion AM	THD (AM)	—					
	4-6-1	Sound Frequency Response FM	f <sub>s</sub> (FM)	—	—	± 1	± 2	dB 100Hz~20kHz, 1kHz reference	
	4-6-2	Sound Frequency Response AM	f <sub>s</sub> (AM)	—	—	± 0.5	± 1		
	4-7-1	Sound 2'nd Harmonic Level	V <sub>SH1</sub>	—	—	- 65	- 60	dB P / S ratio = - 13dB, Video carrier level reference	
	4-7-2	Sound 3'rd Harmonic Level	V <sub>SH2</sub>	—	—	- 75	- 70		
	4-8	Sound Inter-Carrier Frequency Accuracy	Δf <sub>s</sub>	—	—	—	± 750	Hz X'tal series capacitor : 7pF	

	No.	CHARACTERISTIC	SYMBOL	TEST CIR-CUIT	MIN.	TYP.	MAX.	UNIT	NOTE
Logic part	5-1	LOW Level Input Voltage of Both SDA and SCL Lines	$V_L$	—	0	—	1.8	V	—
	5-2	HIGH Level Input Voltage of Both SDA and SCL Lines	$V_H$	—	2.8	—	$V_{CC}$	V	—
	5-3	LOW Level Output Voltage of SDA Line	$V_{ACK}$	—	0	—	0.4	V	at 3mA sink current During the acknowledge clock pulse
	5-4	Threshold Voltage of Power On Reset	$V_{RESET}$	—	2.0	2.8	3.6	V	—
	5-5	Logic Out Current	$I_{LOGIC}$	—	—	—	10	mA	Mounts on the board of power dissipation 830mW. $T_a$ (MAX) = 75°C
—	6-1	Negative Resistance of X'tal Oscillator	$R_{XO}$	—	-1	—	—	k $\Omega$	—

**INPUT WAVE FORM**

WHITE SIGNAL

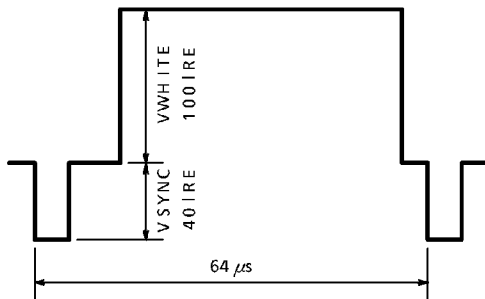

STAIRCASE (B/W) SIGNAL  
APL50%

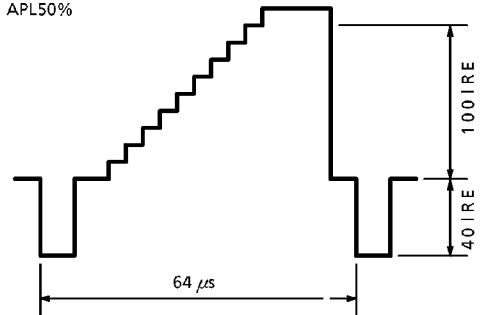

STAIRCASE SIGNAL (Sub-carrier 20IRE)  
APL50%

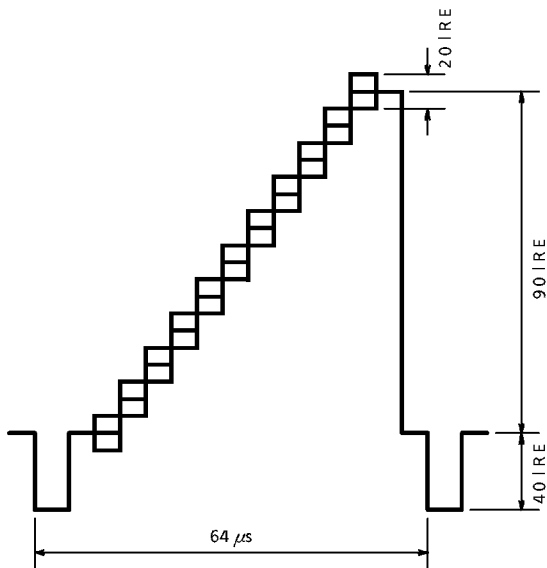

**DATA TRANSFER ON THE I<sup>2</sup>C-BUS**

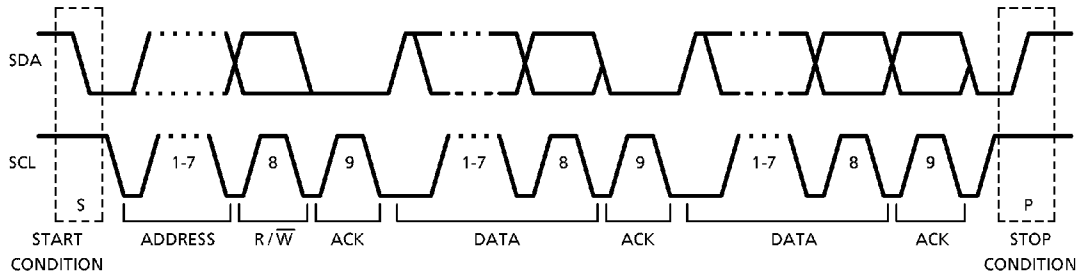

**TIMING REQUIREMENTS FOR THE I<sup>2</sup>C-BUS**

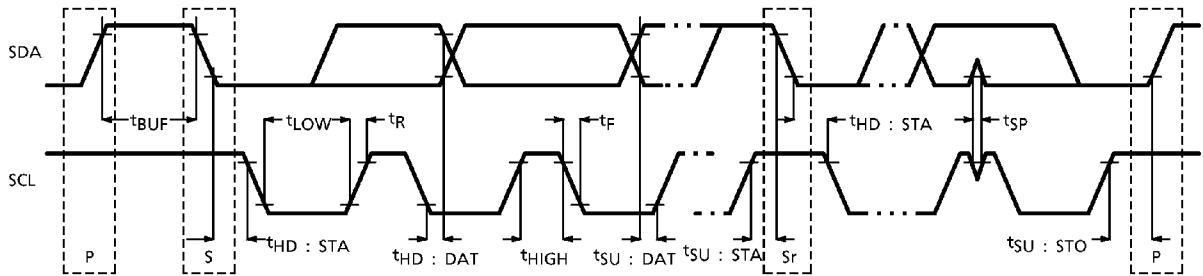



APPLICATION CIRCUIT

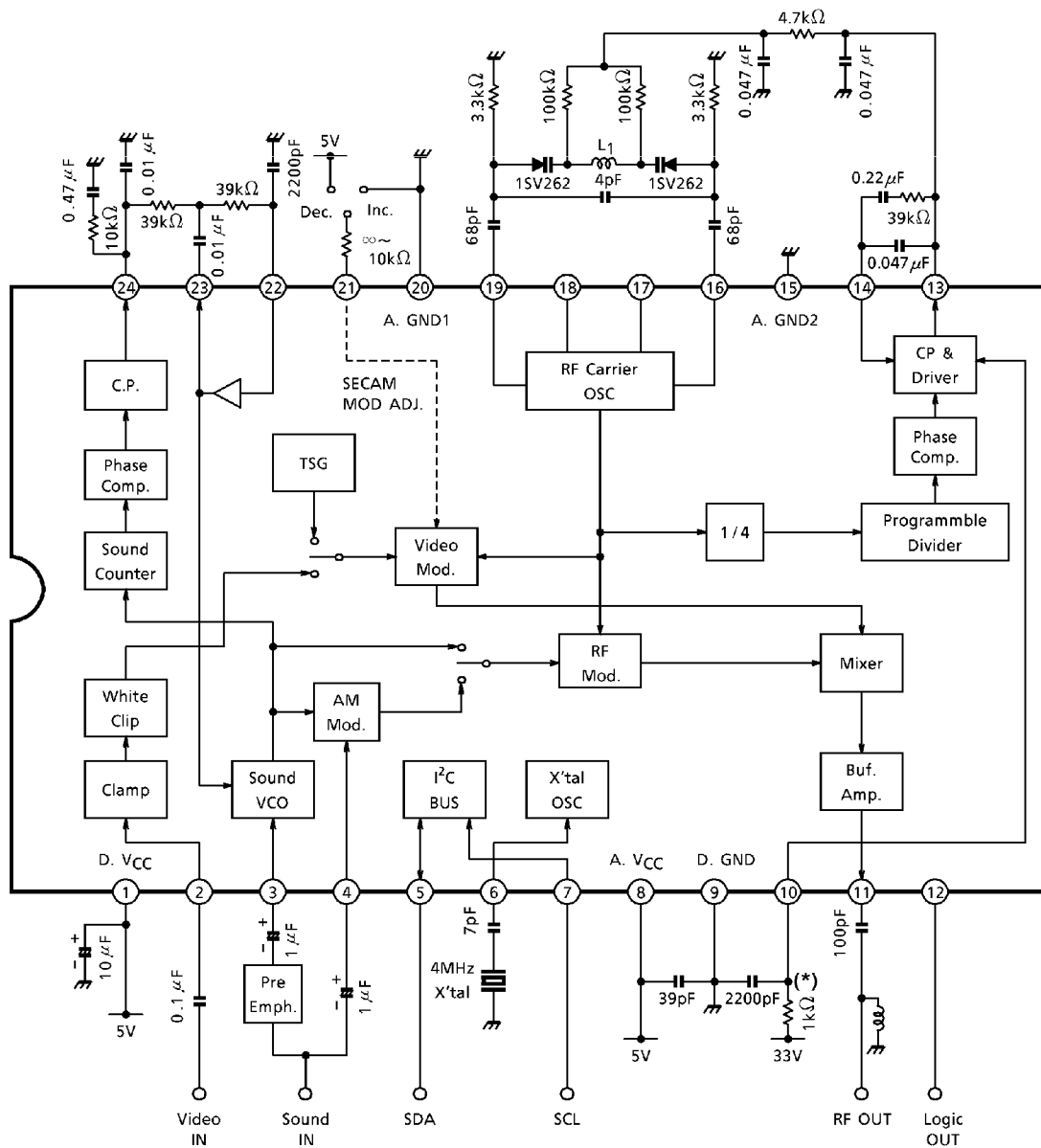

L<sub>1</sub> : Coil Diameter 3.2mm, Wire Diameter 0.4mm, 2.5 turns.  
 (\*) : Protection resistance for prevention of overshoot.

**OUTLINE DRAWING**  
SSOP24-P-300-1.00

Unit : mm

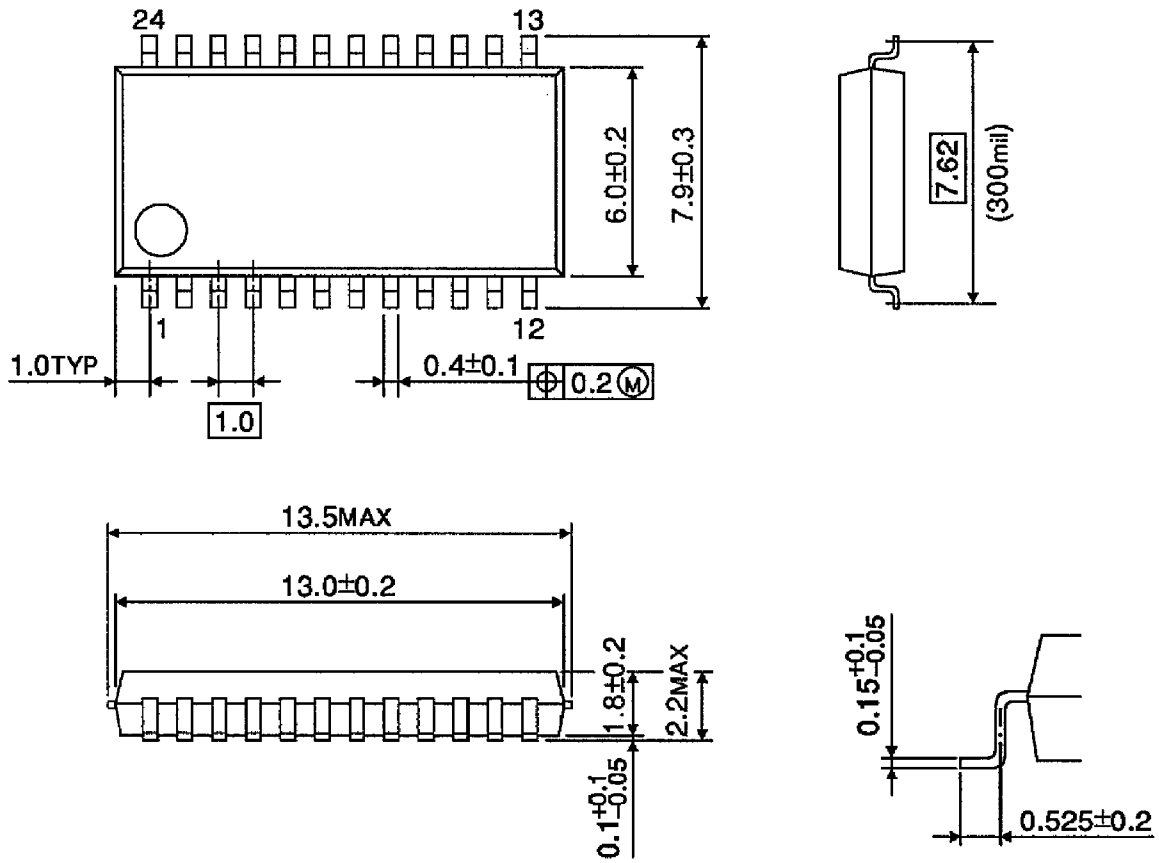

Weight : 0.32g (Typ.)