

# HIGH SPEED LAN MAGNETICS

960028A

- Transmit side module, includes impedance matched common mode termination
- Designed for use with a variety of 10/100 and 100 Mbps PHY transceiver chipsets
- Combine with any 1:1 receive transformer designed for high speed 100 Mbps or 10/100 Mbps applications
- Cost efficient, miniature surface mount package rated to 225°C peak IR reflow temperature

## ELECTRICALS AT 25°C

Part No.	Inductance	Insertion Loss	Return Loss		Hipot (Vrms) Min
	OCL (µH) Min with 8mA DC Bias	(dB) Max 1MHz-100MHz	100kHz-60MHz	60MHz-80MHz	
S558-5999-63	350	-1.0	-18	-12	2000

## SCHEMATIC

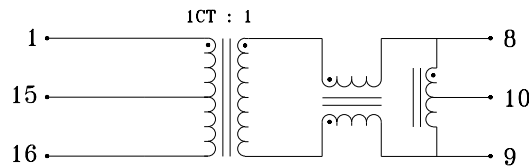

## MECHANICAL

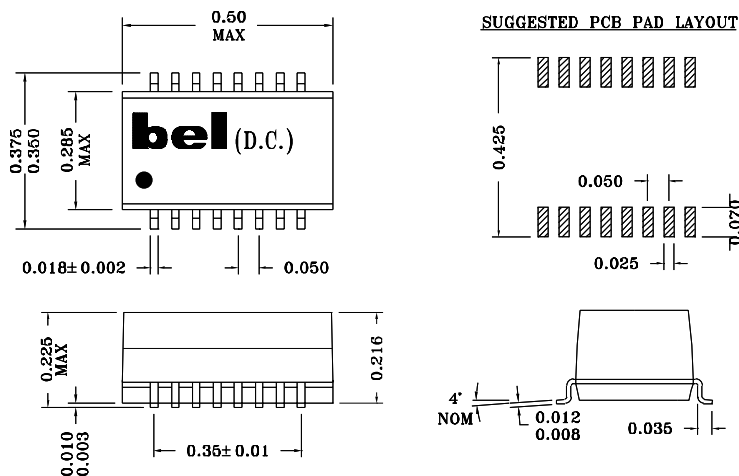

Specifications subject to change without notice.

960028A

### APPLICATION CIRCUIT

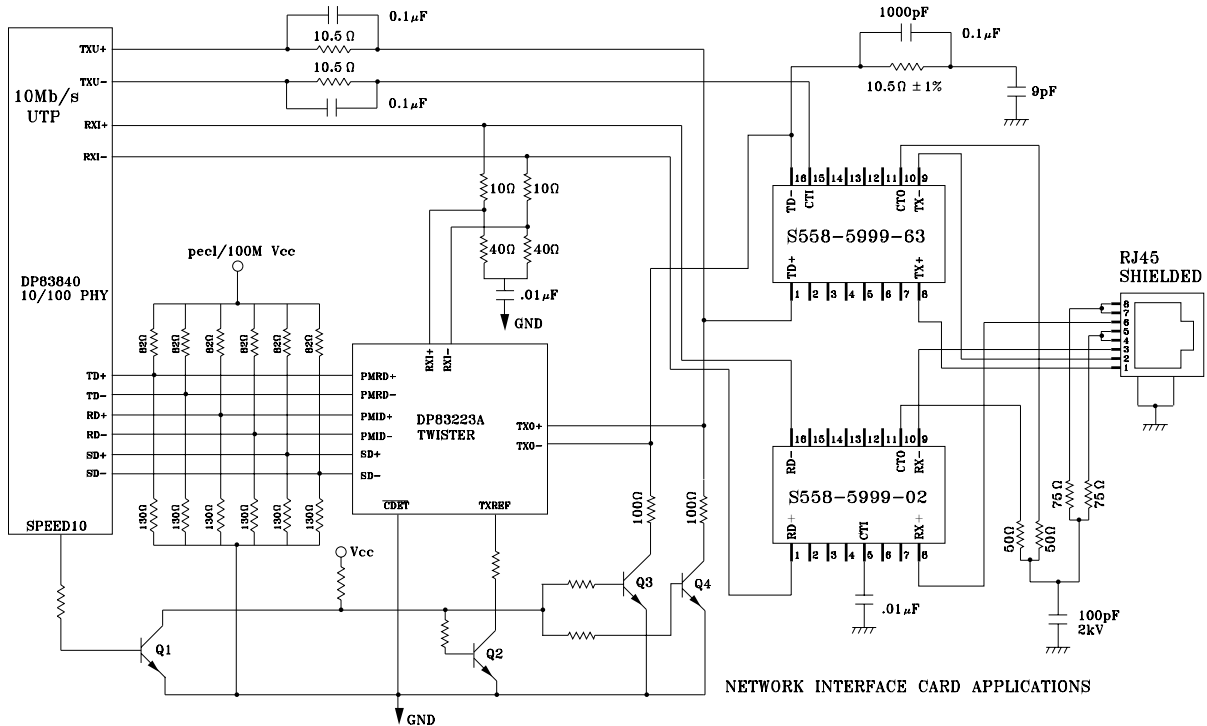

### APPLICATION NOTES

- Refer to Bel's short form catalog to determine compatibility of this part with the recommended transceivers.
- This part is designed to include an additional core with terminated center tap following the primary transformer to create an impedance matched signal. Careful consideration should be provided in choosing the externally placed, discrete components which will affect proper functionality. Refer to Bel's separate application note on the proper use of the impedance matched common mode termination.
- Bel's low profile, surface mount packaging is ideal for high speed pick and place machinery. Parts can be shipped on tape and reel for high speed placement. Construction processes have been implemented for thermal compatibility with high temperature IR reflow assembly processing. Post dipping of leads assist with PC board solderability. Each part is optically inspected to meet rigid coplanarity requirements.
- Refer to data sheet 960025 for details on S558-5999-02.

#### Corporate Office

**Bel Fuse Inc.**  
198 Van Vorst Street, Jersey City, NJ 07302-4496  
Tel: 201-432-0463  
Fax: 201-432-9542  
E-Mail: [BelFuse@belfuse.com](mailto:BelFuse@belfuse.com)  
Internet: <http://www.belfuse.com>

#### Far East Office

**Bel Fuse Ltd.**  
8F/8 Luk Hop Street  
San Po Kong  
Kowloon, Hong Kong  
Tel: 852-2328-5515  
Fax: 852-2352-3706

#### European Office

**Bel Fuse Europe Ltd.**  
Preston Technology Management Centre  
Marsh Lane, Preston PR1 8UD  
Lancashire, U.K.  
Tel: 44-1772-556601  
Fax: 44-1772-888366