

## ■ Features

- Colorless transparency lens type
- $\phi 3\text{mm(T-1)}$  all plastic mold type
- High luminosity

## ■ Outline dimensions

(unit : mm)

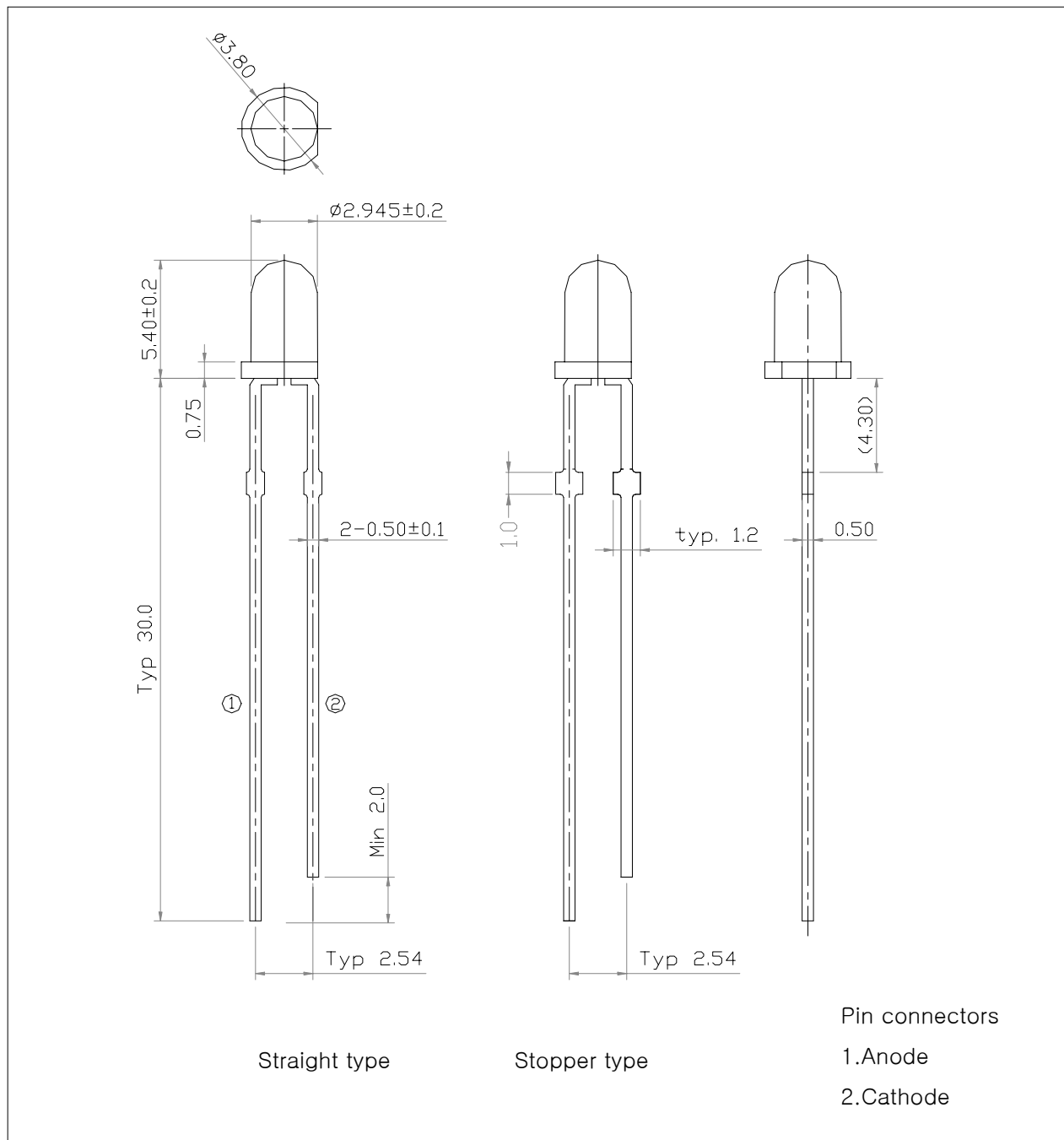

## ■ Absolute maximum ratings

Characteristic	Symbol	Ratings	Unit
Power dissipation	$P_D$	120	mW
Forward Current	$I_F$	30	mA
* <sup>1</sup> Peak Forward Current	$I_{FP}$	100	mA
Reverse Voltage	$V_R$	5	V
Operating Temperature	$T_{opr}$	-30~85	°C
Storage Temperature	$T_{stg}$	-40~100	°C
* <sup>2</sup> Soldering Temperature	$T_{sol}$	260°C for 3 seconds	

\*1. Duty ratio 1/10, Pulse Width 10msec

\*2. Keep the distance more than 2.0mm from PCB to the bottom of LED package

## ■ Electrical – Optical Characteristics

(Ta=25°C)

Characteristic	Symbol	Test Condition	Min.	Typ.	Max.	Unit
Forward Voltage	$V_F$	$I_F=20\text{mA}$	-	2.1	2.7	V
Dominant Wavelength	$\lambda_p$	$I_F=20\text{mA}$	-	592	-	nm
Spectrum Bandwidth	$\Delta\lambda$	$I_F=20\text{mA}$	-	15	-	nm
Reverse Current	$I_R$	$V_R=5\text{V}$	-	-	10	uA
* <sup>3</sup> Half Angle	$\theta_{1/2}$	$I_F=20\text{mA}$	-	$\pm 17$	-	deg

\*3.  $\theta_{1/2}$  is the off-axis angle where the luminous intensity is 1/2 the peak intensity

## ■ Luminous intensity ranks

(Ta=25°C)

Iv RANK	Test Condition	Min.	Typ.	Max.	Unit
P	I <sub>F</sub> = 20mA	1200	–	1700	mcd
Q		1700	–	2400	
R		2400	–	3400	
S		3400	–	4800	

\* Luminous intensity is tested at a current pulse duration of 25 ms and an accuracy of ±11%.

Intensity Measured : 0.01sr(CIE. LED\_B)

## ■ Precautions On LED using

\* To avoid optical difference, Please do not mix differently-ranked product.

■ Characteristic Diagrams

Fig.1 IF - VF

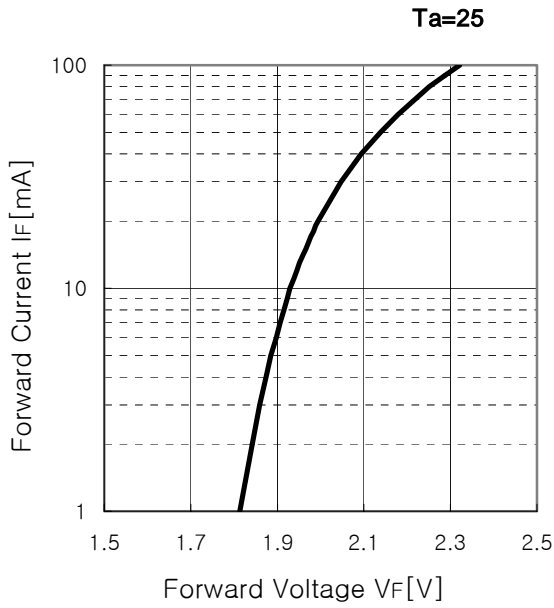

Fig.2 Iv - IF

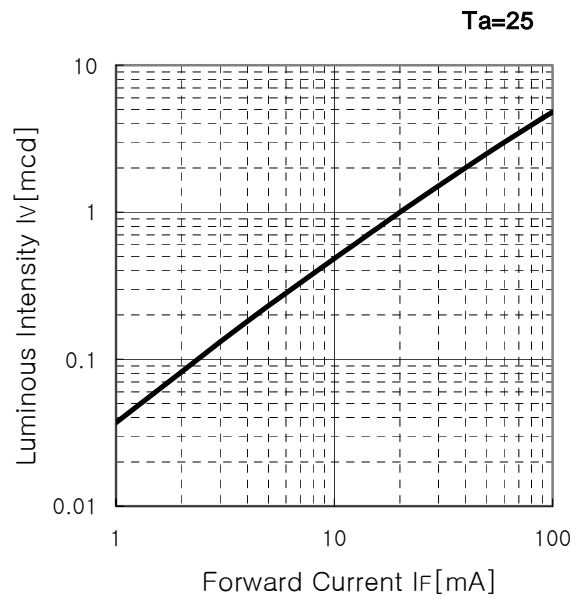

Fig.3 Max. Permissible Forward Current

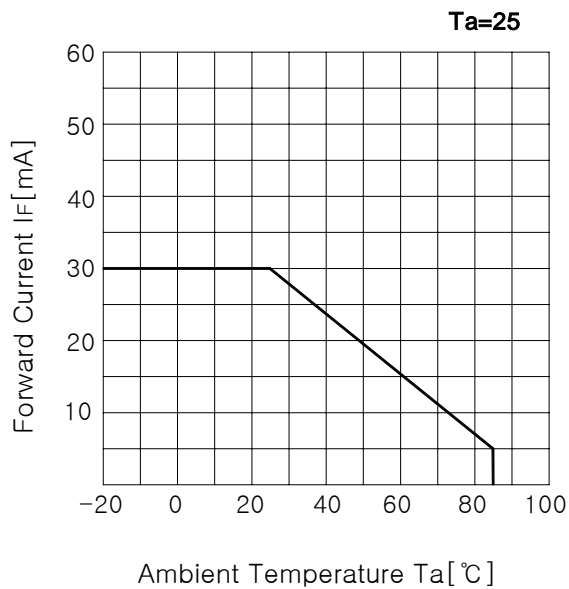

Fig.4 Relative Intensity - Ta

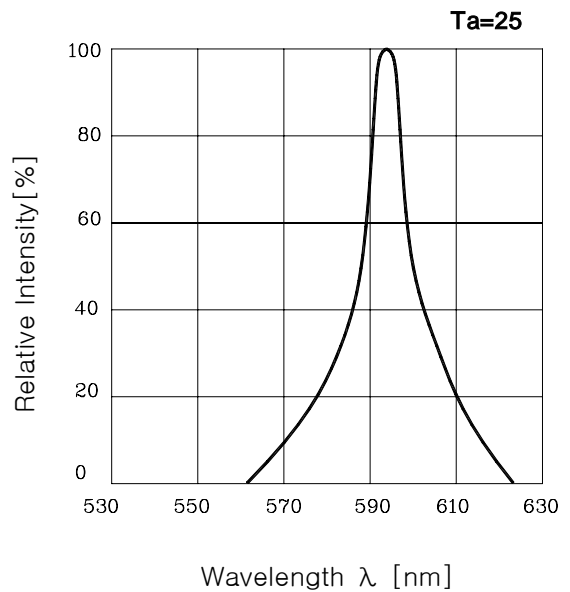
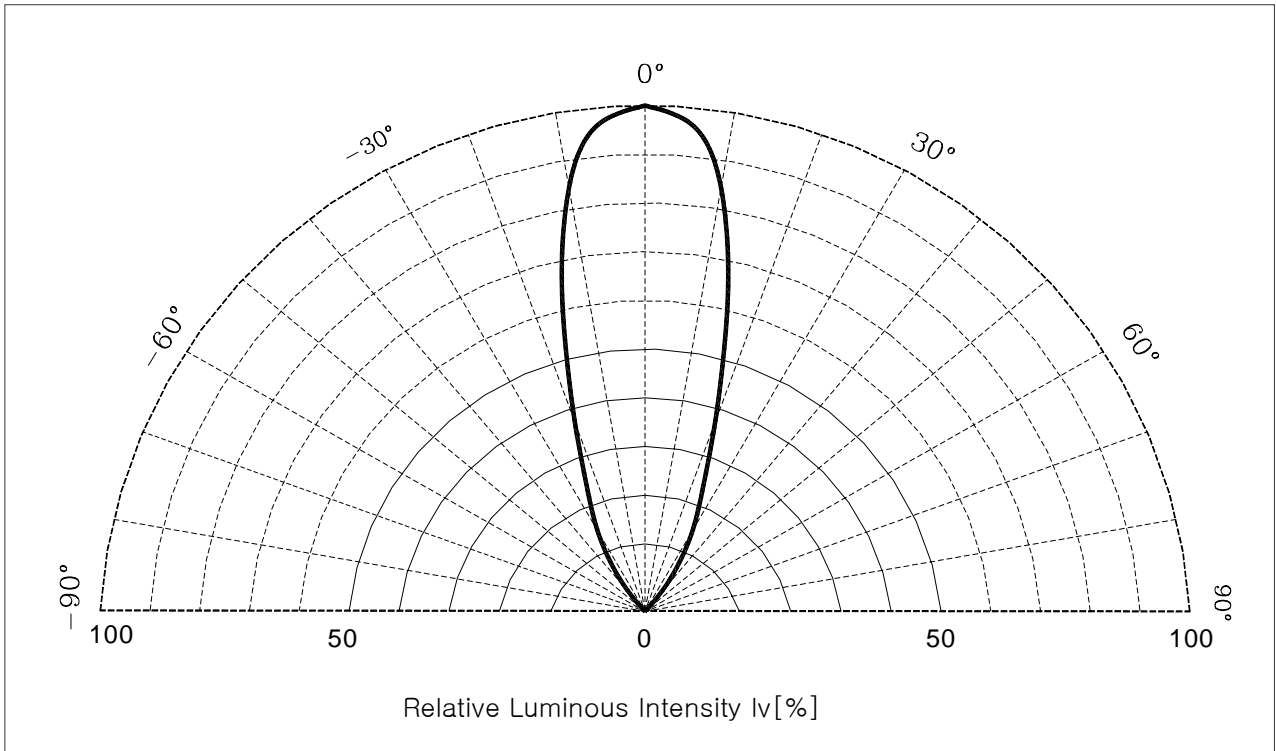

Fig. 5 Radiation Diagram



■ Revision history sheet

Spec NO.			
Title	Specification for Approval		
Times	Date	Summary of revision	Remarks
1	2001. 07. 15	신규제정	
2	2003. 02. 26	Format 변경	
3	2004. 06. 03	lv Rank 변경	