

ADSL Magnetics

For Analog Devices AD20MSP910

- Designed to meet UL 1950 and EN60950 safety requirements for supplementary insulation at 250V
- UL file number E150991
- Minimum interwinding breakdown voltage of 1500 Vrms
- CO and CPE applications require two each of the S560-6600-30 or 0560-6600-63
- Operating temperature range: -40° C to +85° C
- Meets IEC 695, 2-2 flammability requirements
- PWB Process Capability: standard printed wiring board assembly techniques, total-immersion cleaning
- Reliability testing: shock, vibration, temperature cycling, temperature - humidity - bias

ELECTRICAL SPECIFICATIONS AT 25° C

Part Number	Package	Turns Ratio ± 2%	Inductance ¹ mH ±10%	Leakage Inductance ² µH max	DCR Ω Max		Interwinding Capacitance ³	Longitudinal Balance ⁴ db min	Insertion Loss ⁴ dB max	Frequency Response ⁴ dB	Harmonic Distortion ⁴ dB max
		Chip : Line	Chip Side	Chip Side	Chip Side	Line Side	pF max	10 kHz - 1.1 MHz	300 kHz	30 kHz - 1.1 MHz	30 kHz 4Vrms
S560-6600-30	SMD	1 : 1	5	16.5	4	4	60	46	0.5	± 0.5	-80
0560-6600-63	THT	1 : 1	5	16.5	4	4	60	46	0.5	± 0.5	-80

All measurements are made with pins 2 and 3 connected and pins 8 and 9 connected

1. Inductance measured at 10kHz, 0.1 Vac

2. Leakage inductance measured at 100kHz, 0.1 Vac

3. Interwinding capacitance measured at 1kHz, 1 Vac

4. Measurements made with 100Ω source and 100Ω load impedance.

SCHEMATIC

S560-6600-30
0560-6600-63

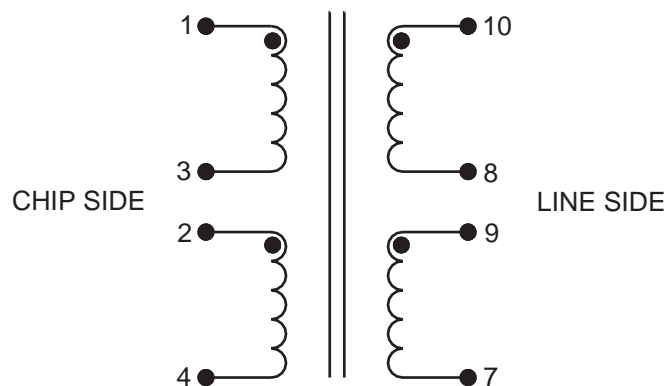

TM00302

MECHANICAL

S560-6600-30

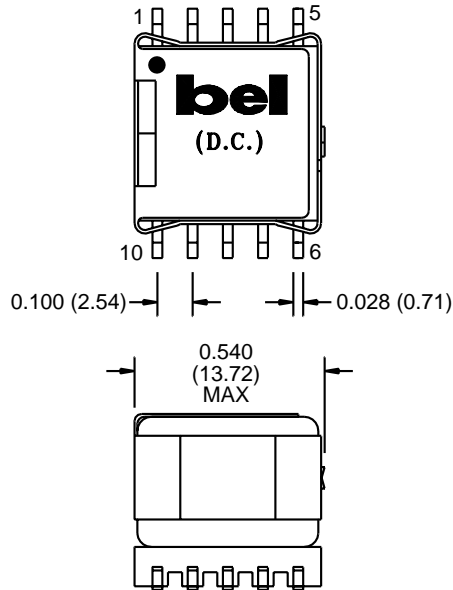

SUGGESTED PCB PAD LAYOUT

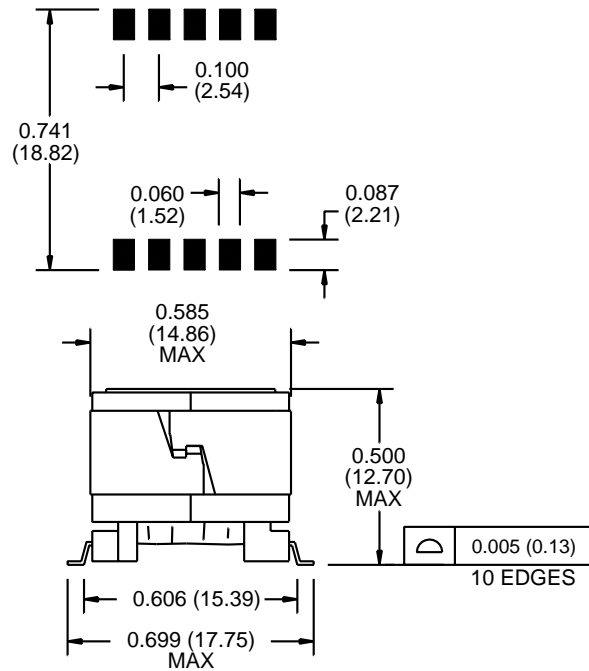

0560-6600-63

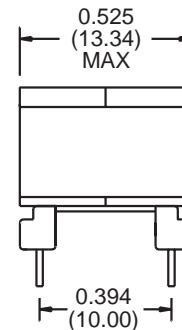
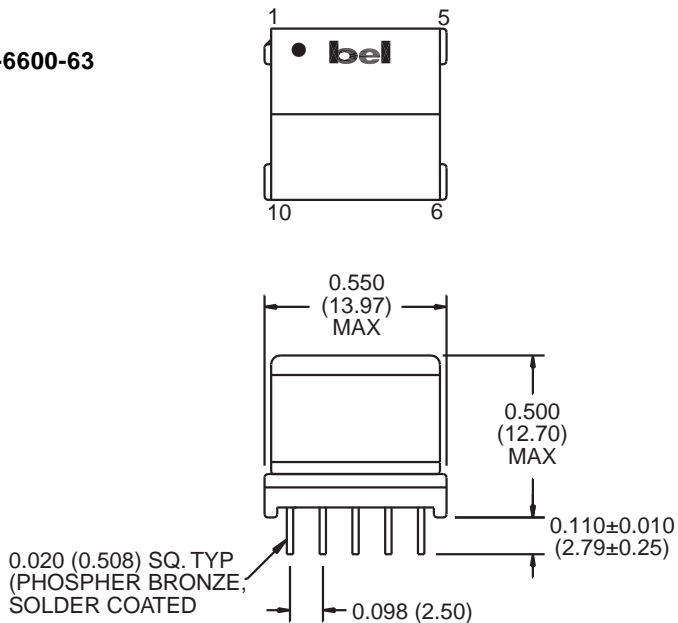

©2001 Bel Fuse Inc. Specifications subject to change without notice. 02.01

CORPORATE

Bel Fuse Inc.
198 Van Vorst Street
Jersey City, NJ 07302
Tel 201-432-0463
Fax 201-432-9542
www.belfuse.com

FAR EAST

Bel Fuse Ltd.
8F / 8 Luk Hop Street
San Po Kong
Kowloon, Hong Kong
Tel 852-2328-5515
Fax 852-2352-3706
www.belfuse.com

EUROPE

Bel Fuse Europe Ltd.
Preston Technology Management Centre
Marsh Lane, Suite G7, Preston
Lancashire, PR1 8UD, U.K.
Tel 44-1772-556601
Fax 44-1772-888366
www.belfuse.com