

CZT853
SURFACE MOUNT
HIGH CURRENT
SILICON NPN TRANSISTOR

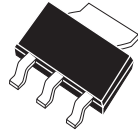

SOT-223 CASE

CentralTM

Semiconductor Corp.

DESCRIPTION:

The CENTRAL SEMICONDUCTOR CZT853 type is a high current NPN silicon transistor manufactured by the epitaxial planar process, epoxy molded in a surface mount package, designed for high voltage and high current amplifier applications.

MARKING CODE: FULL PART NUMBER

PNP complement: CZT953

MAXIMUM RATINGS: ($T_A=25^\circ\text{C}$)

	SYMBOL		UNITS
Collector-Base Voltage	V_{CBO}	200	V
Collector-Emitter Voltage	V_{CEO}	100	V
Emitter-Base Voltage	V_{EBO}	6.0	V
Collector Current	I_C	6.0	A
Power Dissipation	P_D	3.0	W (Note 1)
Operating and Storage			
Junction Temperature	T_J, T_{stg}	-65 to +150	$^\circ\text{C}$
Thermal Resistance	θ_{JA}	41.7	$^\circ\text{C/W}$

ELECTRICAL CHARACTERISTICS: ($T_A=25^\circ\text{C}$ unless otherwise noted)

SYMBOL	TEST CONDITIONS	MIN	TYP	MAX	UNITS
I_{CBO}	$V_{CB}=150\text{V}$			10	nA
I_{CER}	$V_{CE}=150\text{V}, R_{BE} \leq 1\text{k}\Omega$			10	nA
I_{CBO}	$V_{CB}=150\text{V}, T_A=100^\circ\text{C}$			1.0	μA
I_{EBO}	$V_{EB}=6.0\text{V}$			10	nA
BV_{CBO}	$I_C=100\mu\text{A}$	200	220		V
BV_{CER}	$I_C=10\text{mA}, R_{BE} \leq 1\text{k}\Omega$	200	210		V
BV_{CEO}	$I_C=10\text{mA}$	100	110		V
BV_{EBO}	$I_E=100\mu\text{A}$	6.0	8.0		V
$V_{CE(SAT)}$	$I_C=100\text{mA}, I_B=5\text{mA}$		22	50	mV
$V_{CE(SAT)}$	$I_C=2.0\text{A}, I_B=100\text{mA}$		135	170	mV
$V_{CE(SAT)}$	$I_C=5.0\text{A}, I_B=500\text{mA}$			340	mV
$V_{BE(SAT)}$	$I_C=5.0\text{A}, I_B=500\text{mA}$			1.25	V

Notes: (1) FR-4 Epoxy PC Board with copper mounting pad area of 4in^2 (minimum)

R1 (30-January 2006)

**SURFACE MOUNT
HIGH CURRENT
SILICON NPN TRANSISTOR**

ELECTRICAL CHARACTERISTICS: ($T_A=25^\circ\text{C}$ unless otherwise noted)

SYMBOL	TEST CONDITIONS	MIN	TYP	MAX	UNITS
h_{FE}	$V_{CE}=2.0\text{V}, I_C=10\text{mA}$	100			
h_{FE}	$V_{CE}=2.0\text{V}, I_C=2.0\text{A}$	100	200	300	
h_{FE}	$V_{CE}=2.0\text{V}, I_C=4.0\text{A}$	50	100		
h_{FE}	$V_{CE}=2.0\text{V}, I_C=10\text{A}$	20	30		
f_T	$V_{CE}=10\text{V}, I_C=100\text{mA}, f=50\text{MHz}$		190		MHz
C_{ob}	$V_{CB}=10\text{V}, I_E=0, f=1.0\text{MHz}$		38		pF

SOT-223 CASE - MECHANICAL OUTLINE

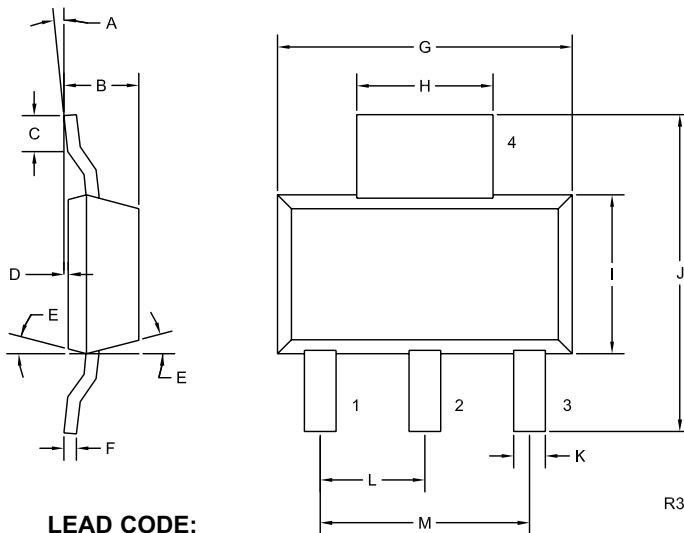

SYMBOL	DIMENSIONS			
	INCHES		MILLIMETERS	
	MIN	MAX	MIN	MAX
A	0°	10°	0°	10°
B	0.059	0.071	1.50	1.80
C	0.018	---	0.45	---
D	0.000	0.004	0.00	0.10
E	15°		15°	
F	0.009	0.014	0.23	0.35
G	0.248	0.264	6.30	6.70
H	0.114	0.122	2.90	3.10
I	0.130	0.146	3.30	3.70
J	0.264	0.287	6.70	7.30
K	0.024	0.033	0.60	0.85
L	0.091		2.30	
M	0.181		4.60	

SOT-223 (REV: R3)

LEAD CODE:

- 1) BASE
- 2) COLLECTOR
- 3) EMITTER
- 4) COLLECTOR

MARKING CODE:

FULL PART NUMBER

R1 (30-January 2006)