

Dual N-Channel Enhancement Mode MOSFET

Features

- SOP-8
20V/6A , $R_{DS(ON)}=19m\Omega(\text{typ.}) @ V_{GS}=4.5V$
 $R_{DS(ON)}=27m\Omega(\text{typ.}) @ V_{GS}=2.5V$
- TSSOP-8
20V/6A , $R_{DS(ON)}=21m\Omega(\text{typ.}) @ V_{GS}=4.5V$
 $R_{DS(ON)}=29m\Omega(\text{typ.}) @ V_{GS}=2.5V$
- Super High Dense Cell Design for Extremely Low $R_{DS(ON)}$
- Reliable and Rugged
- SO-8 and TSSOP-8 Packages

Applications

- Power Management in Notebook Computer , Portable Equipment and Battery Powered Systems.

Pin Description

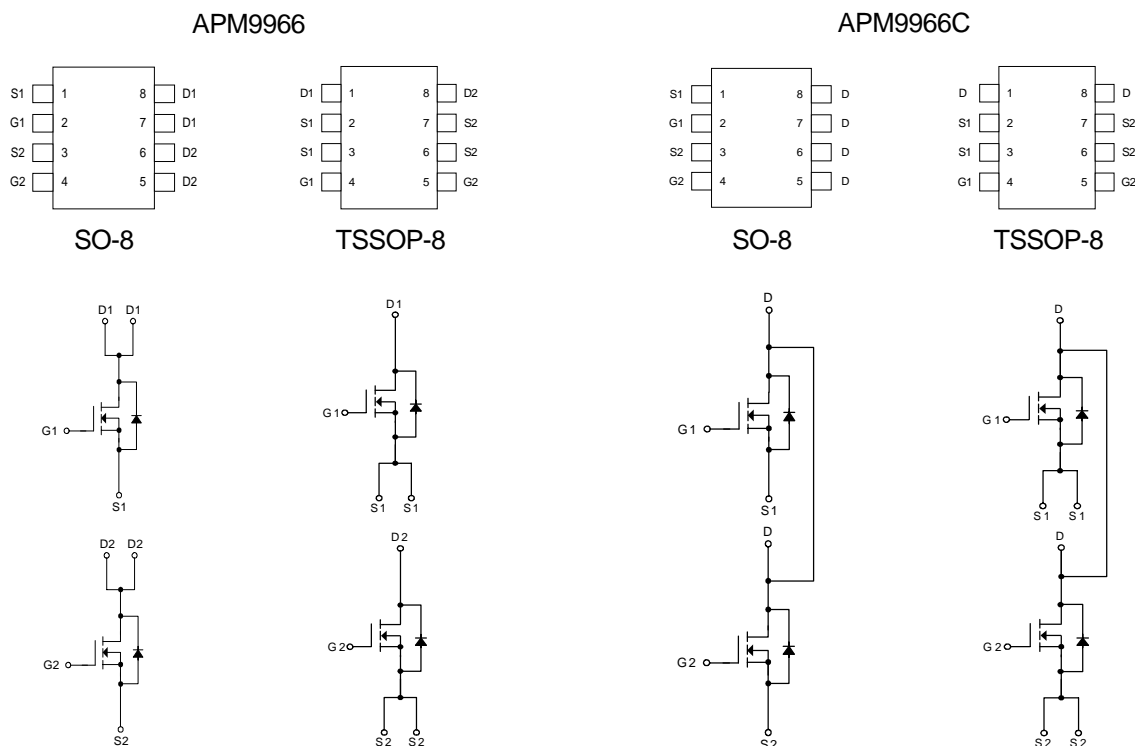

ANPEC reserves the right to make changes to improve reliability or manufacturability without notice, and advise customers to obtain the latest version of relevant information to verify before placing orders.

Ordering and Marking Information

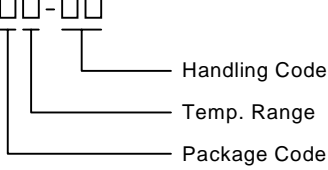
<p>APM9966/C □□-□□</p>  <p>Handling Code Temp. Range Package Code</p>	<p>Package Code K : SO-8 O : TSSOP-8 Operation Junction Temp. Range C : -55 to 150°C Handling Code TR : Tape & Reel</p>
<p>APM9966/C K/O : APM9966/C XXXXX</p>	<p>XXXXX - Date Code</p>

Absolute Maximum Ratings (T_A = 25°C unless otherwise noted)

Symbol	Parameter		Rating	Unit	
V _{DSS}	Drain-Source Voltage		20	V	
V _{GSS}	Gate-Source Voltage		±10		
I _D [*]	Maximum Drain Current – Continuous		6	A	
I _{DM}	Maximum Drain Current – Pulsed		20		
P _D	Maximum Power Dissipation	T _A =25°C	SO-8	1.6	W
			TSSOP-8	1.0	
		T _A =100°C	SO-8	0.625	
			TSSOP-8	0.4	
T _J	Maximum Junction Temperature		150	°C	
T _{STG}	Storage Temperature Range		-55 to 150	°C	
R _{θJA}	Thermal Resistance – Junction to Ambient		50	°C/W	

* Surface Mounted on FR4 Board, t ≤ 10 sec.

Electrical Characteristics (Cont.) ($T_A = 25^\circ\text{C}$ unless otherwise noted)

Symbol	Parameter	Test Condition	APM9966/C			Unit	
			Min.	Typ.	Max.		
Static							
BV_{DSS}	Drain-Source Breakdown Voltage	$V_{GS}=0V, I_{DS}=250\mu A$	20			V	
I_{DSS}	Zero Gate Voltage Drain Current	$V_{DS}=16V, V_{GS}=0V$			1	μA	
$V_{GS(th)}$	Gate Threshold Voltage	$V_{DS}=V_{GS}, I_{DS}=250\mu A$	0.5	0.7	1	V	
I_{GSS}	Gate Leakage Current	$V_{GS}=\pm 10V, V_{DS}=0V$			± 100	nA	
$R_{DS(ON)}^a$	Drain-Source On-state Resistance	SOP-8	$V_{GS}=4.5V, I_{DS}=6A$		19	23	m Ω
			$V_{GS}=2.5V, I_{DS}=5.2A$		27	33	
		TSSOP-8	$V_{GS}=4.5V, I_{DS}=6A$		21	25	
			$V_{GS}=2.5V, I_{DS}=5.2A$		29	35	
V_{SD}^a	Diode Forward Voltage	$I_{SD}=1.7A, V_{GS}=0V$		0.8	1.1	V	
Dynamic^b							
Q_g	Total Gate Charge	$V_{DS}=10V, I_{DS}=1A$ $V_{GS}=4.5V,$		14	18	nC	
Q_{gs}	Gate-Source Charge			3.5			
Q_{gd}	Gate-Drain Charge			2.1			
$t_{d(ON)}$	Turn-on Delay Time	$V_{DD}=10V, I_{DS}=1A,$ $V_{GEN}=4.5V, R_G=0.2\Omega$		25	47	ns	
T_r	Turn-on Rise Time			22	42		
$t_{d(OFF)}$	Turn-off Delay Time			67	122		
T_f	Turn-off Fall Time			36	67		
C_{iss}	Input Capacitance		$V_{GS}=0V$		780		
C_{oss}	Output Capacitance	$V_{DS}=15V$		165			
C_{riss}	Reverse Transfer Capacitance	Frequency=1.0MHz		105			

Notes

- ^a : Pulse test ; pulse width $\leq 300\mu s$, duty cycle $\leq 2\%$
^b : Guaranteed by design, not subject to production testing

Typical Characteristics

Output Characteristics

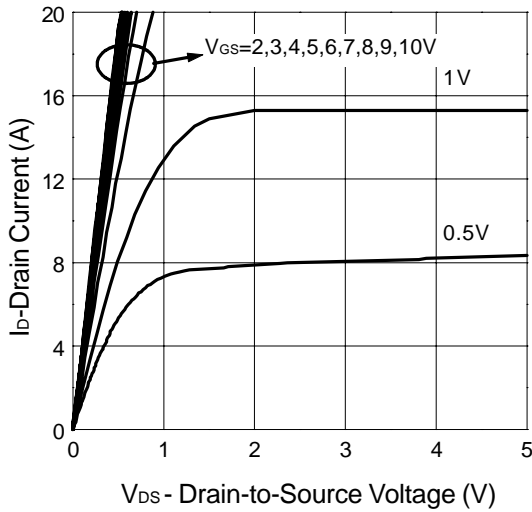

Transfer Characteristics

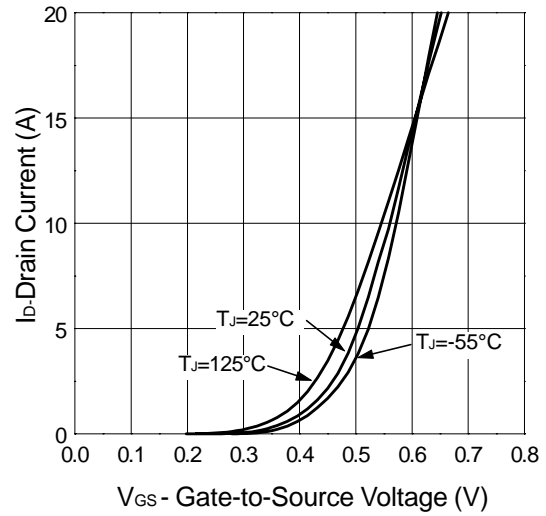

Threshold Voltage vs. Junction Temperature

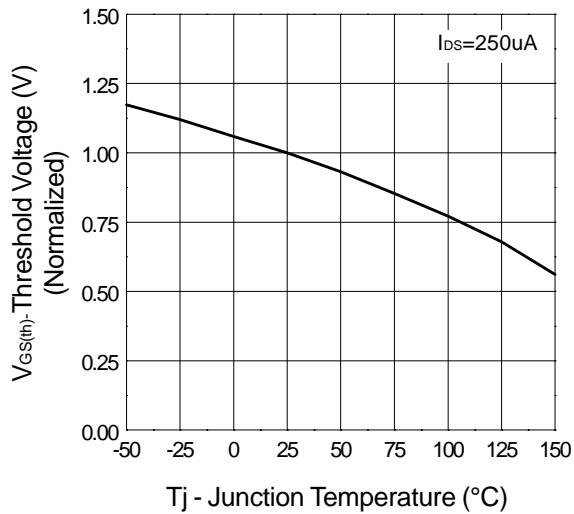

On-Resistance vs. Drain Current
SOP-8

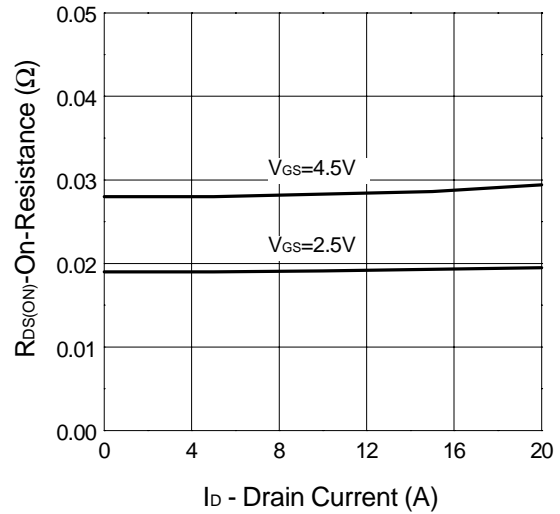

Typical Characteristics (Cont.)

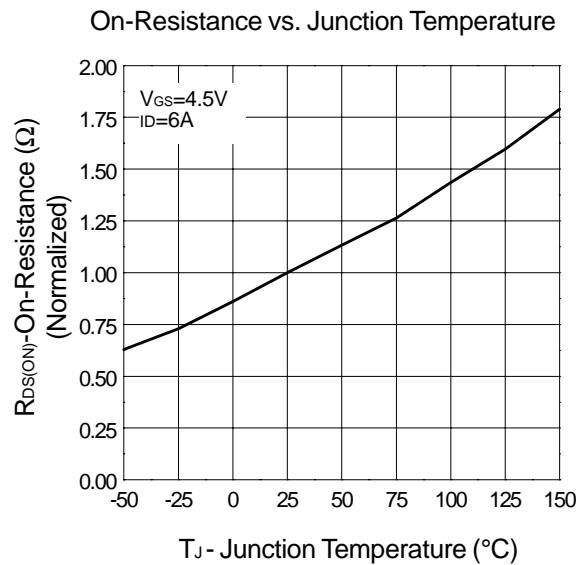
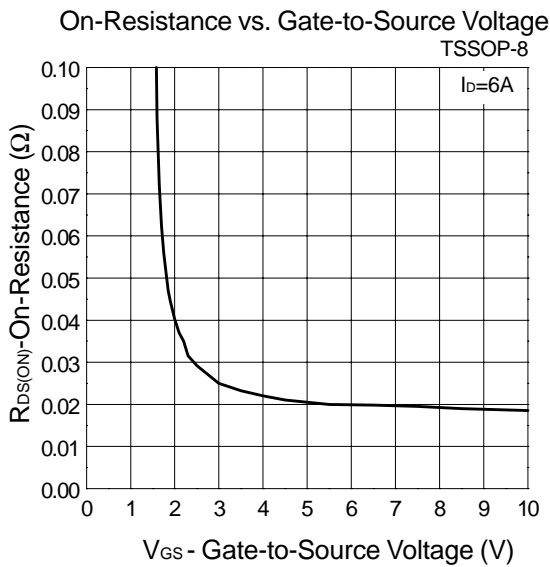
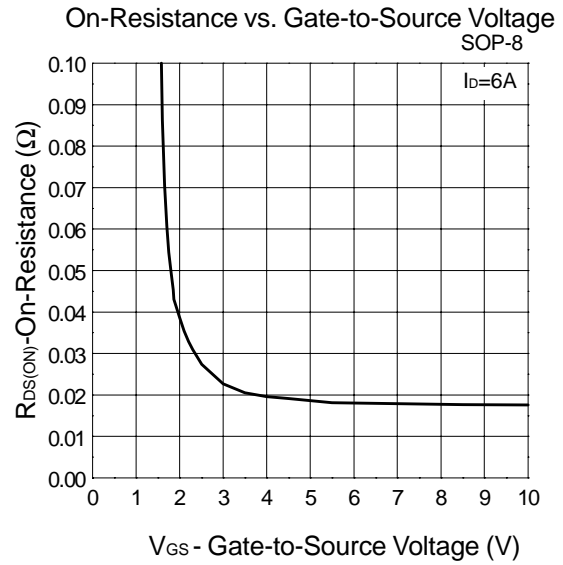
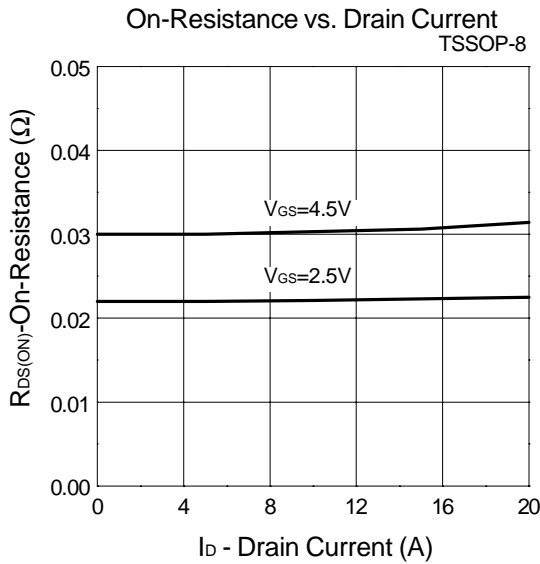

Typical Characteristics (Cont.)

Gate Charge

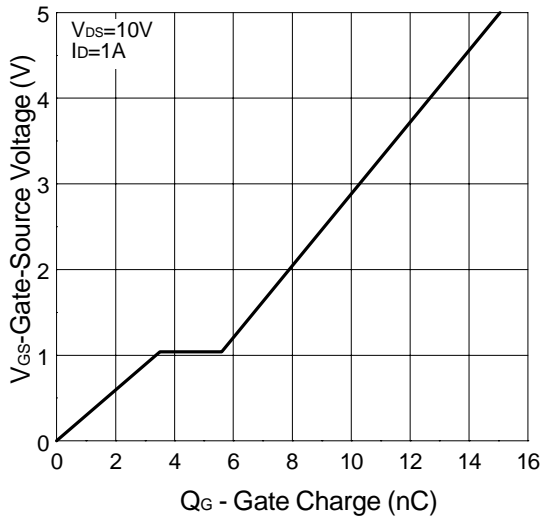

Capacitance

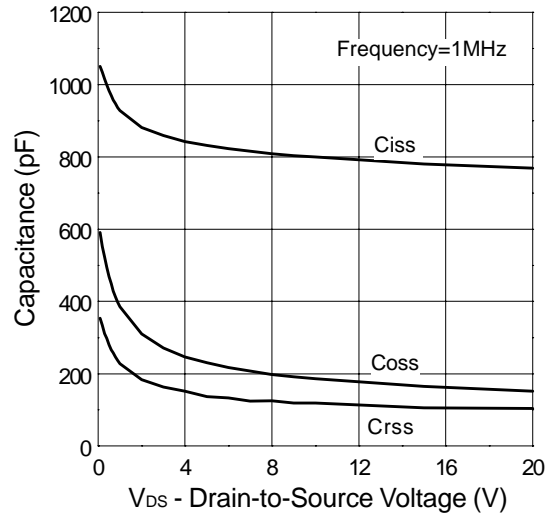

Source-Drain Diode Forward Voltage

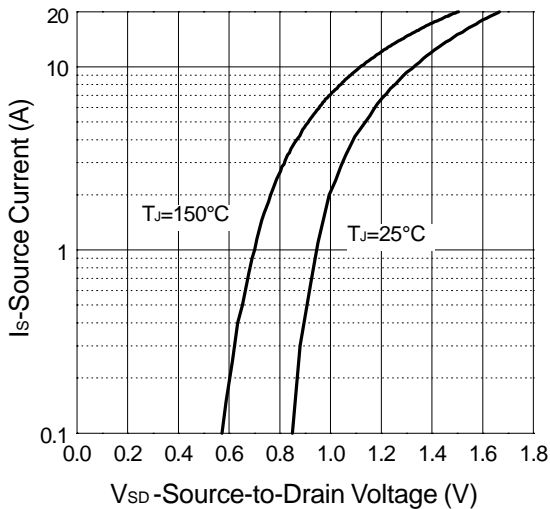

Single Pulse Power

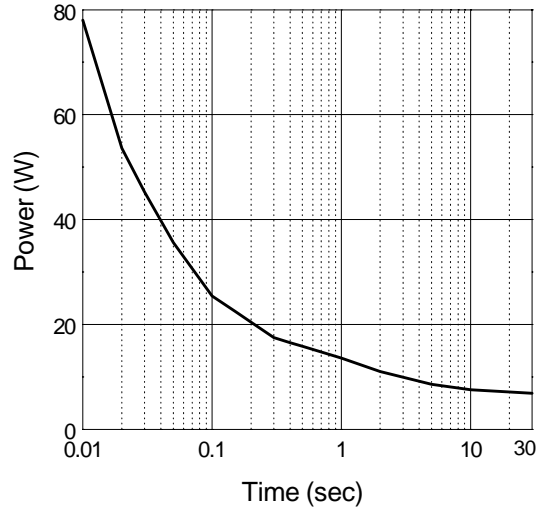

Typical Characteristics (Cont.)

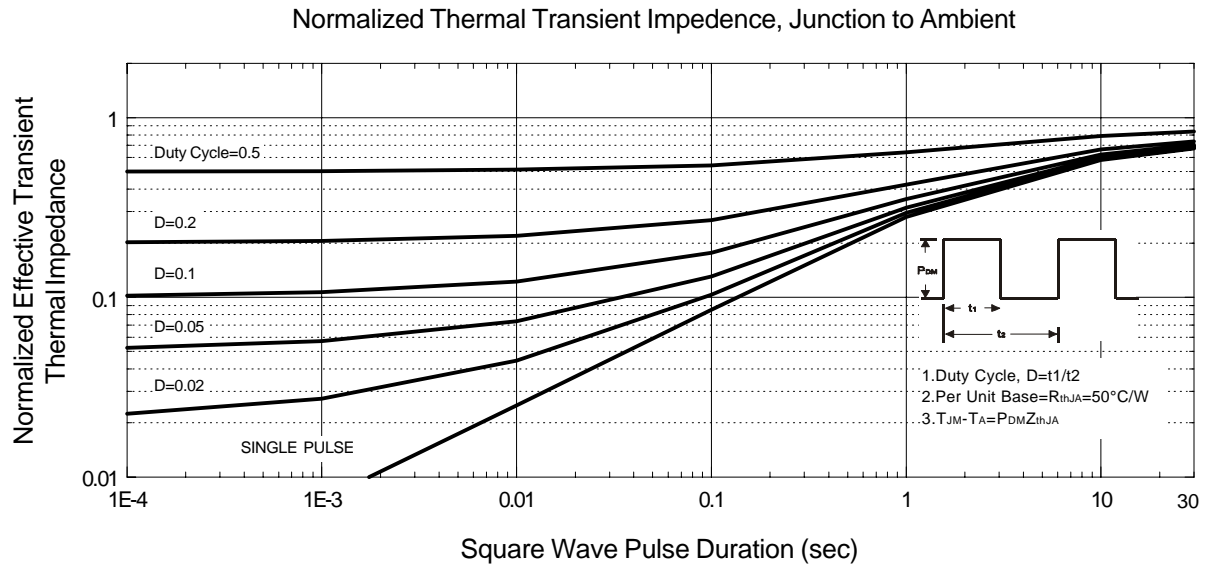

Packaging Information

SOP-8 pin (Reference JEDEC Registration MS-012)

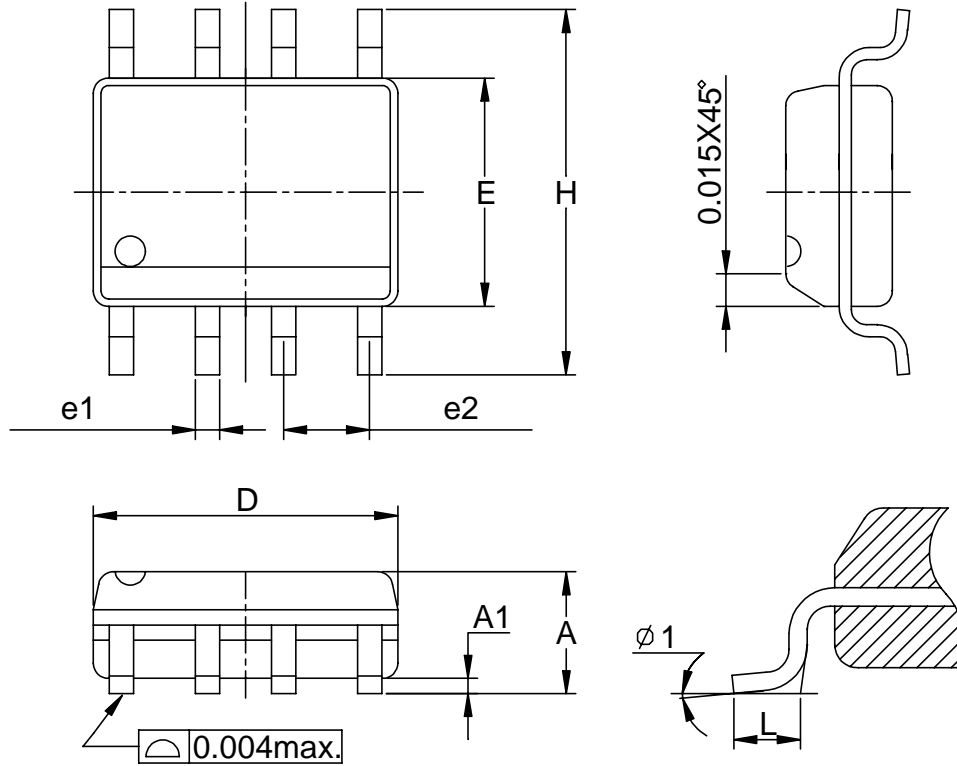

Dim	Millimeters		Inches	
	Min.	Max.	Min.	Max.
A	1.35	1.75	0.053	0.069
A1	0.10	0.25	0.004	0.010
D	4.80	5.00	0.189	0.197
E	3.80	4.00	0.150	0.157
H	5.80	6.20	0.228	0.244
L	0.40	1.27	0.016	0.050
e1	0.33	0.51	0.013	0.020
e2	1.27BSC		0.50BSC	
φ 1	8°		8°	

Packaging Information (Cont.)

TSSOP-8

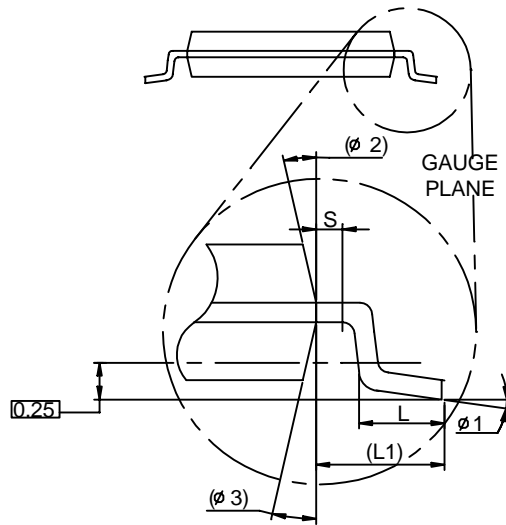
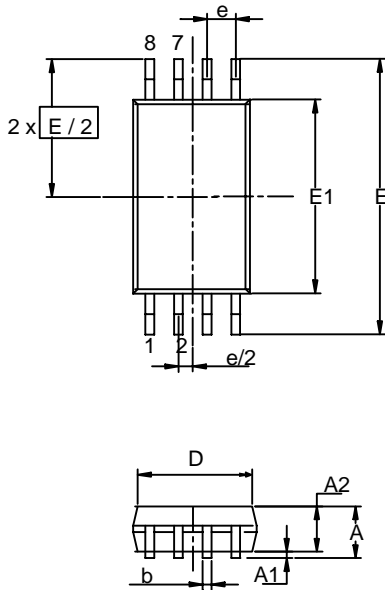

Dim	Millimeters		Inches	
	Min.	Max.	Min.	Max.
A		1.2		0.047
A1	0.00	0.15	0.000	0.006
A2	0.80	1.05	0.031	0.041
b	0.19	0.30	0.007	0.012
D	2.9	3.1	0.114	0.122
e	0.65 BSC		0.026 BSC	
E	6.40 BSC		0.252 BSC	
E1	4.30	4.50	0.169	0.177
L	0.45	0.75	0.018	0.030
L1	1.0 REF		0.039REF	
R	0.09		0.004	
R1	0.09		0.004	
S	0.2		0.008	
$\phi 1$	0°	8°	0°	8°
$\phi 2$	12° REF		12° REF	
$\phi 3$	12° REF		12° REF	

Physical Specifications

Terminal Material	Solder-Plated Copper (Solder Material : 90/10 or 63/37 SnPb)
Lead Solderability	Meets EIA Specification RSI86-91, ANSI/J-STD-002 Category 3.

Reflow Condition (IR/Convection or VPR Reflow)

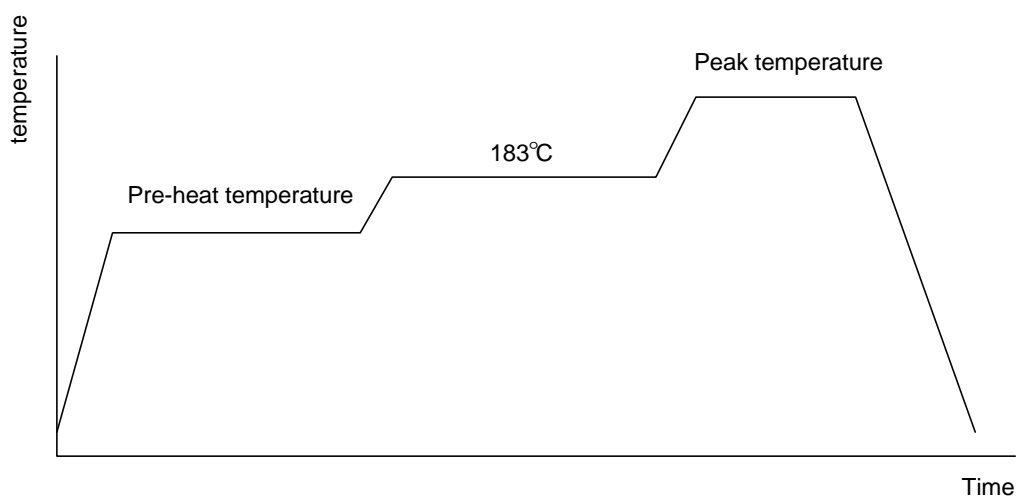

Classification Reflow Profiles

	Convection or IR/ Convection	VPR
Average ramp-up rate(183°C to Peak)	3°C/second max.	10 °C /second max.
Preheat temperature 125 ± 25°C)	120 seconds max	
Temperature maintained above 183°C	60 – 150 seconds	
Time within 5°C of actual peak temperature	10 –20 seconds	60 seconds
Peak temperature range	220 +5/-0°C or 235 +5/-0°C	215-219°C or 235 +5/-0°C
Ramp-down rate	6 °C /second max.	10 °C /second max.
Time 25°C to peak temperature	6 minutes max.	

Package Reflow Conditions

pkg. thickness ≥ 2.5mm and all bgas	pkg. thickness < 2.5mm and pkg. volume ≥ 350 mm ³	pkg. thickness < 2.5mm and pkg. volume < 350mm ³
Convection 220 +5/-0 °C		Convection 235 +5/-0 °C
VPR 215-219 °C		VPR 235 +5/-0 °C
IR/Convection 220 +5/-0 °C		IR/Convection 235 +5/-0 °C

Reliability test program

Test item	Method	Description
SOLDERABILITY	MIL-STD-883D-2003	245°C, 5 SEC
HOLT	MIL-STD 883D-1005.7	1000 Hrs Bias @ 125°C
PCT	JESD-22-B, A102	168 Hrs, 100% RH, 121°C
TST	MIL-STD 883D-1011.9	-65°C ~ 150°C, 200 Cycles

Carrier Tape & Reel Dimensions

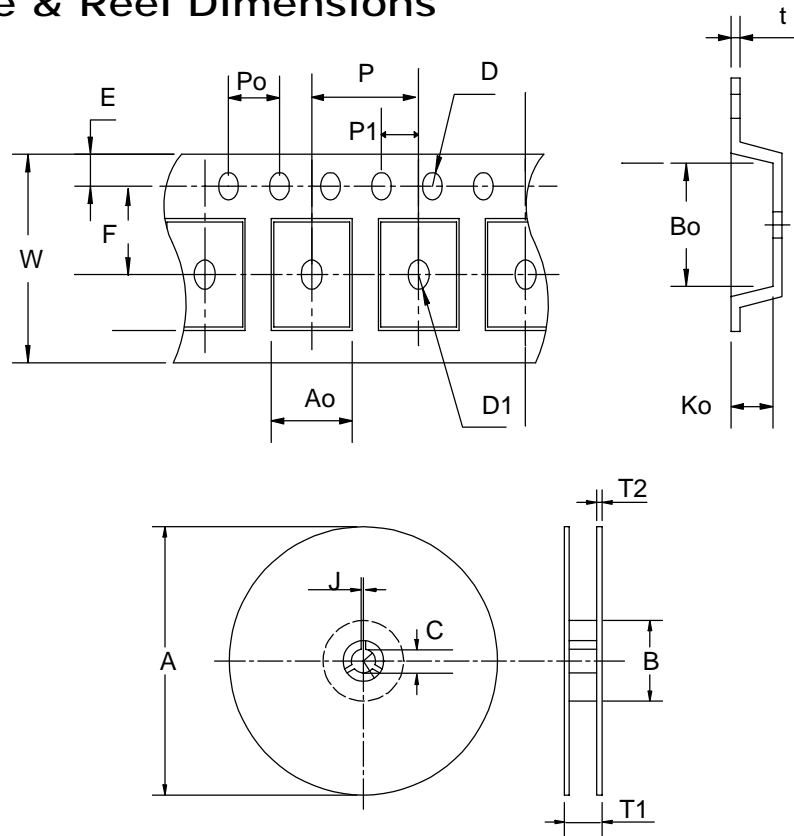

Application	A	B	C	J	T1	T2	W	P	E
SOP-8	330 ± 1	62 +1.5	12.75+ 0.15	2 ± 0.5	12.4 ± 0.2	2 ± 0.2	12 ± 0.3	8 ± 0.1	1.75 ± 0.1
	F	D	D1	Po	P1	Ao	Bo	Ko	t
	5.5 ± 1	1.55 +0.1	1.55 + 0.25	4.0 ± 0.1	2.0 ± 0.1	6.4 ± 0.1	5.2 ± 0.1	2.1 ± 0.1	0.3 ± 0.013
Application	A	B	C	J	T1	T2	W	P	E
TSSOP-8	330 ± 1	62 +1.5	12.75+ 0.15	2 + 0.5	12.4 ± 0.2	2 ± 0.2	12 ± 0.3	8 ± 0.1	1.75 ± 0.1
	F	D	D1	Po	P1	Ao	Bo	Ko	t
	5.5 ± 0.1	1.5 + 0.1	1.5 + 0.1	4.0 ± 0.1	2.0 ± 0.1	7.0 ± 0.1	3.6 ± 0.3	1.6 ± 0.1	0.3 ± 0.013

Cover Tape Dimensions

Application	Carrier Width	Cover Tape Width	Devices Per Reel
SOP- 8	12	9.3	2500
TSSOP- 8	12	9.3	2500

Customer Service

Anpec Electronics Corp.

Head Office :

5F, No. 2 Li-Hsin Road, SBIP,

Hsin-Chu, Taiwan, R.O.C.

Tel : 886-3-5642000

Fax : 886-3-5642050

Taipei Branch :

7F, No. 137, Lane 235, Pac Chiao Rd.,

Hsin Tien City, Taipei Hsien, Taiwan, R. O. C.

Tel : 886-2-89191368

Fax : 886-2-89191369