

# MAGNETIC HEAD FOR CARD USE

## SINGLE TRACK READ WRITE HEAD

### MODEL TG311RW SERIES

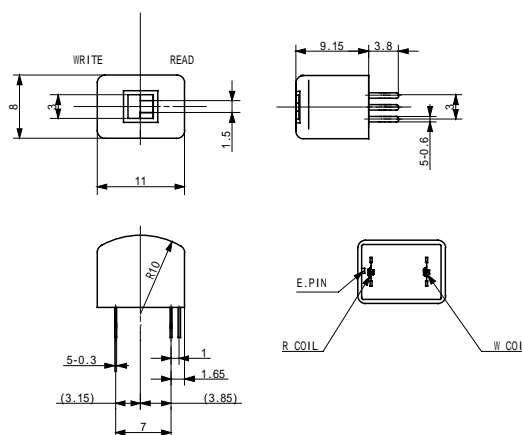

### FEATURE

Compact size and supreme writing performance.

Both High & Low coercivity.

Standard min.500k passes and optional min.1,000k or super-long life of 4,000k passes are available.

Other custom electric specifications are available in this series.

### APPLICATION

ISO standard single track reader/writer.

Bank and card system terminals.

### ELECTRICAL & PHYSICAL SPECIFICATIONS

ITEMS	MEASURING CONDITIONS	TG311RW	Custom Model
D.C. resistance	W	4.5 ± 20%	± %
		R	620 ± 20%
Inductance	1KHz 100 μ A	W	mH ± %
		R	mH ± %
Recording current		330Oe/70/2900Oe/700mAp-p	mAp-p
Read output		40mVp-p ± 30%	mVp-p ± %
Coercivity		330/2900Oe	Oe
Track & Gap width		W:3mm R:1.5mm/30 μ m	W:3mm R:1.5mm/30 μ m
Permalloy cores	Min. passes guaranteed	500k	500k
Sendust cores	As above	1,000k	1,000k
Ceramic treatment	As above	4,000k	4,000k

## TECHRECO CO., LTD.

3-8-8 HAMACHO KAWASAKI-KU KAWASAKI-CITY JAPAN 210-0851

TEL:81-44-355-6161 FAX:81-44-355-6167

For more information & inquiry: [sales@techreco.co.jp](mailto:sales@techreco.co.jp)

<http://www.techreco.co.jp>