

FEATURES

- Fully qualified to Class H or K
- Radiation hardened
- -55° to +125°C operation
- 16 to 40 VDC input
- Fully isolated
- Optocoupler feedback
- Fixed frequency, 550 kHz typical
- Topology – Single Ended Flyback
- Inhibit function
- Indefinite short circuit protection
- 5 watts output power
- Up to 76% efficiency

DC/DC CONVERTERS

28 VOLT INPUT

SMSA SERIES

5 WATT

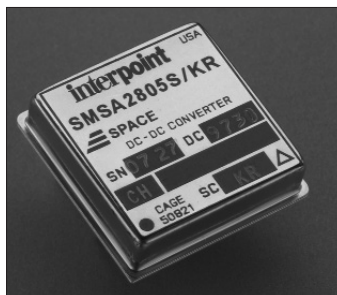

MODELS	
VDC OUTPUT	
SINGLE	DUAL
3.3	±5
5	±12
12	±15
15	

Size (max.): 1.075 x 1.075 x 0.270 inches
(27.31 x 27.31 x 6.86 mm)

See Figures 23 and 24 for dimensions.

Weight: 15 grams maximum.

Screening: Space prototype, Class H, or Class K (MIL-PRF-38534)
Radiation hardness levels O or R

Available configurations: OO, HO, HR, KR

DESCRIPTION

The SMSA Series™ of high frequency DC/DC converters offers a new standard of performance for low power, space qualified DC/DC converters. SMSA converters provide up to 5 watts output power over the full military temperature range of -55°C to +125°C with up to 76% efficiency. Thick-film hybrid techniques provide military/aerospace reliability levels and optimum miniaturization. The hermetically sealed case is only 1.075 by 1.075 inches — with a height of only 0.270 inches. Power density for the SMSA Series converters is 16 watts per cubic inch. The SMSA Series' small size, light weight, and hermetically sealed metal packages make them ideal for use in space, military, aerospace and other high reliability applications.

SCREENING AND REPORTS

SMSA converters offer three screening options – Space prototype Class H, or Class K – and two levels of radiation hardness. See Tables 1 through 3 for more information. Detailed reports on product performance are also available and are listed in Table 4.

CONVERTER DESIGN

The SMSA converters are switching regulators that use a flyback converter design with a constant switching frequency of 550 kHz. They are regulated, isolated units using a pulse width modulated topology and built as high reliability thick-film hybrids. Isolation between input and output circuits is provided with a transformer in the forward power loop and an optical link in the feedback control loop. Excellent input line transient response and audio rejection is achieved by an advanced feed-forward compensation technique. Negative output regulation is maintained by tightly coupled magnetics. Predictable current limit is accomplished by direct monitoring of the output load current, which results in a constant current output above the overload point. Internal input and output filters eliminate the need for external capacitors.

WIDE VOLTAGE RANGE

The SMSA converters are designed to provide full power operation over the full 16 to 40 VDC voltage range. An undervoltage lockout feature keeps the converter shutdown below approximately 13 VDC to ensure smooth initialization.

IMPROVED DYNAMIC RESPONSE

The SMSA feed-forward compensation system provides excellent dynamic response and noise rejection. Audio rejection is typically 50 dB. The minimum to maximum step line transient response is typically less than 1%.

INHIBIT FUNCTION

SMSA converters provide a TTL open collector-compatible inhibit feature that can be used to disable internal switching and inhibit the unit's output. Inhibiting in this manner results in low standby current, and no generation of switching noise.

The converter is inhibited when the TTL compatible low ($\leq 0.8V$) is applied to the inhibit pin. The unit is enabled when the pin, which is internally connected to a pull-up resistor, is left unconnected or is connected to an open collector gate. The open circuit output voltage associated with the inhibit pin is 9 to 11 VDC. In the inhibit mode, a maximum of 4 mA must be sunk from the inhibit pin at 28 VDC input.

SMSA SERIES

5 WATT

DC/DC CONVERTERS

ABSOLUTE MAXIMUM RATINGS

- Input Voltage**
- 16 to 40 V
- Output Power**
- 5 watts
- Lead Soldering Temperature (10 sec per lead)**
- 300°C
- Storage Temperature Range (Case)**
- -65°C to +135°C

INHIBIT

- Inhibit TTL Open Collector**
- Logic low (output disabled)
Logic low voltage ≤ 0.8 V max
Inhibit pin current 4 mA max
 - Referenced to input common
 - Logic high (output enabled)
Open collector

TYPICAL CHARACTERISTICS

- Output Voltage Temperature Coefficient**
- 100 ppm/°C typical
- Input to Output Capacitance**
- 50 pF typical
- Isolation**
- 100 megohm minimum at 500 V
- Audio Rejection**
- 50 dB typical
- Conversion Frequency**
- 550 kHz typical
450 kHz min, 600 kHz max
- Inhibit Pin Voltage (unit enabled)**
- 9 to 11 V

RECOMMENDED OPERATING CONDITIONS

- Input Voltage Range**
- 16 to 40 VDC continuous
 - 50 V for up to 50 msec transient
- Case Operating Temperature (Tc)**
- -55°C to +125°C full power
 - -55°C to +135°C absolute
- Derating Output Power/Current (Tc)**
- Linearly from 100% at 125°C to 0% at 135°C

Electrical Characteristics: 25°C Tc, 28 VDC Vin, 100% load, radiation level O, unless otherwise specified.

SINGLE OUTPUT MODELS		SMSA283R3S			SMSA2805S			SMSA2812S			SMSA2815S			UNITS
PARAMETER	CONDITIONS	MIN	TYP	MAX	MIN	TYP	MAX	MIN	TYP	MAX	MIN	TYP	MAX	
OUTPUT VOLTAGE	Tc = -55°C TO +125°C	3.25	3.30	3.35	4.95	5.00	5.05	11.88	12.00	12.12	14.85	15.00	15.15	VDC
OUTPUT CURRENT	Tc = -55°C TO +125°C VIN = 16 TO 40 VDC	0	—	1200	0	—	1000	0	—	417	0	—	333	mA
OUTPUT POWER	VIN = 16 TO 40 VDC Tc = -55°C TO +125°C	—	—	4	—	—	5	—	—	5	—	—	5	W
OUTPUT RIPPLE VOLTAGE	10 kHz - 2 MHz	—	300	600	—	150	450	—	125	500	—	150	600	mV p-p
LINE REGULATION	VIN = 16 TO 40 VDC Tc = -55°C TO +125°C	—	10	50	—	10	50	—	10	50	—	10	50	mV
LOAD REGULATION	NO LOAD TO FULL Tc = -55°C TO +125°C	—	10	50	—	10	50	—	10	50	—	10	50	mV
INPUT VOLTAGE	Tc = -55°C TO +125°C NO LOAD TO FULL CONTINUOUS	16	28	40	16	28	40	16	28	40	16	28	40	VDC
	TRANSIENT ³ 50 ms	0	—	50	0	—	50	0	—	50	0	—	50	V
INPUT CURRENT	NO LOAD	—	35	60	—	35	60	—	35	60	—	35	60	mA
	FULL LOAD	—	250	—	—	250	—	—	235	—	—	235	—	
	INHIBITED	—	3	5	—	3	5	—	3	5	—	3	5	
INPUT RIPPLE CURRENT	10 kHz - 10 MHz	—	50	200	—	50	200	—	50	200	—	50	200	mA p-p
	Tc = -55°C TO +125°C	—	60	300	—	60	300	—	60	300	—	60	300	
EFFICIENCY		60	—	—	68	74	—	69	74	—	—	—	—	%
LOAD FAULT ^{1, 2}	POWER DISSIPATION	—	1.5	2.4	—	1.5	2.0	—	1.2	1.9	—	1.2	1.8	W
SHORT CIRCUIT	RECOVERY	—	12.5	25	—	12.5	25	—	1	10	—	1	10	ms
STEP LOAD RESPONSE	50% - 100% - 50% TRANSIENT	—	200	500	—	200	500	—	300	750	—	400	1000	mV pk
	RECOVERY ^{2, 3}	—	200	500	—	200	500	—	400	1000	—	400	1000	µs
STEP LINE RESPONSE ^{2, 3}	TRANSIENT 16 TO 40 VIN	—	200	500	—	200	500	—	200	800	—	200	500	mV pk
	40 TO 16 VIN	—	200	500	—	200	500	—	250	600	—	200	500	
	RECOVERY 16 TO 40 VIN	—	400	1000	—	400	1000	—	700	1300	—	500	1300	µs
	40 TO 16 VIN	—	400	1000	—	400	1000	—	700	1300	—	500	1300	
START-UP	DELAY	—	10	75	—	10	75	—	10	75	—	10	75	ms
	OVERSHOOT ³	—	0	200	—	0	200	—	0	500	—	0	500	mV pk

Notes

1. Indefinite short circuit protection not guaranteed above 125°C (case).
2. Recovery time is measured from application of the transient to point at which V_{OUT} is within 1% of V_{OUT} at final value.
3. Guaranteed but not tested.

DC/DC CONVERTERS

SMSA SERIES 5 WATT

Electrical Characteristics: 25°C Tc, 28 VDC Vin, 100% load, radiation level O, unless otherwise specified.

DUAL OUTPUT MODELS		SMSA 2805D			SMSA2812D			SMSA2815D			UNITS	
PARAMETER	CONDITIONS	MIN	TYP	MAX	MIN	TYP	MAX	MIN	TYP	MAX		
OUTPUT VOLTAGE	+V _{OUT}	4.95	5.00	5.05	11.88	12.00	12.12	14.85	15.00	15.15	VDC	
	-V _{OUT}	4.9	5.0	5.1	11.76	12.00	12.24	14.70	15.00	15.30		
OUTPUT CURRENT ¹	V _{IN} = 16 to 40 VDC Tc = -55°C to +125°C	—	±500	800	—	±208	333	—	±167	267	mA	
OUTPUT POWER ¹	V _{IN} = 16 to 40 VDC Tc = -55°C to +125°C	—	—	5	—	—	5	—	—	5	W	
OUTPUT RIPPLE VOLT.	10 kHz - 2 MHz	—	—	300	—	80	300	—	120	300	mV p-p	
LINE REGULATION	V _{in} = 16 to 40 VDC Tc = -55°C to +125°C										mV	
	+V _{OUT}	—	20	100	—	20	100	—	10	50		
	-V _{OUT}	—	40	200	—	40	200	—	40	180		
LOAD REGULATION	NO LOAD TO FULL Tc = -55°C to +125°C										mV	
	+V _{OUT}	—	10	120	—	10	120	—	10	50		
	-V _{OUT}	—	100	400	—	100	400	—	50	200		
CROSS REGULATION ²	+P _O = 30 - 70 %, -P _O = 70 - 30% -P _O = 30 - 70 %, +P _O = 70 - 30%	—	5	8	—	3.7	6	—	3	6	%	
INPUT VOLTAGE	NO LOAD TO FULL CONTINUOUS	16	28	40	16	28	40	16	28	40	VDC	
	TRANSIENT ⁵ 50 msec	—	—	50	—	—	50	—	—	50	V	
INPUT CURRENT	NO LOAD	—	30	50	—	40	63	—	38	60	mA	
	FULL LOAD	—	248	—	—	235	—	—	235	—		
	INHIBITED	—	3	5	—	3	5	—	3	5		
INPUT RIPPLE CURRENT	10 kHz TO 10 MHz	—	50	200	—	50	200	—	50	200	mA p-p	
	Tc = -55°C to +125°C	—	60	300	—	60	300	—	60	300		
EFFICIENCY		65	70	—	67	73	—	68	73	—	%	
LOAD FAULT ^{3, 4}	POWER DISSIPATION SHORT CIRCUIT	—	1.3	2.1	—	1.3	1.7	—	1.3	1.6	W	
	RECOVERY	—	—	50	—	1	30	—	1	50	ms	
STEP LOAD RESPONSE	50% - 100% - 50% BALANCED TRANSIENT	—	±200	±550	—	±200	±550	—	±220	±600	mV	
	RECOVERY ^{4, 5}	—	200	500	—	200	500	—	200	500	µs	
STEP LINE RESP. ^{4, 5}	TRANSIENT	16 TO 40 VDC	—	±200	±500	—	±200	±500	—	±600	±1500	mV pk
		40 TO 16 VDC	—	±200	±500	—	±200	±500	—	±600	±1500	
	RECOVERY	16 TO 40 VDC	—	300	750	—	300	750	—	500	1200	µs
		40 TO 16 VDC	—	800	2000	—	800	2000	—	500	1200	
START-UP	DELAY	—	10	30	—	10	30	—	10	25	ms	
	OVERSHOOT ⁵	—	0	500	—	0	500	—	0	500	mV pk	

Notes

- Up to 4 watts (80% of full power) is available from either output providing the opposite output is carrying 20% of total power.
- Shows regulation effect on the minus output during the defined cross loading conditions, with 80% and 20% referring to the total output power of the converter. See Figures 15 and 16.
- Indefinite short circuit protection not guaranteed above 125°C (case).
- Recovery time is measured from application of the transient to point at which V_{OUT} is within 1% of V_{OUT} at final value.
- Guaranteed but not tested.

**SMSA SERIES
5 WATT**

DC/DC CONVERTERS

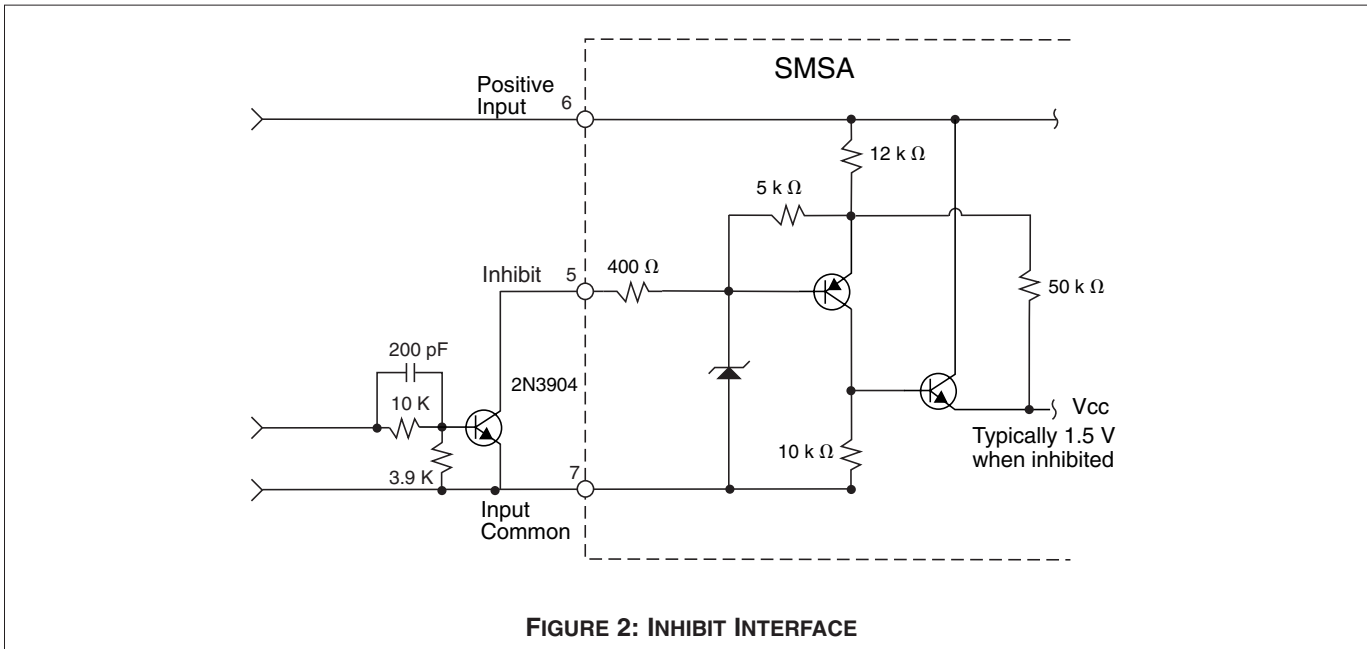
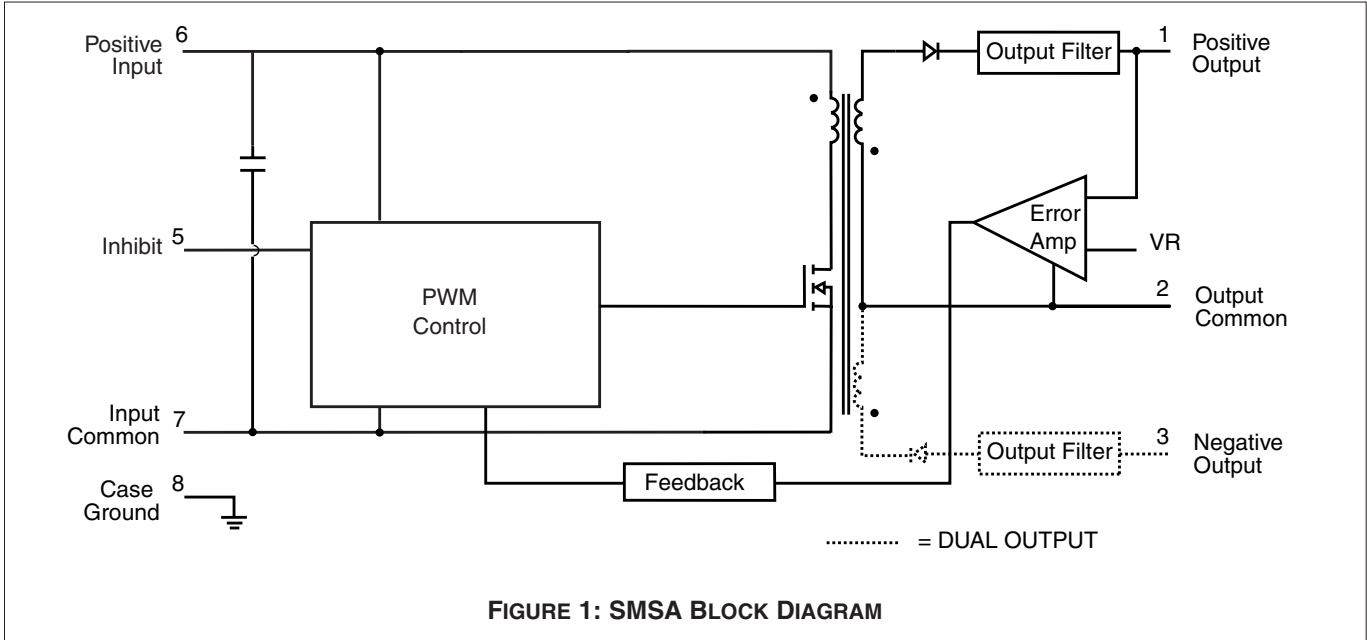

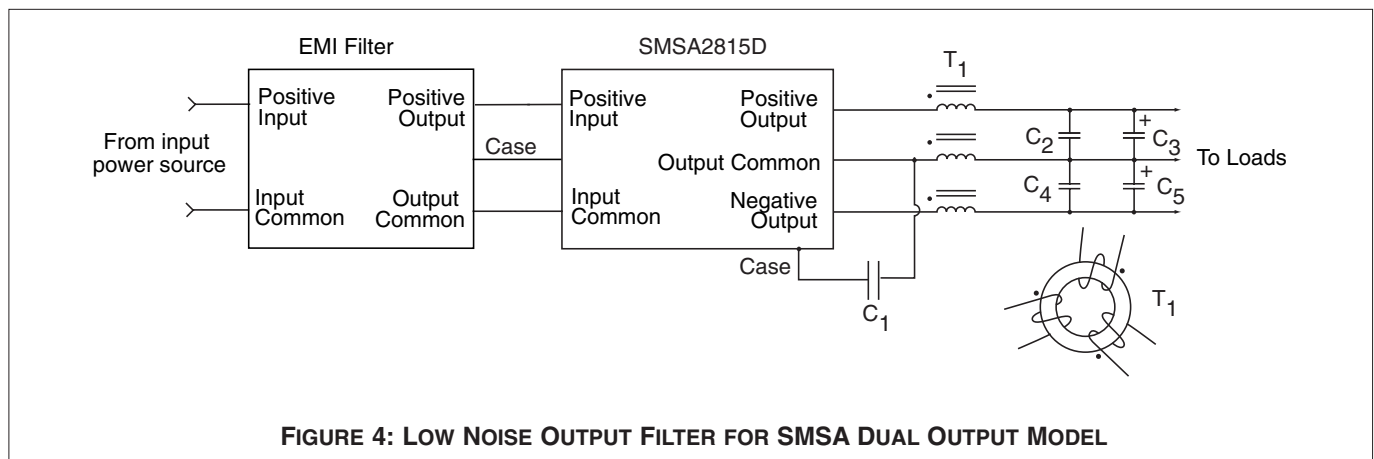
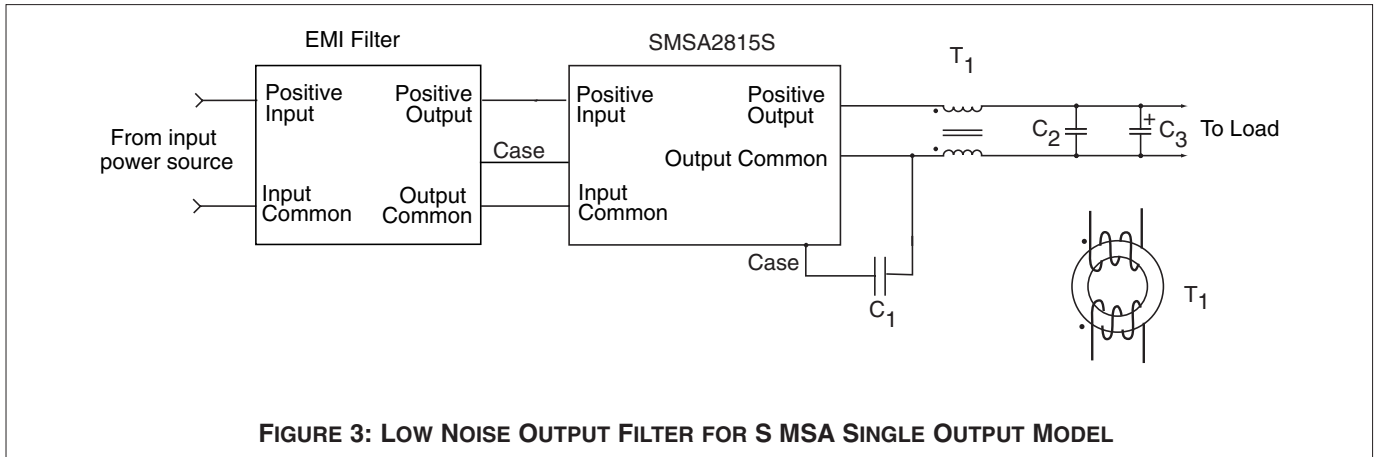

The filter suggestions in Figures 3 and 4 will further reduce the output ripple for systems requiring very low output noise.

C1 = 0.27 μ F ceramic capacitor, 500V

C2 = C4 = 6.8 μ F tantalum capacitor

C3 = C5 = 0.27 μ F ceramic capacitor

Single output: T1 = 15T #28 AWG winding on toroid, $\mu_i = 5000$

Dual output: T2 = 10T #28 AWG winding on toroid, $\mu_i = 5000$

For best results, make interconnections as short as possible.

SMSA SERIES 5 WATT

DC/DC CONVERTERS

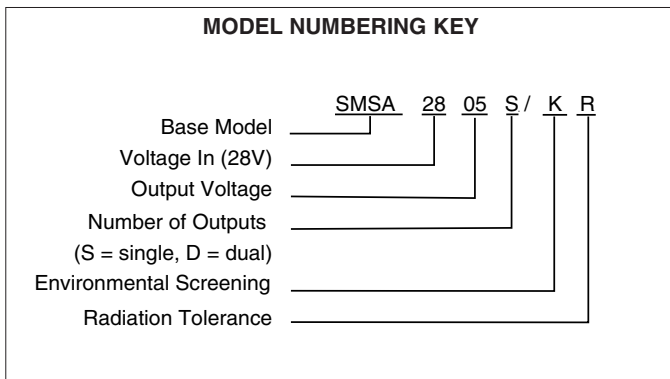
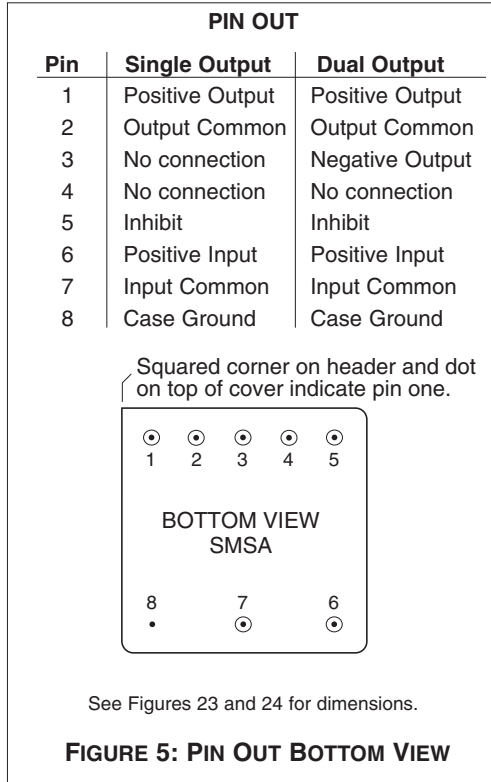

SMD NUMBERS	
STANDARD MICROCIRCUIT DRAWING (SMD)	SMSA SERIES SIMILAR PART
IN PROCESS	SMSA283R3S/HO
5962-9309202HXC	SMSA2805S/HO
5962-9309302HXC	SMSA2812S/HO
5962-9309402HXC	SMSA2815S/HO
5962-9308902HXC	SMSA2812D/HO
5962-9309002HXC	SMSA2815D/HO

The SMD number shown is for Class H screening and no Radiation Hardness Assurance (RHA) level. See the SMD for the numbers for other screening and radiation levels. For exact specifications for an SMD product, refer to the SMD drawing. Call your Interpoint representative for status on the SMSA SMD releases which are "in process." SMDs can be downloaded from:
<http://www.dsccl.dla.mil/programs/smcr>

DC/DC CONVERTERS

SMSA SERIES 5 WATT

Typical Performance Curves: 25°C Tc, 28 VDC Vin, 100% load, unless otherwise specified.

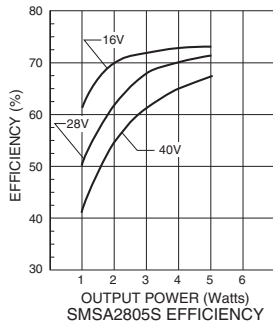

FIGURE 2

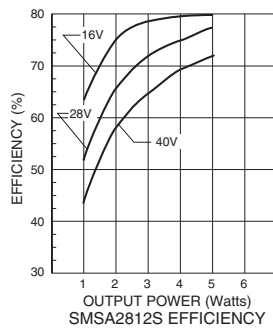

FIGURE 3

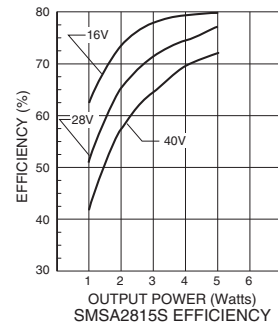

FIGURE 4

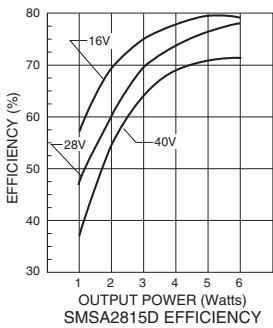

FIGURE 5

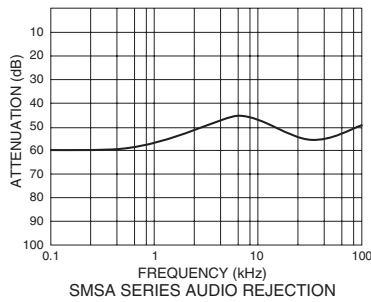
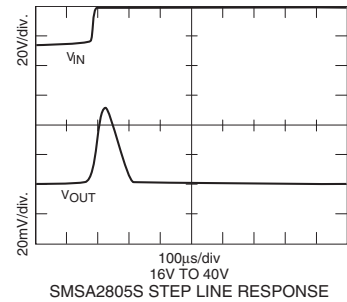
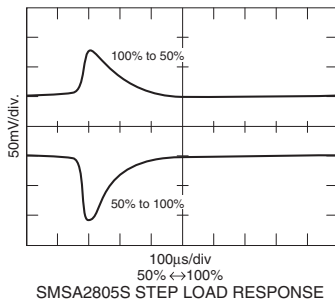

FIGURE 6



SMSA2805S STEP LINE RESPONSE

FIGURE 7



SMSA2805S STEP LOAD RESPONSE

FIGURE 8

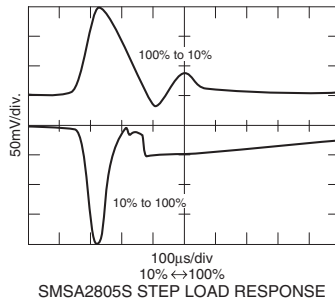

SMSA2805S STEP LOAD RESPONSE

FIGURE 9

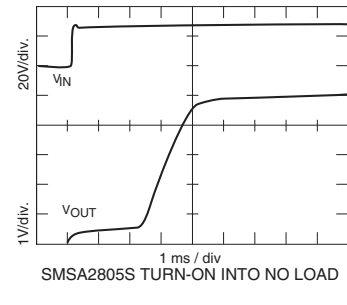

SMSA2805S TURN-ON INTO NO LOAD

FIGURE 10

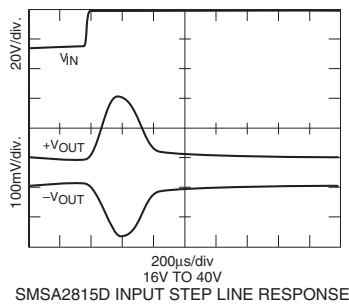

SMSA2815D INPUT STEP LINE RESPONSE

FIGURE 11

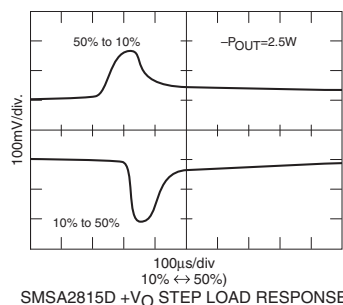

SMSA2815D +V_O STEP LOAD RESPONSE

FIGURE 12

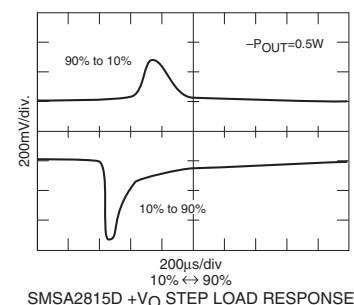

SMSA2815D +V_O STEP LOAD RESPONSE

FIGURE 13

Typical Performance Curves: 25°C Tc, 28 VDC Vin, 100% load, unless otherwise specified.

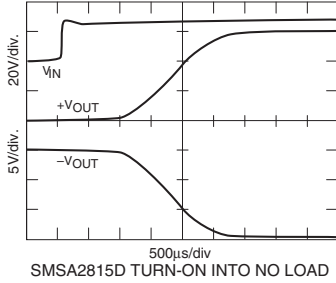

FIGURE 14

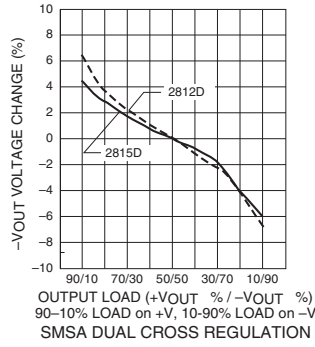

FIGURE 15

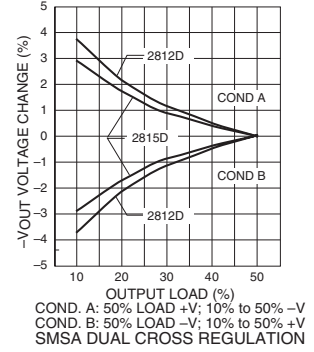

FIGURE 16

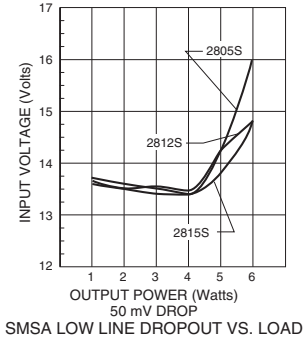

FIGURE 17

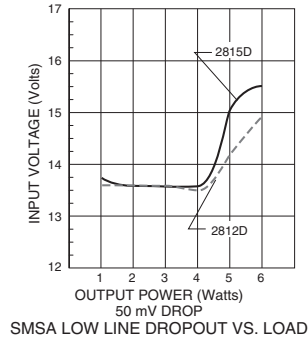
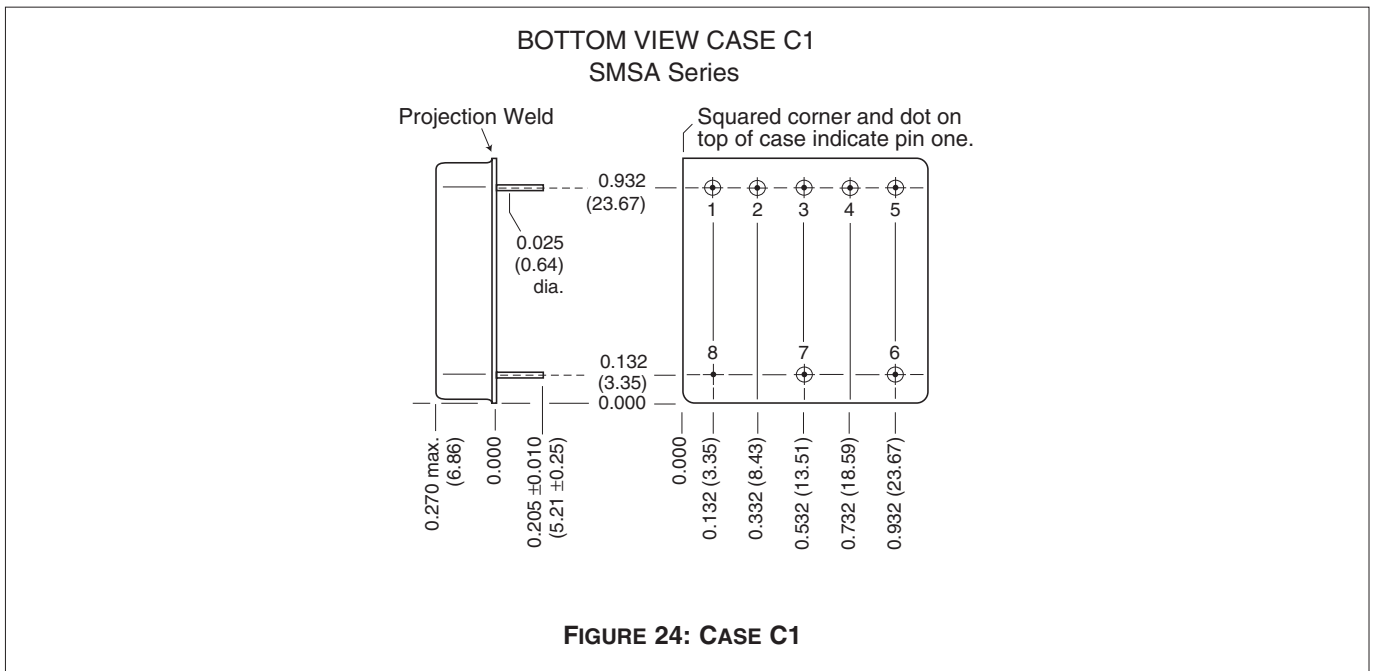
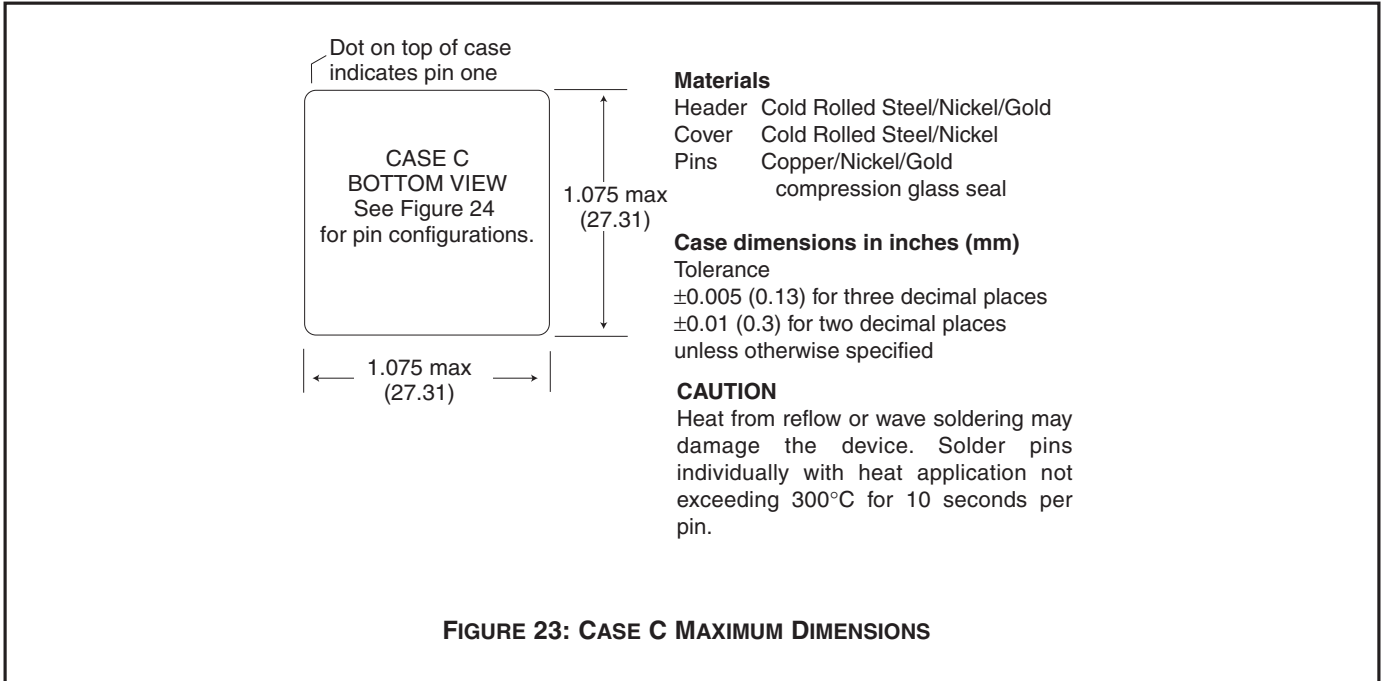

FIGURE 18



Note: Although every effort has been made to render the case drawings at actual size, variations in the printing process may cause some distortion. Please refer to the numerical dimensions for accuracy.

TABLE 1: ELEMENT EVALUATION

ELEMENT EVALUATION TEST PERFORMED (COMPONENT LEVEL)	SPACE PROTOTYPE (O)		CLASS H		CLASS K	
	M/S	P	M/S	P	M/S	P
	Element Electrical	yes	no	yes	yes	yes
Element Visual	no	no	yes	yes	yes	yes
Internal Visual	no	no	yes	no	yes	no
Temperature Cycling	no	no	no	no	yes	yes
Constant Acceleration	no	no	no	no	yes	yes
Interim Electrical	no	no	no	no	yes	no
Burn-in	no	no	no	no	yes	no
Post Burn-in Electrical	no	no	no	no	yes	no
Steady State Life	no	no	no	no	yes	no
Voltage Conditioning /Aging	no	no	no	no	no	yes
Visual Inspection	no	no	no	no	no	yes
Final Electrical	no	no	yes	yes	yes	yes
Wire Bond Evaluation	no	no	yes	yes	yes	yes
SEM	no	no	no	no	yes	no
SLAM™/C-SAM: Input capacitors only (Add'l test, not req. by H or K)	no	no	no	yes	no	yes

Notes

- M/S Active components (Microcircuit and Semiconductor Die)
- P Passive components

Definitions

Element Evaluation: Component testing/screening per MIL-STD-883 as determined by MIL-PRF-38534

SEM: Scanning Electron Microscopy

SLAM™: Scanning Laser Acoustic Microscopy

C-SAM: C - Mode Scanning Acoustic Microscopy

DC/DC CONVERTERS

SMSA SERIES
5 WATT

TABLE 2: PRODUCT ENVIRONMENTAL SCREENING

ENVIRONMENTAL SCREENING TEST PERFORMED (END ITEM LEVEL)	SPACE PROTOTYPE (O)	CLASS H	CLASS K
Non-destruct bond pull Method 2023	no	yes	yes
Pre-cap inspection Method 2017, 2032	yes	yes	yes
Temperature cycle Method 1010, Cond. C	yes	yes	yes
Constant acceleration Method 2001, 3000 g	yes	yes	yes
PIND Test Method 2020, Cond. B	no	yes	yes
Radiography Method 2012	no	no	yes
Pre burn-in test	yes	yes	yes
Burn-in, Method 1015, 125°C			
96 hours	yes	no	no
160 hours	no	yes	no
2 x 160 hour (includes mid BI test)	no	no	yes
Final electrical test MIL-PRF-38534, Group A	yes	yes	yes
Hermeticity test			
Fine Leak, Method 1014, Cond. A	yes	yes	yes
Gross Leak, Method 1014, Cond. C	yes	yes	yes
Final visual inspection Method 2009	yes	yes	yes

Test methods are referenced to MIL-STD-883 as determined by MIL-PRF-38534.

**SMSA SERIES
5 WATT**

DC/DC CONVERTERS

TABLE 3: RADIATION HARDNESS LEVELS

PRODUCT LEVEL AVAILABILITY	ENVIRONMENTAL SCREENING LEVELS		
	SPACE PROTOTYPE (O)	CLASS H	CLASS K
RADIATION HARDNESS LEVELS			
O: Standard, no radiation guarantee For system evaluation, electrically and mechanically comparable to H and K level.	OO	HO	Not available
R: Radiation hardened – Tested lots Up to 100 k Rads (Si) total dose SEU guarantee up to 40 MeV	Not available	HR	KR

R is referenced to MIL-PRF-38534, appendix G, Radiation Hardness Assurance (RHA) levels.

TABLE 4: REPORTS: AVAILABLE FOR CUSTOMER REVIEW AT INTERPOINT
<ul style="list-style-type: none"> 1. Radiation Susceptibility Analysis 2. Electrical/Thermal Stress Analysis and Derating Report 3. MTBF Report 4. FMEA Report <p>HO option: Reports 2, 3, and 4 are included with purchase. OO option: Select reports available as separate purchases.</p>

Contact Information:

www.interpoint.com

Interpoint Headquarters USA
 Phone: 1-800-822-8782
 +425-882-3100
 Email: power@intp.com

Interpoint UK
 Phone: +44-1252-872266
 Email: poweruk@intp.com

Interpoint France
 Phone: +33-134285455
 Email: powerfr@intp.com