

Typical Applications

The HMC499LC4 is ideal for use as a driver or power amplifier for:

- Point-to-Point Radios
- Point-to-Multi-Point Radios & VSAT
- Test Equipment & Sensors
- Military End-Use

Features

- +34 dBm Output IP3
- Saturated Power: +24 dBm @ 16% PAE
- 16 dB Gain
- +5.0 V @ 200 mA Supply
- 50 Ohm Matched Input/Output
- RoHS Compliant 4x4 mm SMT Package

Functional Diagram

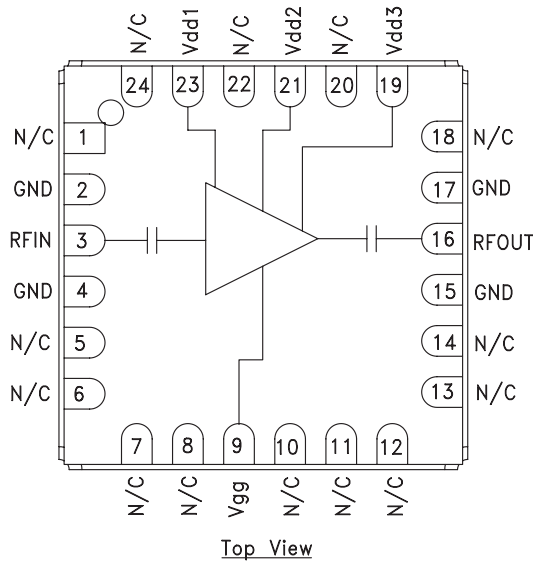

General Description

The HMC499LC4 is a high dynamic range GaAs PHEMT MMIC Medium Power Amplifier housed in a leadless "Pb free" RoHS Compliant SMT package. Operating from 21 to 32 GHz, the amplifier provides 16 dB of gain, +24 dBm of saturated power and 16% PAE from a +5.0 V supply voltage. The RF I/Os are DC blocked and matched to 50 Ohms for ease of use. The HMC499LC4 eliminates the need for wire bonding, allowing use of surface mount manufacturing techniques.

Electrical Specifications, $T_A = +25^\circ C$, $V_{dd1, 2, 3} = 5V$, $I_{dd} = 200 mA^*$

Parameter	Min.	Typ.	Max.	Min.	Typ.	Max.	Min.	Typ.	Max.	Units
Frequency Range	21 - 24			24 - 28			28 - 32			GHz
Gain	14	17		13	16		9	13		dB
Gain Variation Over Temperature		0.02	0.03		0.02	0.03		0.02	0.03	dB/ °C
Input Return Loss		10			8			8		dB
Output Return Loss		11			12			8		dB
Output Power for 1 dB Compression (P1dB)	20	23		20	23		20	23		dBm
Saturated Output Power (Psat)		23.5			23.5			24		dBm
Output Third Order Intercept (IP3)		31			34			33.5		dBm
Noise Figure		6			5			5		dB
Supply Current (Idd)(Vdd = +5V, Vgg = -0.8V Typ.)		200			200			200		mA

* Adjust Vgg between -2 to 0V to achieve Idd = 200 mA typical.



**SMT PHEMT MEDIUM
POWER AMPLIFIER, 21 - 32 GHz**

Broadband Gain & Return Loss

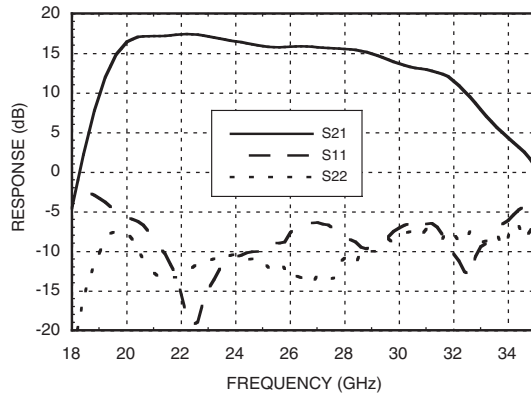

Gain vs. Temperature

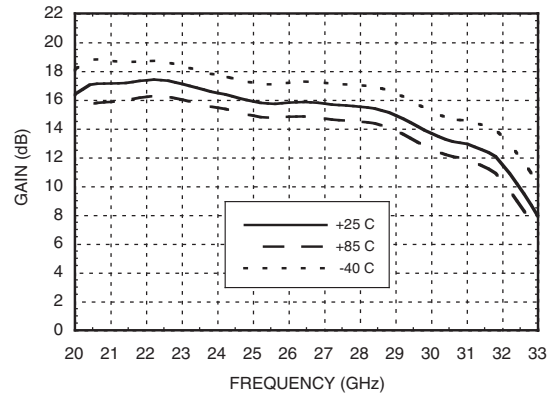

Input Return Loss vs. Temperature

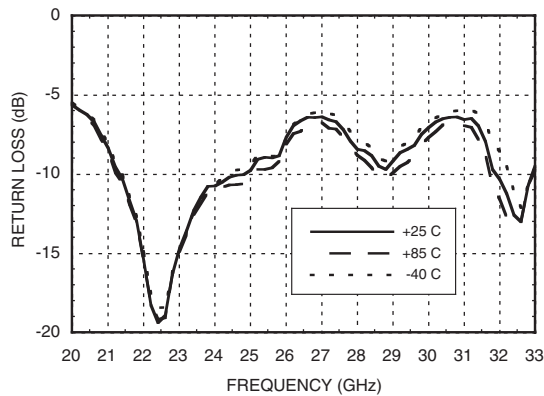

Output Return Loss vs. Temperature

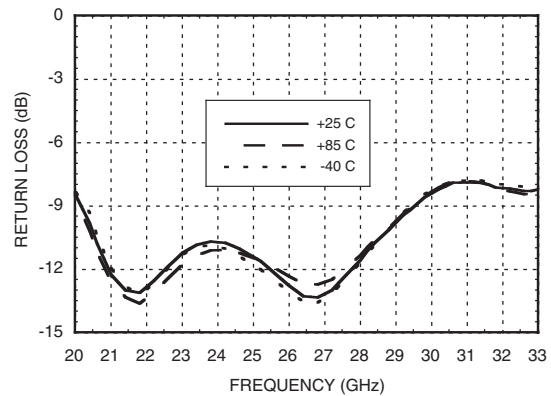

P1dB vs. Temperature

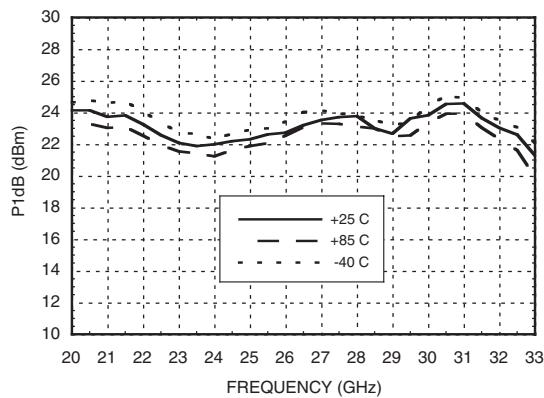

Psat vs. Temperature

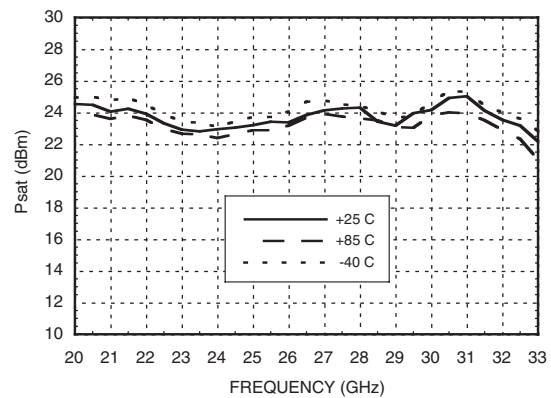

SMT PHEMT MEDIUM POWER AMPLIFIER, 21 - 32 GHz

Output IP3 vs. Temperature

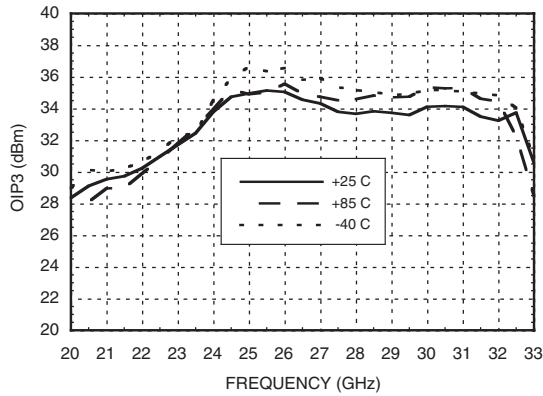

Noise Figure vs. Temperature

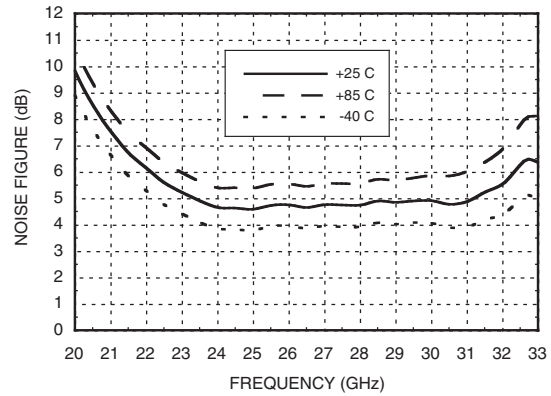

Gain, Power & OIP3 vs. Supply Voltage @ 22 GHz

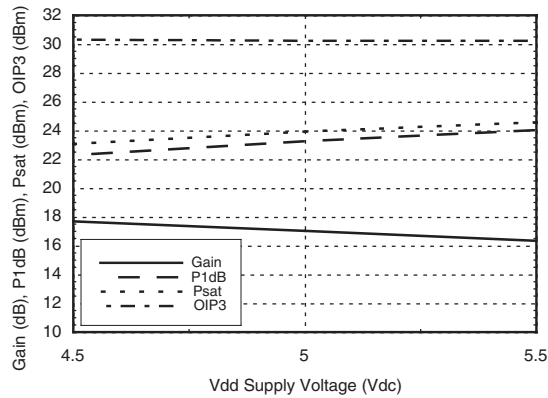

Reverse Isolation vs. Temperature

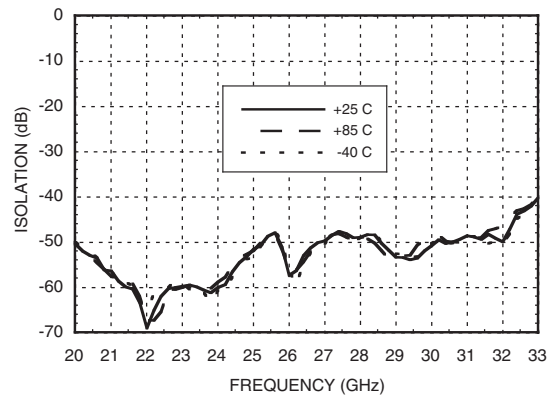

Power Compression @ 22 GHz

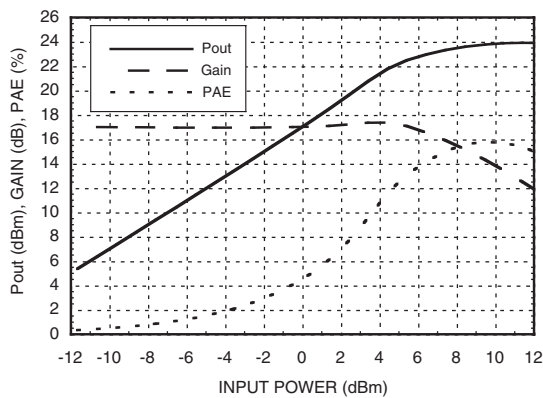

Power Compression @ 30 GHz

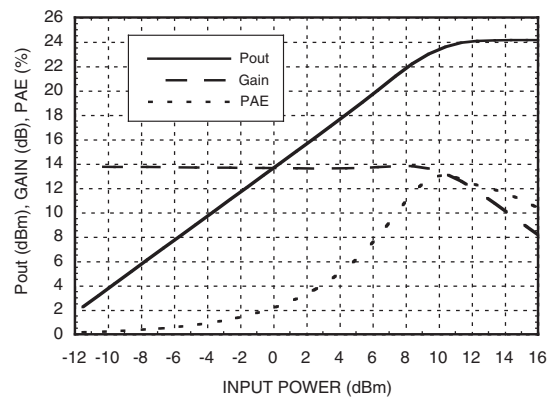

SMT PHEMT MEDIUM POWER AMPLIFIER, 21 - 32 GHz

Absolute Maximum Ratings

Drain Bias Voltage (Vdd1, Vdd2, Vdd3)	+5.5 Vdc
Gate Bias Voltage (Vgg)	-4.0 to 0 Vdc
RF Input Power (RFIn)(Vdd = +5.0 Vdc)	+20 dBm
Channel Temperature	175 °C
Continuous Pdiss (T= 85 °C) (derate 25 mW/°C above 85 °C)	2.25 W
Thermal Resistance (channel to ground paddle)	40 °C/W
Storage Temperature	-65 to +150 °C
Operating Temperature	-40 to +85 °C

Typical Supply Current vs. Vdd

Vdd (Vdc)	Idd (mA)
+4.5	193
+5.0	200
+5.5	207

Note: Amplifier will operate over full voltage ranges shown above. Vgg adjusted to achieve Idd= 200 mA at +5.0V.



ELECTROSTATIC SENSITIVE DEVICE
OBSERVE HANDLING PRECAUTIONS

Outline Drawing

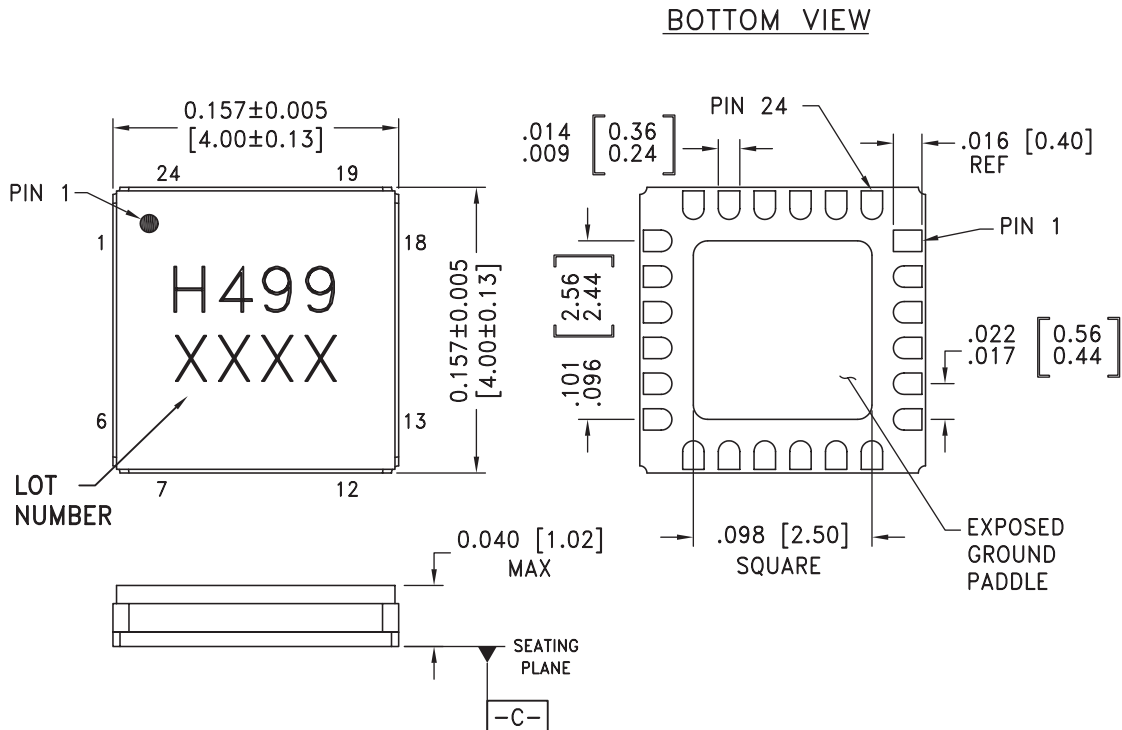

NOTES:

1. PACKAGE BODY MATERIAL: ALUMINA.
2. LEAD AND GROUND PADDLE PLATING: GOLD FLASH OVER NICKEL.
3. DIMENSIONS ARE IN INCHES (MILLIMETERS).
4. LEAD SPACING TOLERANCE IS NON-CUMULATIVE.
5. PACKAGE WARP SHALL NOT EXCEED 0.05MM DATUM -C-
6. ALL GROUND LEADS AND GROUND PADDLE MUST BE SOLDERED TO PCB RF GROUND.

Pin Descriptions

Pin Number	Function	Description	Interface Schematic
1, 5-8, 10-14, 18, 20, 22, 24	N/C	No connection required. These pins may be connected to RF/DC ground without affecting performance.	
2, 4, 15, 17	GND	Package bottom has an exposed metal paddle that must also be connected to RF/DC ground.	
3	RFIN	This pin is AC coupled and matched to 50 Ohms from 21 - 32 GHz.	
9	Vgg	Gate control for amplifier. Adjust to achieve Id of 200 mA. Please follow "MMIC Amplifier Biasing Procedure" Application Note. External bypass capacitors of 100 pF, 1000 pF and 2.2 μF are required.	
16	RFOUT	This pad is AC coupled and matched to 50 Ohms from 21 - 32 GHz.	
23, 21, 19	Vdd1, Vdd2, Vdd3	Power Supply Voltage for the amplifier. External bypass capacitors of 100 pF, 1000pF, and 2.2 μF are required.	

Application Circuit

Component	Value
C1	100 pF
C2	1,000 pF
C3	2.2 μF

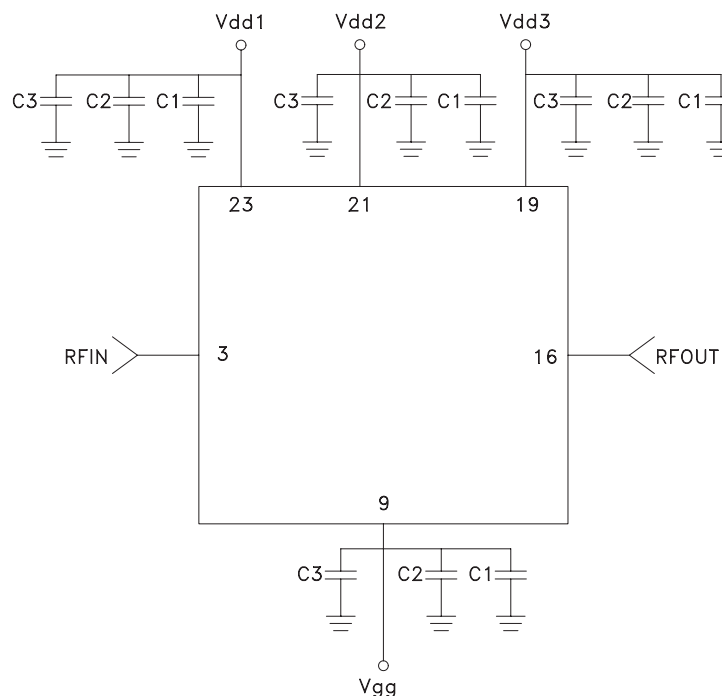

Evaluation PCB

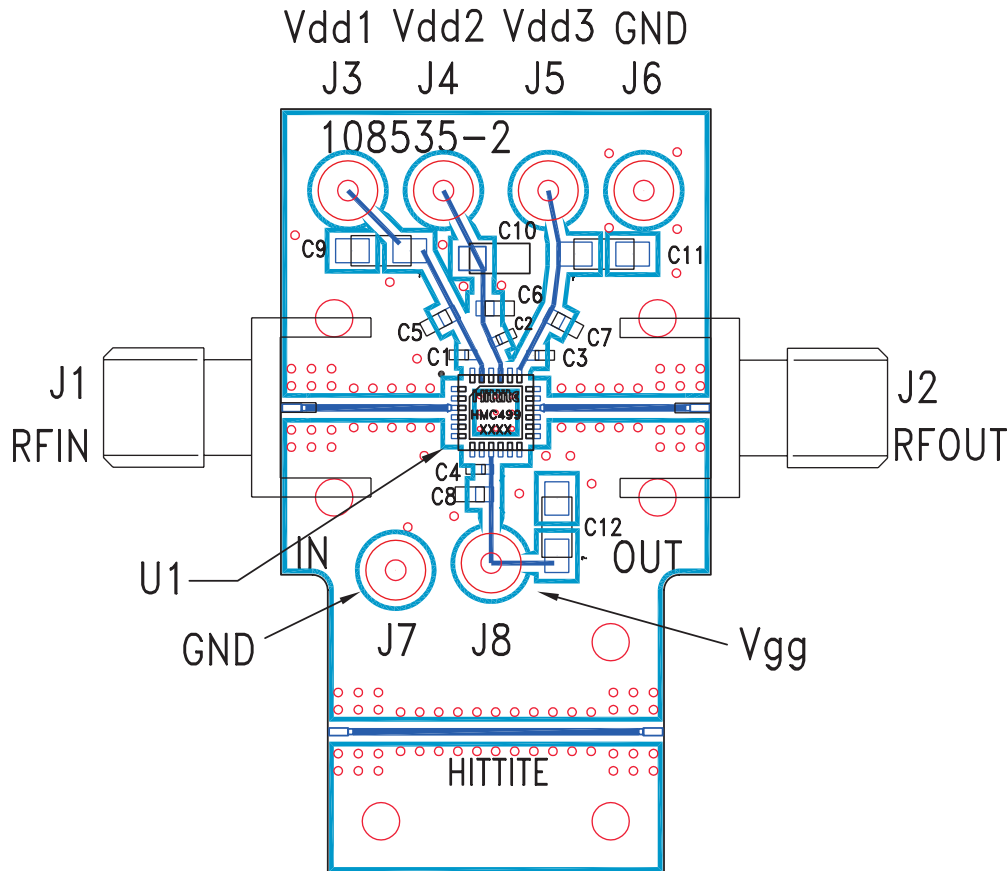

List of Material for Evaluation PCB 108537 ^[1]

Item	Description
J1, J2	2.92 mm PC mount K-connector
J3 - J8	DC Pin
C1 - C4	100 pF capacitor, 0402 pkg.
C5 - C8	1,000 pF Capacitor, 0603 pkg.
C9 - C12	2.2µF Capacitor, Tantalum
U1	HMC498LC4 Amplifier
PCB ^[2]	108535 Evaluation PCB

[1] Reference this number when ordering complete evaluation PCB

[2] Circuit Board Material: Rogers 4350.

The circuit board used in this application should use RF circuit design techniques. Signal lines should have 50 ohm impedance while the package ground leads and exposed paddle should be connected directly to the ground plane similar to that shown. A sufficient number of VIA holes should be used to connect the top and bottom ground planes. The evaluation board should be mounted to an appropriate heat sink. The evaluation circuit board shown is available from Hittite upon request.