

MEGA BRIGHT LED

BTL-32BLC-XX-X

Product Features

- Ultra Bright Blue Color
- High Light Output
- 3mm Diameter Circular Package
- Water Clear Lens
- Highly Reliable
- IC Compatible
- Leads without Stand Off

Package Dimension

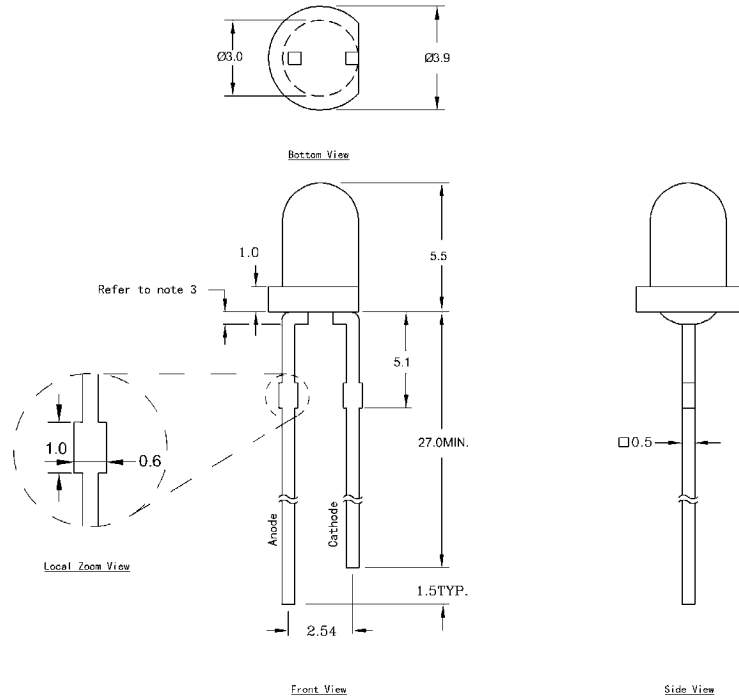

Applications

- Automotive
- Front Panel Indicator
- Special Lighting
- General Purpose LEDs

WARNING
This range of LEDs is produced with die having a high radiant flux. Care must be taken when viewing the product at close range as the light may be intense enough to cause damage to the human eye.

Note: Industry standard procedures regarding static must be observed when handling this product.

Tolerance: $\pm \frac{\text{inch}}{\text{mm}}$ Unit: $\pm \frac{0.01}{0.25}$

Optical and Electrical Characteristics at $T_a=25^\circ\text{C}$

Parameter	Symbol	Minimum	Typical	Maximum	Units	Conditions
Luminous Intensity	I_v	—	1200	—	mcd	$I_F = 20\text{mA}$ (Note 1)
Viewing Angle	$2\theta_{1/2}$	—	30	—	deg	$I_F = 20\text{mA}$
Dominant Wavelength	λ_D	460	465	475	nm	$I_F = 20\text{mA}$ (Note 2)
DC Forward Voltage	V_F	2.8	3.5	4.0	V	$I_F = 20\text{mA}$
DC Reverse Current	I_R	0	—	10	μA	$V_R=5\text{V}$

Notes:

1. Light intensity measures the light sensing response standard using chromatic meter. Refer to the CIE eye-response curve set by International Lighting committee. Tolerance of minimum and maximum intensity = $\pm 15\%$
2. Wavelength range can be selected from the bin selection table. Tolerance of minimum and maximum = $\pm 2\text{nm}$
3. These products are sensitive to static electricity and care must be fully taken when handling products



MEGA BRIGHT LED

BTL-32BLC-XX-X

Absolute Maximum Ratings at $T_a=25^\circ\text{C}$

Symbol	Parameter	Max.	Unit
P_D	Power Rating	100	mW
V_R	Reverse Voltage ($I_R=10\mu\text{A}$)	5	V
I_F	Continuous Forward Current	30	mA
I_{FP}	Peak Forward Current (0.1 duty cycle @ 1kHz)	100	mA
T_{opr}	Operating Temperature Range	-35 ~ + 80	$^\circ\text{C}$
T_{stg}	Storage Temperature Range	-40 ~ + 100	$^\circ\text{C}$
Lead Soldering Temperature [1.6mm (0.063inch) from body]		260 $^\circ\text{C}$ - max 5 seconds	

Wavelength and Brightness Selection

BTL-32BLC-XX-X

Wavelength Bin Selection

Bin	Blue (nm)
B5	460~465
B6	465~470
B7	470~475
XX	460~475

Brightness Bin Selection

Bin	Range(mcd)
L	520~675
M	675~880
N	880~1140
O	1140~1485
P	1485~1930

Packaging Options

Standard: 1000 pc bulk pack

Optional: Tape and Reel (Please specify when order)

MEGA BRIGHT LED

BTL-32BLC-XX-X

Typical Electro-Optical Characteristics Curves at $T_a=25^\circ\text{C}$

