

**High Dynamic Range LNA
800 - 1000 MHz**

**MAALSS0040
V1**

Features

- Ideal for Base Station Applications
- High Gain: 17 dB @ 900 MHz
- Low Noise Figure: ≤ 1.0 dB @ 900 MHz
- Lead-Free SOT-26 Package
- 100% Matte Tin Plating over Copper
- Halogen-Free "Green" Mold Compound
- 260°C Reflow Compatible
- RoHS* Compliant Version of AM50-0011

Description

M/A-COM's MAALSS0040 is a high dynamic range, GaAs MMIC, low noise amplifier in a lead-free SOT-26 package. It employs external matching to obtain optimum noise figure and intercept performance. The MAALSS0040 may be operated with supply voltages of +5 V.

The MAALSS0040 is ideally suited for use where low noise figure, high gain, and high dynamic range are required. Typical applications included receiver front ends in AMPS, GSM and ETACS base stations. It may also be used as an IF amplifier in certain other communication systems.

The MAALSS0040 is fabricated using a low-cost 0.5-micron gate E-D GaAs process. This process features full passivation for increased reliability.

Ordering Information

Part Number	Package
MAALSS0040	Bulk Packaging
MAALSS0040TR-3000	3000 piece reel
MAALSS0040SMB	Sample Test Board

Note: Reference Application Note M513 for reel size information.

Functional Block Diagram

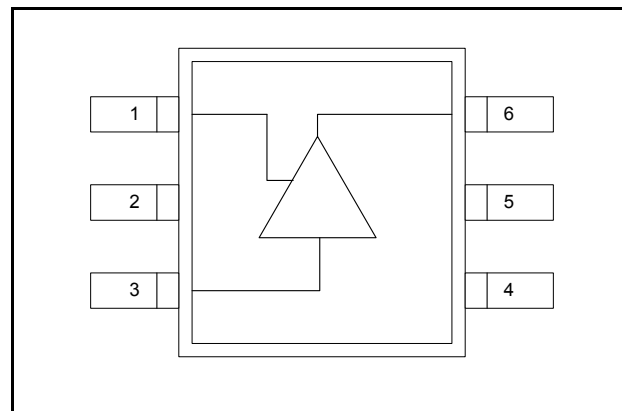

Pin Configuration

Pin No.	Function	Pin No.	Function
1	V _B	4	Ground
2	Ground	5	Ground
3	RF Input	6	RF Output/V _{DD}

Absolute Maximum Ratings ^{1,2}

Parameter	Absolute Maximum
Supply Voltage	6 V
RF input Power	8 dBm
Operating Temperature	-40°C to +85°C
Storage Temperature	-65°C to +150°C

1. Exceeding any one or combination of these limits may cause permanent damage to this device.
2. M/A-COM does not recommend sustained operation near these survivability limits.

* Restrictions on Hazardous Substances, European Union Directive 2002/95/EC.

**High Dynamic Range LNA
800 - 1000 MHz**

**MAALSS0040
V1**

Electrical Specifications: $T_A = 25^\circ\text{C}$, $Z_0 = 50 \Omega$, $V_{DD} = 5 \text{ V}$

Parameter	Test Conditions	Units	Min	Typ	Max
Gain	900 MHz, $P_{IN} = -20 \text{ dBm}$	dB	15.8	16.8	17.8
Noise Figure	900 MHz, $P_{IN} = -20 \text{ dBm}$	dB	—	0.95	1.3
Output P1dB	900 MHz	dBm	—	14	—
Input IP3	Two tone, -20 dBm / tone, 300 KHz spacing, 900 MHz	dBm	—	13.5	—
Input VSWR	900 MHz, $P_{IN} = -20 \text{ dBm}$	—	—	1.5:1	—
Output VSWR	900 MHz, $P_{IN} = -20 \text{ dBm}$	—	—	1.7:1	—
Current	—	mA	—	40	60

Application Schematic

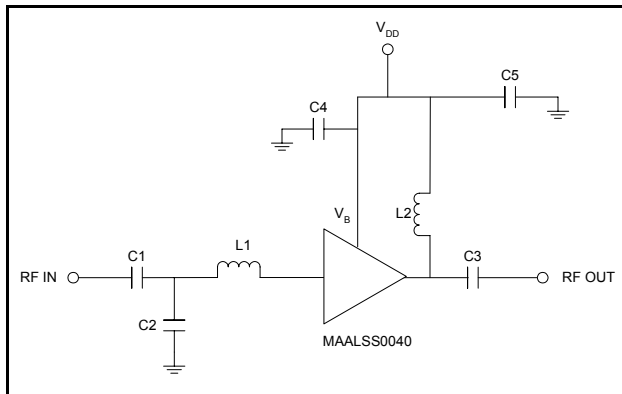

Component List

Part	Value	Case Size	Manufacturer
L1	6.8 nH	0402	Coilcraft
L2	68 nH	0402	Coilcraft
C1	1000 pF	0402	Murata
C2	3.9 pF	0402	Murata
C3	100 pF	0402	Murata
C4, C5	0.1 μF	0402	Murata

Lead-Free SOT-26 Plastic Package†

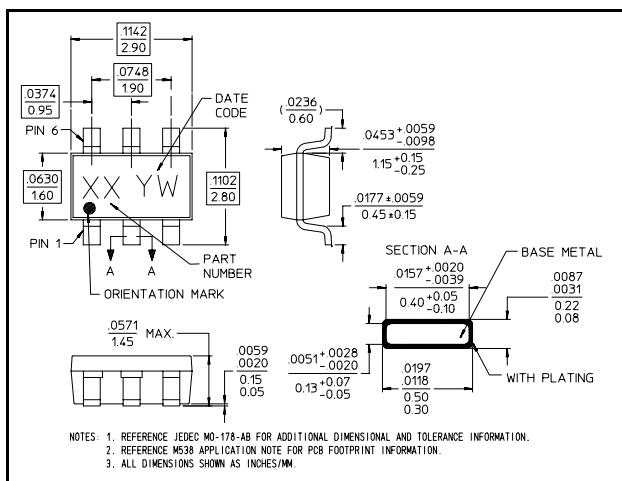

† Reference Application Note M538 for lead-free solder reflow recommendations.

Handling Procedures

Please observe the following precautions to avoid damage:

Static Sensitivity

Gallium Arsenide Integrated Circuits are sensitive to electrostatic discharge (ESD) and can be damaged by static electricity. Proper ESD control techniques should be used when handling these devices.

Typical Performance Curves

Gain

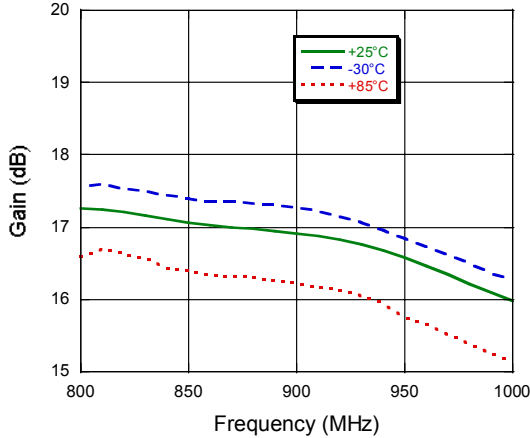

Noise Figure

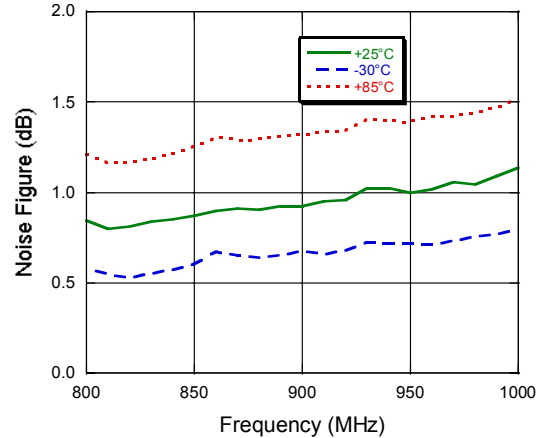

Input VSWR

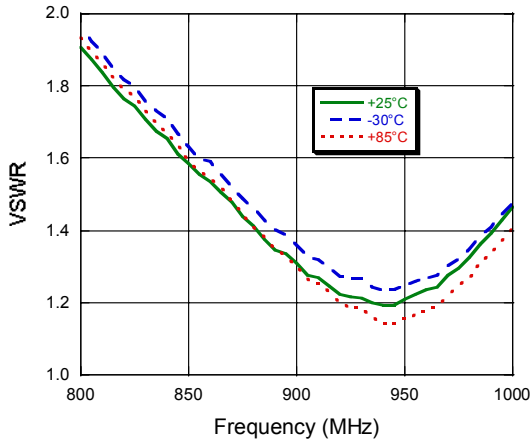

Output VSWR

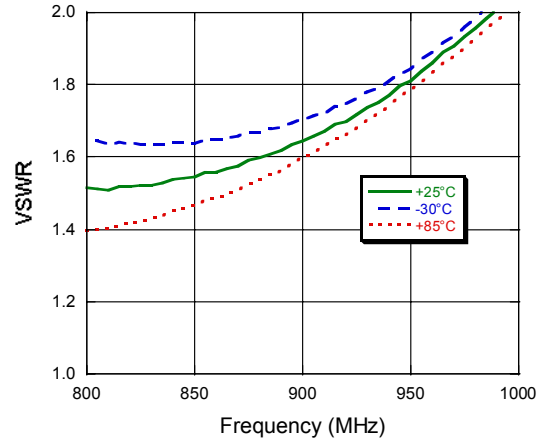

P1dB

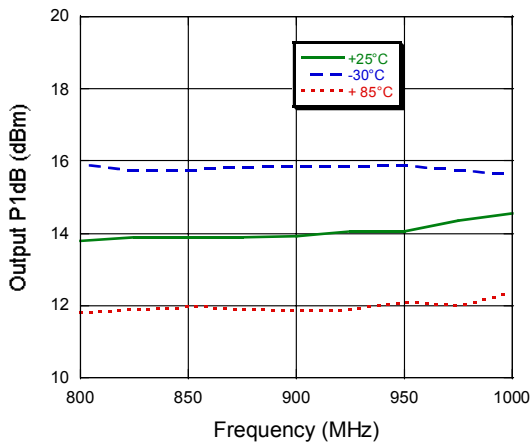

Input IP3

