



Details are subject to change without notice

6+1-CHANNEL BUFFER FOR TFT LCD

FEATURES

- 6+1 Channel:
6 Channels with an Output Current of $\pm 30\text{mA}$ (MAX); 1 V_{com} with an Output Current of $\pm 100\text{mA}$ (MAX)
- Unity Gain Buffer Capable of Driving Large Capacitive Loads
- Input Range Matched to LCD Reference Requirements
- V_{DD} Specified for 6.5V to 16.0V
- TSSOP Power PAD-20 & SOP20 Package Available

GENERAL DESCRIPTION

The AAT7204 consists of 6+1 channel buffers target toward the needs of thin film transistor liquid crystal display (TFT LCD). This device consists of a V_{com} buffer circuits, two rail-to-rail buffer amplifier circuits and 4 buffer amplifier circuits. Each buffer is capable of driving heavy capacitive loads and offering fast current loading (V_{com} : 100mA, the others: 30mA).

The AAT7204 comes in alternative TSSOP Power PAD-20 or SOP20 package. Diversity makes this device an ideal part for LCD monitors and LCD TVs.

PIN CONFIGURATION

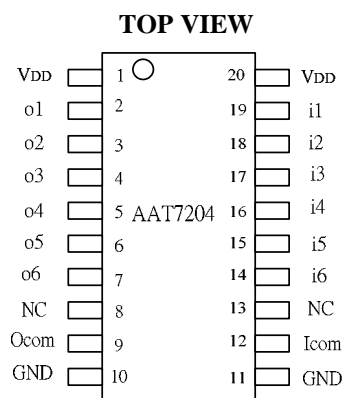

TSSOP Power PAD-20 & SOP20 Package

**PIN DESCRIPTION**

PIN NO.	NAME	I/O	DESCRIPTION
1	V _{DD}	I	Power Supply
2	o1	O	Buffer Channel 1 Output
3	o2	O	Buffer Channel 2 Output
4	o3	O	Buffer Channel 3 Output
5	o4	O	Buffer Channel 4 Output
6	o5	O	Buffer Channel 5 Output
7	o6	O	Buffer Channel 6 Output
8	NC	-	-
9	O _{com}	O	Com Buffer Output
10	GND	I	Ground
11	GND	I	Ground
12	I _{com}	I	Com Buffer Input
13	NC	-	-
14	i6	I	Buffer Channel 6 Input
15	i5	I	Buffer Channel 5 Input
16	i4	I	Buffer Channel 4 Input
17	i3	I	Buffer Channel 3 Input
18	i2	I	Buffer Channel 2 Input
19	i1	I	Buffer Channel 1 Input
20	V _{DD}	I	Power Supply

**ABSOLUTE MAXIMUM RATINGS**

CHARACTERISTICS	SYMBOL	VALUE	UNIT
Supply Voltage	V_{DD}	+18	V
Input Voltage	V_I	-0.5 to $V_{DD} + 0.5$	V
Output Voltage	V_O	-0.5 to $V_{DD} + 0.5$	V
Output Loading Current for Gamma , Rail-to-Rail Buffer	I_L	± 30	mA
Output Loading Current for Com Buffer		± 100	mA
Maximum Junction Temperature	T_J	+125	°C
Operating Temperature	T_C	- 20 to +85	°C
Storage Temperature	$T_{storage}$	- 45 to +125	°C
Lead Temperature (Soldering for 10 Seconds)	---	260	°C

Note 1: Values beyond absolute maximum ratings may cause permanent damage to the device.

**ELECTRICAL CHARACTERISTICS ($V_{DD}=10V$, $T_C=25^{\circ}C$ UNLESS OTHERWISE SPECIFIED)****POWER SUPPLY PERFORMANCE**

PARAMETER		TEST CONDITIONS	MIN	TYP	MAX	UNITS
Power Supply Rejection Ratio	PSRR	V_{DD} varies from 6.5V to 16.0V	-	80	-	dB
Supply Current	I_S		-	6.7	-	mA

INPUT CHARACTERISTICS

PARAMETER		TEST CONDITIONS	MIN	TYP	MAX	UNITS
Input Offset Voltage	V_{OS}	$V_I = V_{DD}/2$, $V_O = V_{DD}/2$	-	2	12	mV
Input Bias Current	I_B	$V_I = V_{DD}/2$, $V_O = V_{DD}/2$	-	2	50	nA



OUTPUT CHARACTERISTICS

PARAMETER		TEST CONDITIONS	MIN	TYP	MAX	UNITS
Output Swing Low	V _{OL}	I _L = 5mA (Buffer 1, 6) V _I = 0V	-	0.08	0.15	V
		I _L = 10mA (Buffer 2, 3, 4, 5) V _I = 1V	-	1.02	1.05	V
Output Swing High	V _{OH}	I _L = -5 mA (Buffer 1, 6) V _I = 10V	9.85	9.92	-	V
		I _L = -10 mA (Buffer 2, 3, 4, 5) V _I = 9V	8.95	8.98	-	V
Output Swing (Buffer 2, 3, 4, 5)	V _{OL}	I _L = 10mA, V _I = 5V	-	5.02	5.04	V
	V _{OH}	I _L = -10 mA, V _I = 5V	4.96	4.98	-	V
Output Swing (COM)	V _{OL}	I _L = 50mA, V _I = 5V	-	5.03	5.05	V
	V _{OH}	I _L = -50 mA, V _I = 5V	4.95	4.97	-	V
Short Circuit Current	I _{SC}	(Buffer 2~5)	-	± 70	-	mA
		(Com Buffer, Buffer1, 6)	-	± 180	-	mA

AC Characteristics

Parameter		Test Conditions	Min	Typ	Max	Units
Slew Rate (Note 2)	SR	V _I = 2V to 8V, 20% to 80%	-	1	-	V/μs
Settling Time	t _s	V _I = 4.5V to 5.5V 0.1%	-	5	-	μs
		V _I = 5.5V to 4.5V 0.1%				

Note 2: Slew rate is measured on rising and falling edges.



BLOCK DIAGRAM

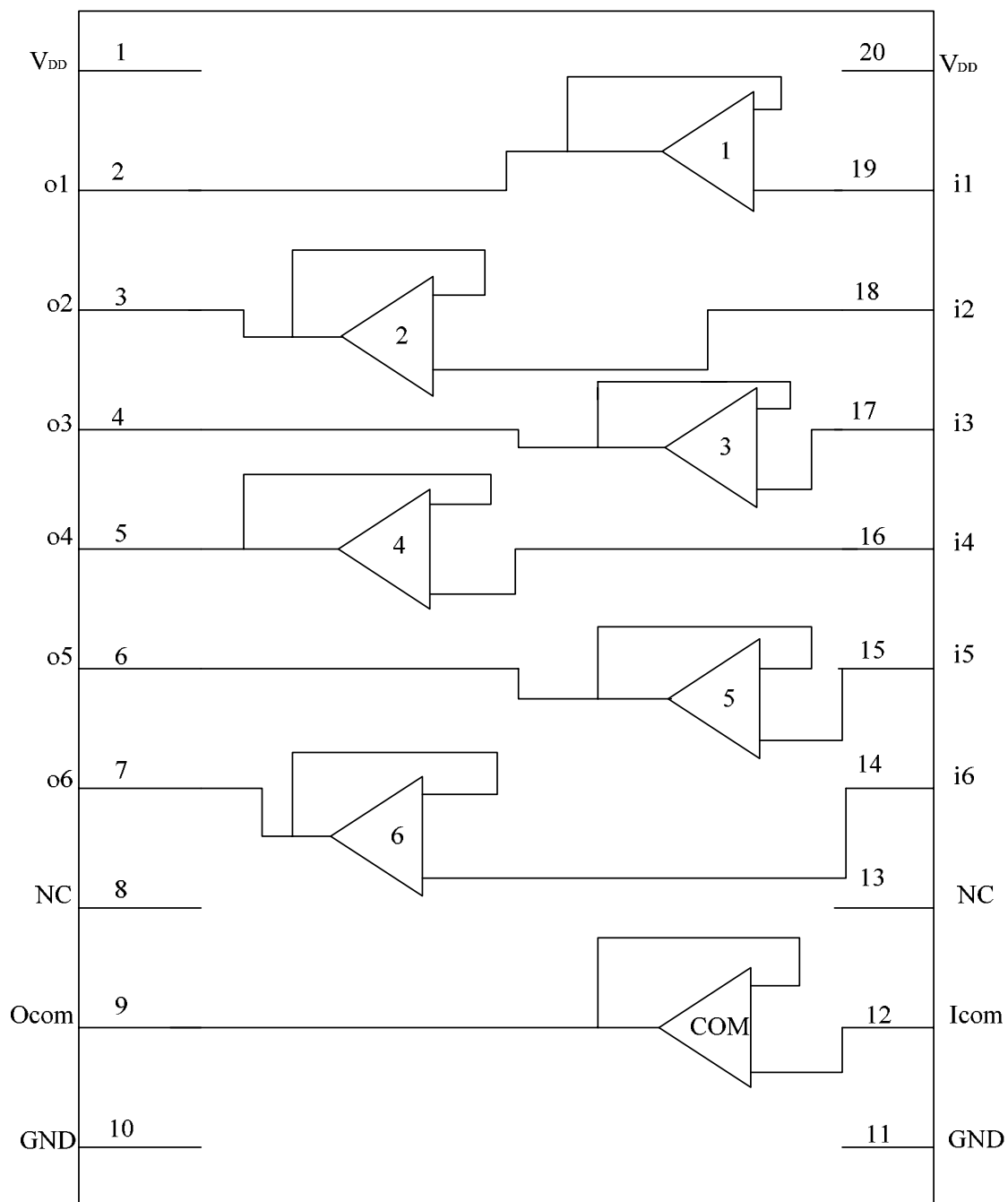



APPLICATION CIRCUIT

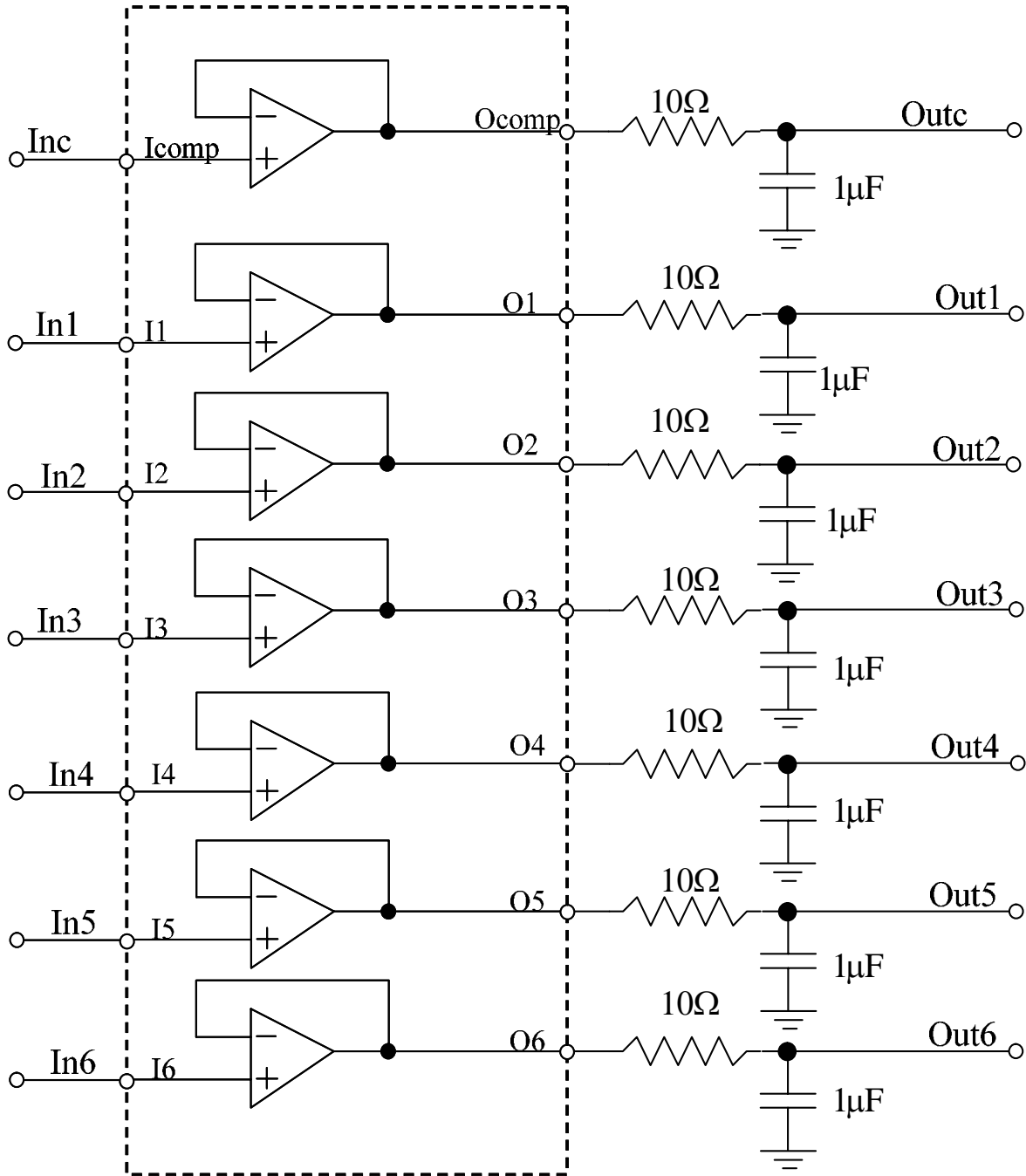



PACKAGE DIMENSION
TSSOP Power PAD-20

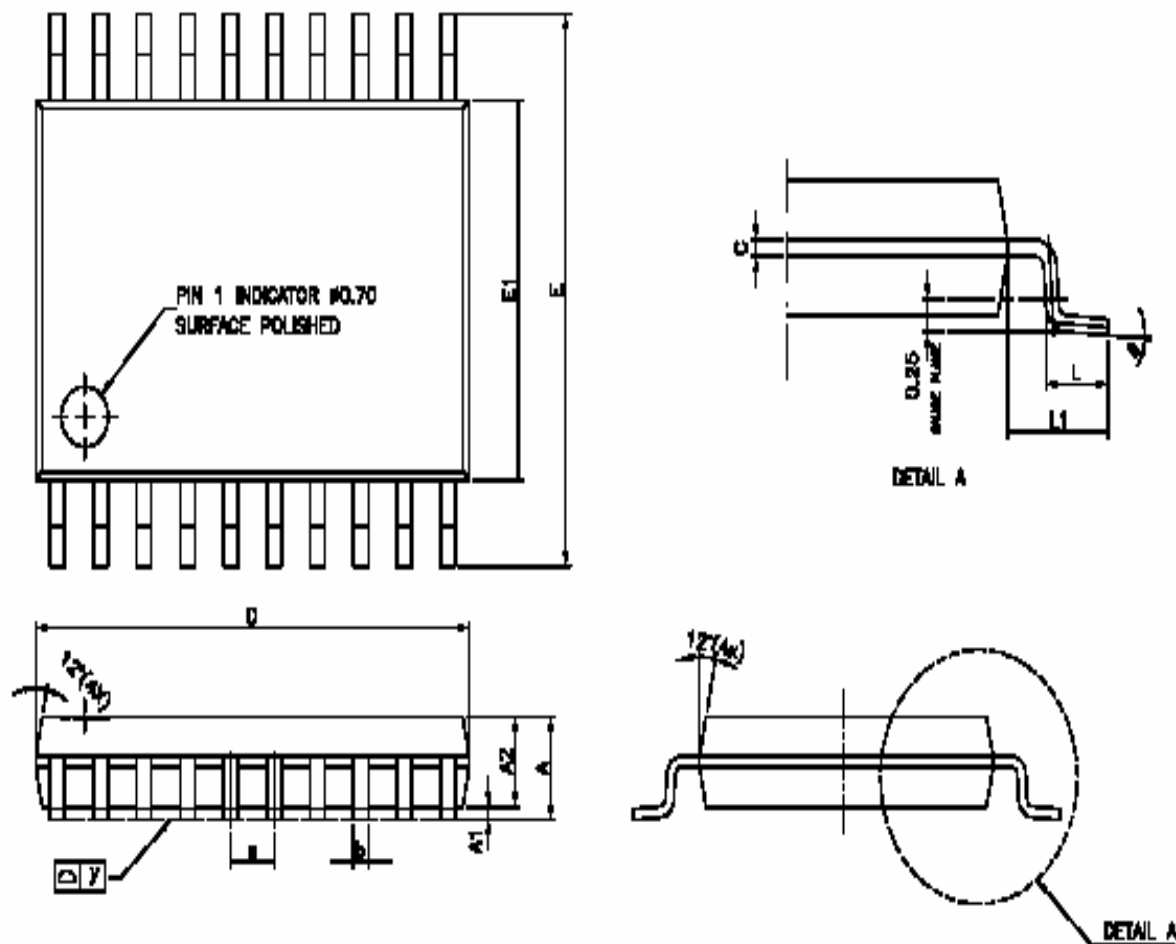

**PACKAGE DIMENSION (CONT.)****TSSOP Power PAD-20**

SYMBOL	DIMENSIONS IN MILLIMETERS			DIMENSIONS IN INCHES		
	MIN	TYP	MAX	MIN	TYP	MAX
A	---	---	1.20	---	---	0.047
A1	0.05	---	0.15	0.002	---	0.006
A2	0.08	1.00	1.05	0.003	0.039	0.041
b	0.19	---	0.30	0.007	---	0.012
C	0.09	---	0.20	0.0035	---	0.0080
D	6.40	6.50	6.60	0.252	0.256	0.260
E	---	6.40	---	---	0.252	---
E1	4.30	4.40	4.50	0.170	0.173	0.177
e	---	0.65	---	---	0.026	---
L	0.45	0.60	0.75	0.0177	0.0240	0.0295
L1	---	1.00	---	---	0.039	---
y	0°	---	8°	0°	---	8°
θ	---	---	0.076	---	---	0.003

Note:

1. CONTROLLING DIMENSION: MILLIMETERS
2. LEAD FRAME MATERIAL: OLIN C7025/EFTEC 64T
3. DIMENSION "D" DOES NOT INCLUDE MOLD FLASH, TIE BAR BURRS AND GATE BURRS. MOLD FLASH, TIE BURRS AND GATE BURRS SHALL NOT EXCEED 0.006" [0.15 MILLIMETERS] PER END. DIMENSION "E1" DOES NOT INCLUDE INTERLEAD FLASH. INTERLEAD FLASH SHALL NOT EXCEED 0.010" [0.25 MILLIMETERS] PER SIDE.
4. DIMENSION "b" DOES NOT INCLUDE DAMBAR PROTRUSION. ALLOWABLE DAMBAR PROTRUSION SHALL BE 0.003" [0.08 MILLIMETERS] TOTAL IN EXCESS OF THE "b" DIMENSION AT MAXIMUM MATERIAL CONDITION. DAMBAR CANNOT BE LOCATED ON THE LOWER RADIUS OR THE FOOT. MINIMUM SPACE BETWEEN PROTRUSION AND AN ADJACENT LEAD TO BE 0.0028" [0.07 MILLIMETERS]
5. TOLERANCE: ± 0.010" [0.25 MILLIMETERS] UNLESS OTHERWISE SPECIFIED
6. OTHERWISE DIMENSION FOLLOW ACCEPTABLE SPEC
7. REFERENCE DOCUMENT: JEDEC SPEC MO-153



PACKAGE DIMENSION
SOP20

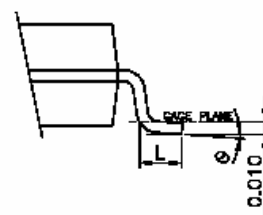
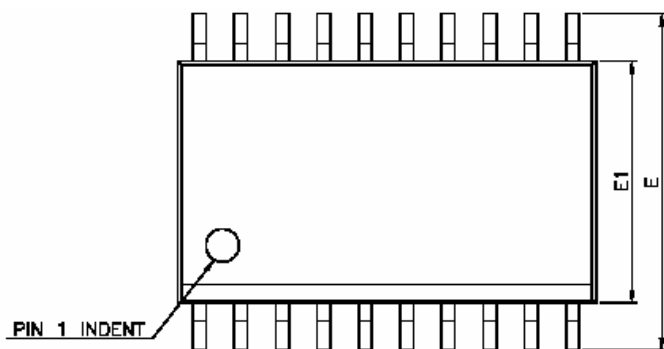

DETAIL A

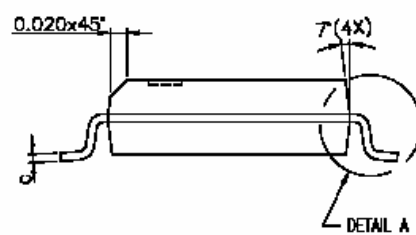
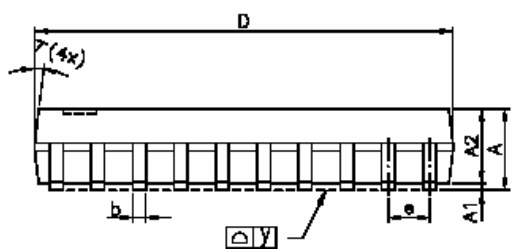

**PACKAGE DIMENSION (CONT.)**
SOP20

SYMBOL	DIMENSIONS IN MILLIMETERS			DIMENSIONS IN INCHES		
	MIN	TYP	MAX	MIN	TYP	MAX
A	2.36	2.49	2.64	0.093	0.098	0.104
A1	0.10	---	0.30	0.004	---	0.012
A2	---	2.31	---	---	0.091	---
b	0.33	0.41	0.51	0.013	0.016	0.020
C	0.18	0.23	0.28	0.007	0.009	0.011
D	12.60	12.80	12.90	0.496	0.504	0.508
E	10.01	10.31	10.64	0.394	0.406	0.419
E1	7.39	7.49	7.59	0.291	0.295	0.299
e	---	1.27	---	---	0.050	---
L	0.38	0.81	1.27	0.015	0.032	0.050
y	---	---	0.076	---	---	0.003
θ	0°	---	8°	0°	---	8°

Note:

1. CONTROLLING DIMENSION: INCH
2. LEAD FRAME MATERIAL: COPPER 194
3. DIMENSION "D" DOES NOT INCLUDE MOLD FLASH, TIE BAR BURRS AND GATE BURRS. MOLD FLASH, TIE BAR BURRS AND GATE BURRS SHALL NOT EXCEED 0.006" [0.15 MILLIMETERS] PER END. DIMENSION "E1" DOES NOT INCLUDE INTERLEAD FLASH. INTERLEAD FLASH SHALL NOT EXCEED 0.010" [0.25 MILLIMETERS] PER SIDE.
4. DIMENSION "b" DOES NOT INCLUDE DAMBAR PROTRUSION. ALLOWABLE DAMBAR PROTRUSION SHALL BE 0.003" [0.08 MILLIMETERS] TOTAL IN EXCESS OF THE "b" DIMENSION AT MAXIMUM MATERIAL CONDITION. DAMBAR CANNOT BE LOCATED ON THE LOWER RADIUS OR THE FOOT. MINIMUM SPACE BETWEEN PROTRUSION AND AN ADJACENT LEAD TO BE 0.0028" [0.07 MILLIMETERS]
5. TOLERANCE: ± 0.010 " [0.25 MILLIMETERS] UNLESS OTHERWISE SPECIFIED
6. OTHERWISE DIMENSION FOLLOW ACCEPTABLE SPEC
7. REFERENCE DOCUMENT: JEDEC SPEC MS-013



ORDERING INFORMATION

