

### DESCRIPTION

The Hynix HY5V62C is a 67,108,864-bit CMOS Synchronous DRAM, ideally suited for the memory applications which require wide data I/O and high bandwidth. HY5V62C is organized as 4banks of 524,288x32.

HY5V62C is offering fully synchronous operation referenced to a positive edge of the clock. All inputs and outputs are synchronized with the rising edge of the clock input. The data paths are internally pipelined to achieve very high bandwidth. All input and output voltage levels are compatible with LVTTTL.

Programmable options include the length of pipeline (Read latency of 2 or 3), the number of consecutive read or write cycles initiated by a single control command (Burst length of 1,2,4,8 or full page), and the burst count sequence(sequential or interleave). A burst of read or write cycles in progress can be terminated by a burst terminate command or can be interrupted and replaced by a new burst read or write command on any cycle. (This pipelined design is not restricted by a `2N` rule.)

### FEATURES

- JEDEC standard 3.3V power supply
- All device pins are compatible with LVTTTL interface
- 90Ball FBGA with 0.8mm of pin pitch
- All inputs and outputs referenced to positive edge of system clock
- Data mask function by DQM0,1,2 and 3
- Internal four banks operation
- Auto refresh and self refresh
- 4096 refresh cycles / 64ms
- Programmable Burst Length and Burst Type
  - 1, 2, 4, 8 or full page for Sequential Burst
  - 1, 2, 4 or 8 for Interleave Burst
- Programmable  $\overline{\text{CAS}}$  Latency ; 2, 3 Clocks
- Burst Read Single Write operation

### ORDERING INFORMATION

| Part No.   | Clock Frequency | Power  | Organization             | Interface | Package     |
|------------|-----------------|--------|--------------------------|-----------|-------------|
| HY5V62CF-7 | 143MHz          | Normal | 4Banks x 512Kbits<br>x32 | LVTTTL    | 90Ball FBGA |
| HY5V62CF-S | 100MHz          |        |                          |           |             |

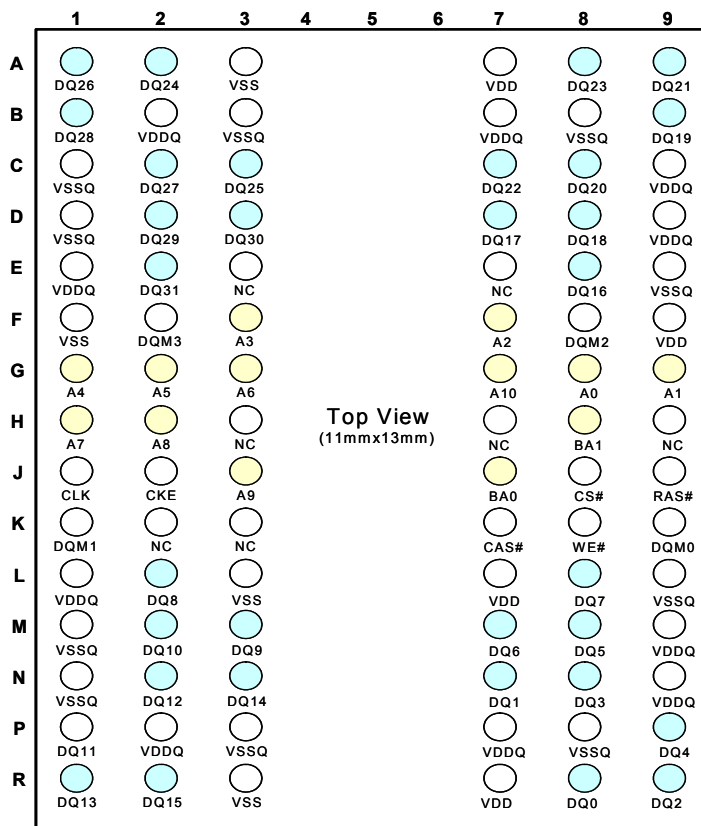
**PIN CONFIGURATION**

**PIN DESCRIPTION**

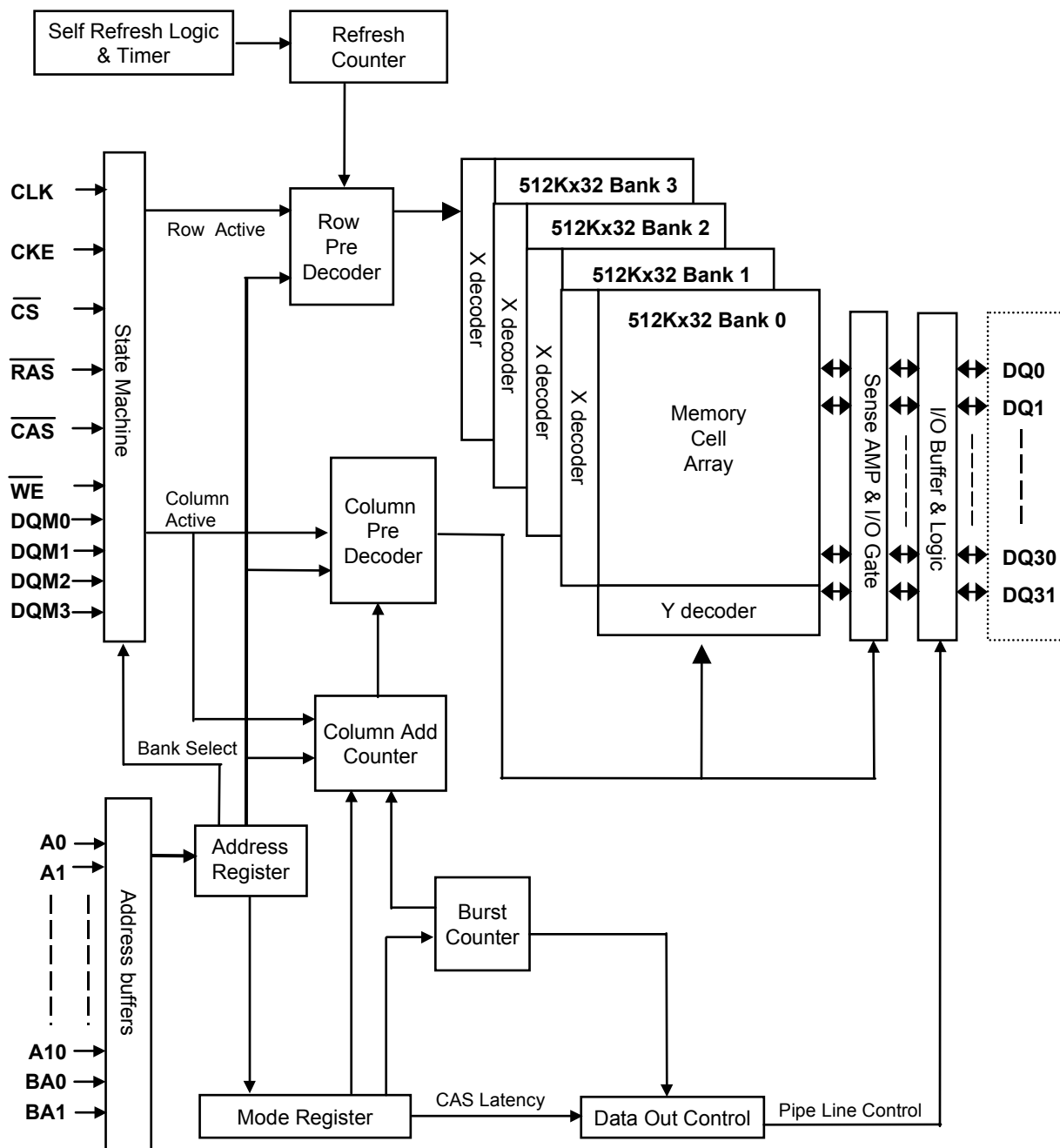
| PIN   | PIN NAME  | DESCRIPTION  |
|---|---|--|
| CLK   | Clock   | The system clock input. All other inputs are registered to the SDRAM on the rising edge of CLK.                                    |
| CKE   | Clock Enable  | Controls internal clock signal and when deactivated, the SDRAM will be one of the states among power down, suspend or self refresh |
| $\overline{CS}$                                       | Chip Select   | Enables or disables all inputs except CLK, CKE and DQM   |
| BA0, BA1  | Bank Address  | Selects bank to be activated during $\overline{RAS}$ activity<br>Selects bank to be read/written during CAS activity               |
| A0 ~ A10  | Address   | Row Address : RA0 ~ RA10, Column Address : CA0 ~ CA7<br>Auto-precharge flag : A10  |
| $\overline{RAS}$ , $\overline{CAS}$ , $\overline{WE}$ | Row Address Strobe,<br>Column Address Strobe,<br>Write Enable | $\overline{RAS}$ , $\overline{CAS}$ and $\overline{WE}$ define the operation<br>Refer function truth table for details             |
| DQM0~3  | Data Input/Output Mask  | Controls output buffers in read mode and masks input data in write mode  |
| DQ0 ~ DQ31  | Data Input/Output   | Multiplexed data input / output pin  |
| VDD/VSS   | Power Supply/Ground   | Power supply for internal circuits and input buffers   |
| VDDQ/VSSQ   | Data Output Power/Ground                                      | Power supply for output buffers  |
| NC  | No Connection   | No connection  |

**FUNCTIONAL BLOCK DIAGRAM**
**512Kbit x 4banks x 32 I/O Synchronous DRAM**

**ABSOLUTE MAXIMUM RATINGS**

| Parameter                          | Symbol    | Rating     | Unit     |
|------------------------------------|-----------|------------|----------|
| Ambient Temperature                | TA        | 0 ~ 70     | °C       |
| Storage Temperature                | TSTG      | -55 ~ 125  | °C       |
| Voltage on Any Pin relative to VSS | VIN, VOUT | -1.0 ~ 4.6 | V        |
| Voltage on VDD relative to VSS     | VDD, VDDQ | -1.0 ~ 4.6 | V        |
| Short Circuit Output Current       | IOS       | 50         | mA       |
| Power Dissipation                  | PD        | 1          | W        |
| Soldering Temperature · Time       | TSOLDER   | 260 · 10   | °C · Sec |

**Note :** Operation at above absolute maximum rating can adversely affect device reliability

**DC OPERATING CONDITION** (TA=0 to 70°C)

| Parameter            | Symbol    | Min        | Typ. | Max        | Unit | Note |
|----------------------|-----------|------------|------|------------|------|------|
| Power Supply Voltage | VDD, VDDQ | 3.0        | 3.3  | 3.6        | V    | 1,2  |
| Input high voltage   | VIH       | 2.0        | 3.0  | VDDQ + 0.3 | V    | 1,3  |
| Input low voltage    | VIL       | VSSQ - 0.3 | 0    | 0.8        | V    | 1,4  |

**Note :**

- 1.All voltages are referenced to VSS = 0V
- 2.VDD/VDDQ(min) is 3.15V for HY5V62CF-7/S
- 3.VIH (max) is acceptable 5.6V AC pulse width with  $\leq 3$ ns of duration with no input clamp diodes
- 4.VIL (min) is acceptable -2.0V AC pulse width with  $\leq 3$ ns of duration with no input clamp diodes

**AC OPERATING CONDITION** (TA=0 to 70°C, 3.0V  $\leq$  VDD  $\leq$  3.6V, VSS=0V - Note1)

| Parameter   | Symbol    | Value   | Unit | Note |
|---|-----------|---------|------|------|
| AC input high / low level voltage                   | VIH / VIL | 2.4/0.4 | V    |      |
| Input timing measurement reference level voltage    | Vtrip     | 1.4     | V    |      |
| Input rise / fall time                              | tR / tF   | 1       | ns   |      |
| Output timing measurement reference level           | Voutref   | 1.4     | V    |      |
| Output load capacitance for access time measurement | CL        | 30      | pF   | 2    |

**Note :**

- 1.3.15V  $\leq$  VDD  $\leq$  3.6V is applied for HY5V62CF-7/S
- 2.Output load to measure access times is equivalent to two TTL gates and one capacitor (30pF)  
For details, refer to AC/DC output load circuit

**CAPACITANCE** (TA=25°C, f=1MHz, VDD=3.3V)

| Parameter                       | Pin  | Symbol | Min | Max | Unit |
|---------------------------------|--|--------|-----|-----|------|
| Input capacitance               | CLK  | C11    | 2.5 | 3.5 | pF   |
|                                 | A0 ~ A10, BA0, BA1, CKE, $\overline{\text{CS}}$ , $\overline{\text{RAS}}$ , $\overline{\text{CAS}}$ , WE, DQM0~3 | C12    | 2.5 | 3.8 | pF   |
| Data input / output capacitance | DQ0 ~ DQ31   | C1/O   | 4   | 6.5 | pF   |

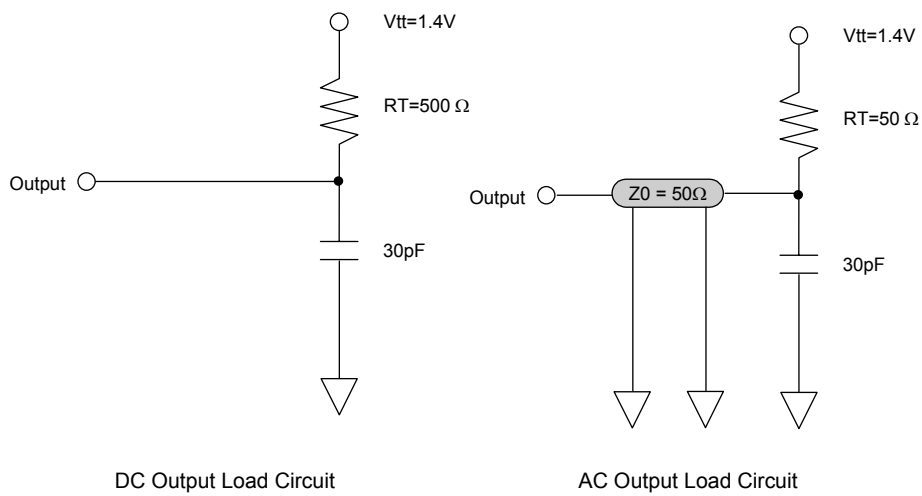
**OUTPUT LOAD CIRCUIT**

**DC CHARACTERISTICS I** (DC operating conditions unless otherwise noted)

| Parameter              | Symbol | Min. | Max | Unit | Note       |
|------------------------|--------|------|-----|------|------------|
| Input leakage current  | ILI    | -1   | 1   | uA   | 1          |
| Output leakage current | ILO    | -1   | 1   | uA   | 2          |
| Output high voltage    | VOH    | 2.4  | -   | V    | IOH = -2mA |
| Output low voltage     | VOL    | -    | 0.4 | V    | IOL = +2mA |

**Note :**

- 1.VIN = 0 to 3.6V, All other pins are not under test = 0V
- 2.DOUT is disabled, VOUT=0 to 3.6V

**DC CHARACTERISTICS II** (DC operating conditions unless otherwise noted)

| Parameter   | Symbol | Test Condition  | Speed |     | Unit | Note |   |
|---|--------|---|-------|-----|------|------|---|
|   |        |   | -7    | -S  |      |      |   |
| Operating Current                                   | IDD1   | Burst Length=1, One bank active<br>tRAS ≥ tRAS(min), tRP ≥ tRP(min),<br>IOL=0mA   | 120   | 115 | mA   | 1    |   |
| Precharge Standby Current<br>in power down mode     | IDD2P  | CKE ≤ VIL(max), tCK = 15ns  | 2     |     | mA   |      |   |
|   | IDD2PS | CKE ≤ VIL(max), tCK = ∞   | 2     |     |      |      |   |
| Precharge Standby Current<br>in non power down mode | IDD2N  | CKE ≥ VIH(min), $\overline{CS}$ ≥ VIH(min), tCK = 15ns<br>Input signals are changed one time during<br>2clks. All other pins ≥ VDD-0.2V or ≤ 0.2V | 15    |     | mA   |      |   |
|   | IDD2NS | CKE ≥ VIH(min), tCK = ∞<br>Input signals are stable.  | 10    |     |      |      |   |
| Active Standby Current<br>in power down mode        | IDD3P  | CKE ≤ VIL(max), tCK = 15ns  | 3     |     | mA   |      |   |
|   | IDD3PS | CKE ≤ VIL(max), tCK = ∞   | 3     |     |      |      |   |
| Active Standby Current<br>in non power down mode    | IDD3N  | CKE ≥ VIH(min), $\overline{CS}$ ≥ VIH(min), tCK = 15ns<br>Input signals are changed one time during<br>2clks. All other pins ≥ VDD-0.2V or ≤ 0.2V | 40    |     | mA   |      |   |
|   | IDD3NS | CKE ≥ VIH(min), tCK = ∞<br>Input signals are stable   | 25    |     |      |      |   |
| Burst Mode Operating<br>Current                     | IDD4   | tCK ≥ tCK(min),<br>tRAS ≥ tRAS(min), IOL=0mA<br>All banks active  | CL=3  | 210 | 180  | mA   | 1 |
|   |        |   | CL=2  | -   | 160  |      |   |
| Auto Refresh Current                                | IDD5   | tRRC ≥ tRRC(min), 2 banks active  | 210   | 190 | mA   | 2    |   |
| Self Refresh Current                                | IDD6   | CKE ≤ 0.2V  | 2     |     | mA   |      |   |

**Note :**

- 1.IDD1 and IDD4 depend on output loading and cycle rates. Specified values are measured with the output open
- 2.Min. of tRRC (Refresh RAS cycle time) is shown at AC CHARACTERISTICS I

**AC CHARACTERISTICS I** (AC operating conditions unless otherwise noted)

| Parameter                         |                                     | Symbol | -7  |      | -S  |      | Unit | Note |
|-----------------------------------|-------------------------------------|--------|-----|------|-----|------|------|------|
|                                   |                                     |        | Min | Max  | Min | Max  |      |      |
| System clock cycle time           | $\overline{\text{CAS}}$ Latency = 3 | tCK3   | 7   | 1000 | 10  | 1000 | ns   |      |
|                                   | $\overline{\text{CAS}}$ Latency = 2 | tCK2   | 10  |      | 12  |      | ns   |      |
| Clock high pulse width            |                                     | tCHW   | 2.5 | -    | 3   | -    | ns   | 1    |
| Clock low pulse width             |                                     | tCLW   | 2.5 | -    | 3   | -    | ns   | 1    |
| Access time from clock            | $\overline{\text{CAS}}$ Latency = 3 | tAC3   | -   | 5.4  | -   | 6    | ns   | 2    |
|                                   | $\overline{\text{CAS}}$ Latency = 2 | tAC2   | -   | 6    | -   | 8    | ns   |      |
| Data-out hold time                |                                     | tOH    | 2.7 | -    | 3   | -    | ns   | 3    |
| Data-Input setup time             |                                     | tDS    | 1.5 | -    | 2   | -    | ns   | 1    |
| Data-Input hold time              |                                     | tDH    | 0.8 | -    | 1   | -    | ns   | 1    |
| Address setup time                |                                     | tAS    | 1.5 | -    | 2   | -    | ns   | 1    |
| Address hold time                 |                                     | tAH    | 0.8 | -    | 1   | -    | ns   | 1    |
| CKE setup time                    |                                     | tCKS   | 1.5 | -    | 2   | -    | ns   | 1    |
| CKE hold time                     |                                     | tCKH   | 0.8 | -    | 1   | -    | ns   | 1    |
| Command setup time                |                                     | tCS    | 1.5 | -    | 2   | -    | ns   | 1    |
| Command hold time                 |                                     | tCH    | 0.8 | -    | 1   | -    | ns   | 1    |
| CLK to data output in low Z-time  |                                     | tOLZ   | 1.5 | -    | 2   | -    | ns   |      |
| CLK to data output in high Z-time | $\overline{\text{CAS}}$ Latency = 3 | tOHZ3  |     | 5.4  |     | 6    | ns   |      |
|                                   | $\overline{\text{CAS}}$ Latency = 2 | tOHZ2  |     |      | ns  |      |      |      |

**Note :**

1. Assume tR / tF (input rise and fall time ) is 1ns
2. Access times to be measured with input signals of 1v/ns edge rate, 0.8v to 2.0v
3. Data-out hold time to be measured under 30pF load condition, without Vt termination

**AC CHARACTERISTICS II** (AC operating conditions unless otherwise noted)

| Parameter  |                                      | Symbol | -7  |      | -S  |      | Unit | Note |
|--|--------------------------------------|--------|-----|------|-----|------|------|------|
|  |                                      |        | Min | Max  | Min | Max  |      |      |
| R $\overline{\text{AS}}$ cycle time                                    | Operation                            | tRC    | 62  | -    | 70  | -    | ns   |      |
|  | Auto Refresh                         | tRRC   | 62  | -    | 70  | -    | ns   |      |
| R $\overline{\text{AS}}$ to C $\overline{\text{AS}}$ delay             |                                      | tRCD   | 20  | -    | 20  | -    | ns   |      |
| R $\overline{\text{AS}}$ active time                                   |                                      | tRAS   | 42  | 120K | 50  | 120K | ns   |      |
| R $\overline{\text{AS}}$ precharge time                                |                                      | tRP    | 20  | -    | 20  | -    | ns   |      |
| R $\overline{\text{AS}}$ to R $\overline{\text{AS}}$ bank active delay |                                      | tRRD   | 14  | -    | 20  | -    | CLK  |      |
| C $\overline{\text{AS}}$ to C $\overline{\text{AS}}$ delay             |                                      | tCCD   | 1   | -    | 1   | -    | CLK  |      |
| Write command to data-in delay   |                                      | tWTL   | 0   | -    | 0   | -    | CLK  |      |
| Data-in to precharge command   |                                      | tDPL   | 1   | -    | 1   | -    | CLK  |      |
| Data-in to active command  |                                      | tDAL   | 4   | -    | 3   | -    | CLK  |      |
| DQM to data-out Hi-Z   |                                      | tDQZ   | 2   | -    | 2   | -    | CLK  |      |
| DQM to data-in mask  |                                      | tDQM   | 0   | -    | 0   | -    | CLK  |      |
| MRS to new command   |                                      | tMRD   | 1   | -    | 1   | -    | CLK  |      |
| Precharge to data output Hi-Z  | C $\overline{\text{AS}}$ Latency = 3 | tPROZ3 | 3   | -    | 3   | -    | CLK  |      |
|  | C $\overline{\text{AS}}$ Latency = 2 | tPROZ2 | 2   | -    | 2   | -    | CLK  |      |
| Power down exit time   |                                      | tPDE   | 1   | -    | 1   | -    | CLK  |      |
| Self refresh exit time   |                                      | tSRE   | 1   | -    | 1   | -    | CLK  | 1    |
| Refresh Time   |                                      | tREF   | -   | 64   | -   | 64   | ms   |      |

**Note :**

1. A new command can be given tRRC after self refresh exit



**DEVICE OPERATING OPTION TABLE**
**HY5V62CF-7**

|                      | <b>CAS Latency</b> | <b>tRCD</b> | <b>tRAS</b> | <b>tRC</b> | <b>tRP</b> | <b>tAC</b> | <b>tOH</b> |
|----------------------|--------------------|-------------|-------------|------------|------------|------------|------------|
| <b>143MHz(7ns)</b>   | 3CLKs              | 3CLKs       | 6CLKs       | 9CLKs      | 3CLKs      | 5.4ns      | 2.7ns      |
| <b>133MHz(7.5ns)</b> | 3CLKs              | 3CLKs       | 6CLKs       | 9CLKs      | 3CLKs      | 5.4ns      | 2.7ns      |
| <b>100MHz(10ns)</b>  | 2CLKs              | 2CLKs       | 5CLKs       | 7CLKs      | 2CLKs      | 6ns        | 3ns        |

**HY5V62CF-S**

|                     | <b>CAS Latency</b> | <b>tRCD</b> | <b>tRAS</b> | <b>tRC</b> | <b>tRP</b> | <b>tAC</b> | <b>tOH</b> |
|---------------------|--------------------|-------------|-------------|------------|------------|------------|------------|
| <b>100MHz(10ns)</b> | 2CLKs              | 2CLKs       | 5CLKs       | 7CLKs      | 2CLKs      | 6ns        | 3ns        |
| <b>83MHz(12ns)</b>  | 2CLKs              | 2CLKs       | 5CLKs       | 7CLKs      | 2CLKs      | 6ns        | 3ns        |
| <b>66MHz(15ns)</b>  | 2CLKs              | 2CLKs       | 4CLKs       | 6CLKs      | 2CLKs      | 6ns        | 3ns        |

**COMMAND TRUTH TABLE**

| Command                   | CKEn-1 | CKEn | $\overline{CS}$ | $\overline{RAS}$ | $\overline{CAS}$ | $\overline{WE}$ | DQM | ADDR    | A10/<br>AP | BA | Note |
|---------------------------|--------|------|-----------------|------------------|------------------|-----------------|-----|---------|------------|----|------|
| Mode Register Set         | H      | X    | L               | L                | L                | L               | X   | OP code |            |    |      |
| No Operation              | H      | X    | H               | X                | X                | X               | X   | X       |            |    |      |
|                           |        |      | L               | H                | H                | H               |     |         |            |    |      |
| Bank Active               | H      | X    | L               | L                | H                | H               | X   | RA      |            | V  |      |
| Read                      | H      | X    | L               | H                | L                | H               | X   | CA      | L          | V  |      |
| Read with Autoprecharge   |        |      |                 |                  |                  |                 |     |         | H          |    |      |
| Write                     | H      | X    | L               | H                | L                | L               | X   | CA      | L          | V  |      |
| Write with Autoprecharge  |        |      |                 |                  |                  |                 |     |         | H          |    |      |
| Precharge All Banks       | H      | X    | L               | L                | H                | L               | X   | X       | H          | X  |      |
| Precharge selected Bank   |        |      |                 |                  |                  |                 |     |         | L          | V  |      |
| Burst Stop                | H      | X    | L               | H                | H                | L               | X   | X       |            |    |      |
| DQM                       | H      | X    |                 |                  |                  |                 | V   | X       |            |    |      |
| Auto Refresh              | H      | H    | L               | L                | L                | H               | X   | X       |            |    |      |
| Self Refresh <sup>1</sup> | Entry  | H    | L               | L                | L                | L               | H   | X       | X          |    |      |
|                           | Exit   | L    | H               | H                | X                | X               | X   | X       |            |    |      |
| L                         |        |      |                 | H                | H                | H               |     |         |            |    |      |
| Precharge power down      | Entry  | H    | L               | H                | X                | X               | X   | X       | X          |    |      |
|                           |        |      |                 | L                | H                | H               | H   |         |            |    |      |
| Exit                      | L      | H    | L               | H                | X                | X               | X   | X       | X          |    |      |
|                           |        |      |                 | L                | H                | H               | H   |         |            |    |      |
| Clock Suspend             | Entry  | H    | L               | H                | X                | X               | X   | X       | X          |    |      |
|                           |        |      |                 | L                | V                | V               | V   |         |            |    |      |
| Exit                      | L      | H    | X               |                  |                  |                 | X   |         |            |    |      |

**Note :**

1. Exiting Self Refresh occurs by asynchronously bringing CKE from low to high
2. X = Don't care, H = Logic High, L = Logic Low. BA =Bank Address, RA = Row Address, CA = Column Address, Opcode = Operand Code, NOP = No Operation

PACKAGE INFORMATION

