



Obsolescence Notice

This product is obsolete.

This information is available for your convenience only.

For more information on Zarlink's obsolete products and replacement product lists, please visit http://products.zarlink.com/obsolete_products/

The SL5162 multistandard modulator up-converts a baseband video signal with separate audio frequency input on to a VHF or UHF carrier up to 860MHz. It provides RF signals with negative or positive video modulation and AM or FM sound subcarrier to satisfy both PAL/NTSC and SECAM applications.

The on-chip local oscillator uses an external resonator tank which may be controlled via any Mitel 1.3GHz synthesiser. Selection of both video and sound standards are provided by level switching of a single pin.

A video AGC circuit is provided to ensure constant modulation depth. In PAL mode this may be disabled and a white clip circuit switched in to prevent overmodulation if desired.

FEATURES

- Covers both Negative and Positive Modulation Systems
- Internal AGC with Disable
- Control of Sound and Video Standard via Single Pin
- Symmetrical 75Ω RF Outputs for Low Radiation
- Audio Input with AM/FM Sound Modulator
- Switchable Video Test Signal Generator (TSG)
- Intercarrier Input for Second Sound Channel
- ESD Protection

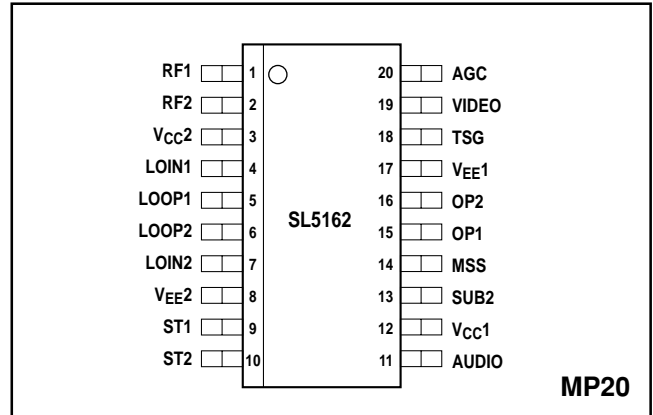

Figure 1 Pin connections – top view

ORDERING INFORMATION

SL5162/KG/MP1S Miniature plastic package
SL5162/KG/MP1T Tape and reel

ABSOLUTE MAXIMUM RATINGS

Storage temperature	-55°C to +150°C
Junction temperature	-20°C to +150°C
Ambient temperature	-10°C to +80°C
Supply Voltage	-0.3V to +7.0 V
Voltage at any other pin	-0.3V to +7.0V

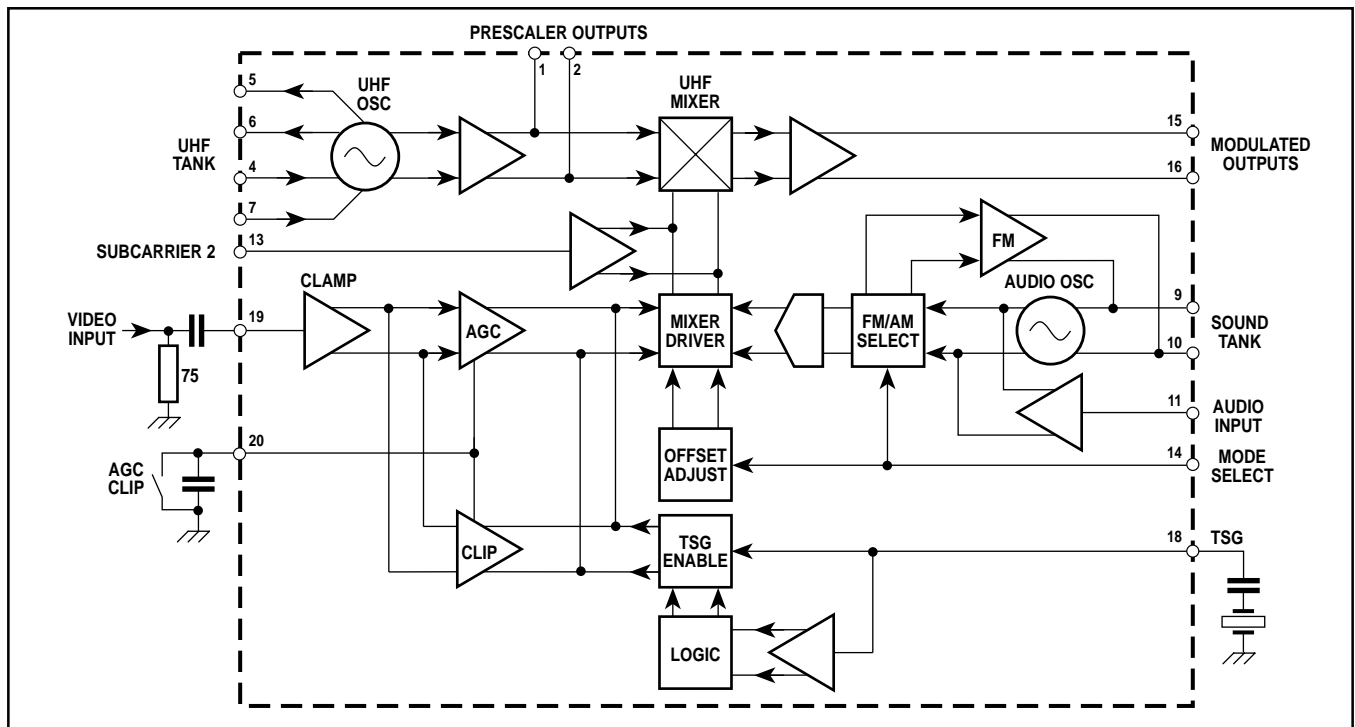

Figure 2 Block diagram

ELECTRICAL CHARACTERISTICS

$T_{AMB} = +25^{\circ}\text{C}$ (operating range -10°C to $+80^{\circ}\text{C}$), $V_{CC} = +5\text{V}$, (operating range $+4.5$ to $+5.5\text{V}$). Max and Min values are guaranteed by either production test or design. They apply within the specified temperature and supply voltage ranges unless otherwise stated.

Characteristic	Pin	Value			Units	Conditions
		Min.	Typ.	Max.		
Supply Voltage	3, 12	4.5		5.5	V	
Supply current	3, 12		45	53	mA	
Video Input	19					
Video input level (V_P)		0.5	1.0	1.5	Vp-p	$V_P = \text{sync to white level, AGC disabled (note 1)}$
Eff. white clip level (V_C)			1.17		V	$V_P = \text{sync to white level, AGC enabled}$
Input impedance			100		k Ω	$V_C = \text{sync to limit level (note 2)}$
Video bandwidth -1 dB		10			MHz	Except for duration of clamp pulse
-3 dB		25			MHz	
Video SNR weighted		60	62		dB	CCIR Rec 451-1 (note 3), mono sound system
Differential gain			± 2	± 5	%	
Differential phase			± 2	± 5	deg	
Line tilt (black level)				0.5	%	Dependent upon video input clamp capacitor
Clamp accuracy				5	mV	$V_P = 1.0\text{V} \Delta$ (black level with and without input video)
Audio Input	11					
Input impedance			25		k Ω	
Audio bandwidth (-1 dB)		15			kHz	
Subcarrier frequency		4		7	MHz	Determined by external components.
FM THD			0.5	1.0	%	In demodulated signal. Input signal = 1 kHz sinewave at $\pm 35\text{kHz}$ deviation
Intercarrier Input	13					
Input level			140		mVp-p	To define -22dBC (peak carrier)
FM Performance	11					
Audio input for 100% deviation ($\pm 35\text{kHz}$)			100		mVp-p	At device input
FM deviation sensitivity			0.7		kHz/mV	Audio input 1kHz sinewave
Max frequency deviation		250			kHz	No pre-emphasis, dependent on external components
AM Performance Audio	11					
Modulation depth			80		%	Input = 200mVp-p at 1kHz
Audio SNR (wideband)		>46			dB	
RF Output	1, 2					
Peak vision carrier:						
SECAM (L)			83		dB μ V	$V_P = 1.0\text{V}$, sync = 0.3V
PAL			84		dB μ V	Differential 75 Ω output
Flatness band 470-860MHz				2	dB	
APL Δ				± 2	%	APL 10-90%
White Level, Nominal	1, 2					
Negative modulation		12	17	22	%	Relative to peak vision carrier (PVC), $V_P = 1.0\text{V}$, all systems (note 4)
Sync Tip	1,2					
Negative modulation			100		%	All systems
Positive modulation			6		%	
Sync degradation (+ve mod)			1		%	$D_{\text{SYNC}} + (1 \pm \frac{S}{W} \times \frac{7}{3} \times 100)$

NOTES

1. This is the nominal input level to provide the preset video modulation index for the selected standard. Any variation from the nominal level will change the RF modulation index.
2. The actual clip level is set relative to the input video level. The level of 1.17V only applies if the video input signal is correctly proportioned. The white clip circuit operates only when the AGC is disabled.
3. Measured at CH38 with R&S EMFP demodulator and UAF Video Analyser.
4. Measured at CH21 with R&S EMFP reference demodulator and UAF Video Analyser. Synchronous demodulation.

ELECTRICAL CHARACTERISTICS (continued)

Characteristic	Pin	Value			Units	Conditions
		Min.	Typ.	Max.		
Mod Index Control						
Sound subcarrier level, negative video modulation			-16		dBC	Relative to PVC (note 4)
Sound subcarrier level, positive video modulation			-15		dBC	Relative to PVC, with no audio modulation applied
Second sound subcarrier			-22		dBC	Relative to PVC
Video Test Sig. Generator	18					
Negative impedance			-3		k Ω	
Ceramic resonator impedance			500			
Prescaler	1, 2					
Output amplitude			30		mVp-p	Single ended from 50 Ω
Distortions						
Intermodulation:						Values referred to PAL system G carrier level Note 5
$f_V + (f_S - f_C)$			-70		dBC	
$f_V + 2f_C$			-70		dBC	
$f_V + 2f_S$			-70		dBC	
$f_V + 3f_S$			-75		dBC	
Spurious (in band)			-70		dBC	
Spurious (ex band)			-70		dBC	
Harmonics:						
$2f_V$		-10			dBC	
$3f_V$		-10			dBC	
Sound in vision		-60			dBC	Relative to 83dB μ V modulated carrier (note 6)
Vision in sound		-46			dBC	
Local Oscillator	4,5,6,7					
Frequency range		38.9		860	MHz	
Residual FM				0.2	kHz	With 1Vp-p video input signal colour bars

NOTES

5. f_V = vision carrier, f_S = sound subcarrier, f_C = chroma subcarrier.

6. SUB 2 must be connected to V_{CC} to achieve this performance.

Pin	Name	Function
1	RF 1	UHF prescaler output 1
2	RF 2	UHF prescaler output 2
3	V_{CC2}	Positive supply for UHF circuits
4	LOIN 1	UHF tank
5	LOOP 1	UHF tank
6	LOOP 2	UHF tank
7	LOIN 2	UHF tank
8	V_{EE2}	UHF ground
9	ST 1	Sound tank 1
10	ST2	Sound tank 2
11	AUDIO	Audio 1 input
12	V_{CC1}	Positive supply for baseband circuits
13	SUB 2	Intercarrier (sound) input
14	MSS	Video modulation/standard select
15	OP 1	75 Ω modulated output
16	OP2	75 Ω modulated output
17	V_{EE1}	Baseband ground
18	TSG	Test signal generator input
19	VID	Video input
20	AGC	AGC capacitor/disable switch

Table 1 Pin descriptions

VIDEO INPUT SECTION

A composite signal of the selected standard is applied to the device via a coupling capacitor also acting as the clamp storage capacitor. A minimum level clamp is used to DC restore the video signal in the IC to an internally defined reference voltage.

The AGC will give a constant output level with input signals between 0.5 and 1.5 Vp-p. If a controlled 1Vp-p video signal is available, the AGC may be disabled, in which case a white clip circuit is switched in, to prevent possible overmodulation.

Selection of negative or positive modulation is via a single pin (14). The voltage on this pin controls an offset which is fed to the UHF mixer, thus determining both modulation depth, and sense of modulation.

SOUND SECTION

The sound is AC coupled and AM or FM modulated onto the pre-selected carrier, 4.5 - 6.5MHz; its level is nominally at -16dB relative to the peak vision carrier.

UHF MODULATED OUTPUT

Modulation and relative levels of vision and sound carrier levels are preset for the selected broadcast standard. Table 2 gives the output options available. Modulation index is fixed at 83% for all negative modulation systems and at 94% for SECAM standard L. Selection of sound tank frequency is defined by off-chip tank components.

Standard	Video		Sound		
	Modulation	Mod. index (%)	SC freq. (MHz)	Modulation	Pre-emphasis (μ s)
NTSC (M)	Negative	83	4.5	FM	75
PAL (G)	Negative	83	5.5	FM	50
PAL (I)	Negative	83	6.0	FM	50
SECAM (L)	Positive	94	6.5	AM	Through

Table 2 Video modulation/standard selection

TEST SIGNAL GENERATOR (TSG)

The internal test signal generator is driven from a 500kHz ceramic resonator. The TSG waveform is shown in Figure 3 and has an effective input video amplitude of 1V sync tip to white. Note that when TSG is enabled, the sound subcarrier modulation is disabled and so the audio is muted.

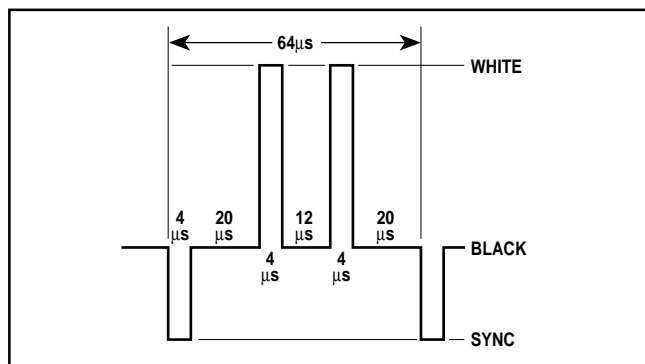

Figure 3 TSG waveform

APPLICATION NOTES

The key to achieving acceptable modulator performance is to ensure a well planned circuit layout with good RF decoupling of all supplies and sensitive pins. Ground loops should be avoided or kept as small as possible since RF coupling is the single most important characteristic in degrading modulator performance. Where possible, double sided board with a ground plane should be used and care taken to decouple all sensitive pins as close to the device as possible.

Oscillator Design and Layout

The oscillator layout should be kept as small as possible to minimise parasitics. It is also recommended that the ground plane is kept as far away from the oscillator itself since this will minimise the unwanted capacitance from the tank components to the ground plane. This has two advantages:

1. It increases the oscillator tuning range
2. It minimises the amount of RF coupled into the ground plane by the oscillator.

The circuit diagram shown in Figure 4 can be used for UHF or VHF applications. Surface mount components should be used wherever possible since these will minimise parasitics and also allow a more compact circuit design. For applications at VHF the values of the tuning components must be modified: the coupling capacitors should be increased to a value of 2.2pF or greater. For fixed frequency applications up to 100MHz (or limited tuning range applications) 15pF coupling capacitors can be used. Varactor tuning of the SL5162 should not be attempted unless the oscillator is synthesised, due to the wide temperature variation of varactor diodes. The application shown in Figure 4 uses a Mitel 1.3GHz TV synthesiser. This provides the required stability and tuning for the VCO. Any of the of the Mitel Media Products I²C and 3-wire bus synthesisers such as SP5611, SP5502, SP5026 should be suitable for use with the SL5162

Modulated Outputs

The routing of the modulated outputs requires special attention since these are particularly vulnerable to coupling from the VCO: unwanted coupling of the LO frequency to the RF output will modify the modulation depth. Typically, in instances where RF coupling is present, the amount of coupling (and the phase) will vary as the oscillator is tuned across the band, causing the modulation index to be either higher or lower than the situation where no RF coupling is present. Thus the modulation index will vary as the device is tuned from one channel to another. For VHF and other applications below 500MHz, oscillator coupling is not such an issue, however similar care should still be taken with the layout in order to maximise device performance.

Use of a Balun

It is possible to further improve device performance with the use of a balun to remove the effects of common mode coupling. Although using a balun will add to component cost, it may be the best way to achieve maximum performance at higher frequencies where common mode noise has made it impossible to achieve the required SNR or dynamic range in the output signal. A low cost balun wound on a ferrite bead former should be sufficient to provide adequate performance in the majority of applications.

Sound Tank Circuit

It is recommended that the sound tank shown in Figure 4 is used. For PAL G, NTSC or SECAM applications, the value of the inductor may be modified to achieve the required subcarrier frequency. The tank circuit can be tuned between 4MHz and 7MHz. The sound subcarrier is automatically gain controlled to a value which gives a 16dB picture-to-sound carrier ratio when the SL5162 is set to negative modulation. The audio input signal is AC coupled through pin 11. The FM sensitivity of the of the sound section is 0.7kHz/mV, therefore a 140mVp-p input signal should give a \pm 50kHz deviation of the sound subcarrier.

Stereo Sound

For stereo applications, a previously modulated second subcarrier should be input via the SUB 2 input (pin 13). For example, with the German Panda system, this would normally be at 5.74MHz. An input level of 200mV p-p should provide the required picture carrier/sound carrier ratio of 22dB.

Video Modulation/Standard Selection

The SL5162 may be switched between negative and positive modulation standards via MSS, pin 14. This configures both the sense of video modulation (negative or positive), and switches the modulation on the sound subcarrier to AM when positive video modulation is selected. These standards are switched as shown in Table 3. To ensure reliable startup over the entire V_{CC} range it is recommended that the sound tank circuit is started via an effective pulse from the I²C bus synthesiser used in the system. This is shown in the demonstration board circuit, Figure 4. To do this, one of the

open collector outputs is initially turned on. This is then released when the mode selection (PAL/NTSC or SECAM) is made or at any other convenient point (e.g. when frequency data is sent) in PAL/NTSC mode. As an example, to synthesise 471.25MHz send the data words as shown in Table 4.

Care must be taken to ensure that the MSS pin is adequately decoupled as close to the pin as possible. The routing of any control line to this pin should also be laid out to ensure

MSS pin voltage	Video modulation	Audio modulation
0V	Negative	FM
5V	Positive	AM

Table 3

Data word	Description
C2	Address synthesiser
1D	MSB frequency information
74	LSB frequency information
CE	Charge pump high mode, standard operation
B0	Turn on port 5 to switch sound tank on
CE	Resend of byte 4
10	Turn on port 5, turn off port 4 (to configure SL5162 to PAL/NTSC operation)
STOP	Stop bit (if required)

Table 4

Circuit ref.	Value	Type
R1	22k Ω	Surface mount 1206
R2	22k Ω	Surface mount 1206
R4	10k Ω	Surface mount 1206
R5	22k Ω	Surface mount 1206
R7	47k Ω	Surface mount 1206
R8	1.6k Ω	Surface mount 1206
R9	75 Ω	Surface mount 1206
R10*	75 Ω	Surface mount 1206
R11*	0 Ω	Surface mount 0805
R12	0 Ω	Surface mount 1206
R13	10k Ω	Surface mount 1206
C1	18pF	Surface mount 0805 100V COG
C2	100pF	Surface mount 1206
C3	100pF	Surface mount 1206
C4	220nF	Surface mount 1206
C5	47nF	Surface mount 1206
C6	10nF	Surface mount 1206
C7	-	BB515 varactor diode
C8	5.6pF	Surface mount 0805
C9	100pF	Surface mount 0805
C10	10nF	Surface mount 1206

*Not fitted

maximum separation from the LO components whilst still remaining as short as possible. In PAL/NTSC (mono) applications, pin 13 (SUB 2) may be left open circuit or decoupled to ground via a 1nF capacitor. In SECAM (mono) applications pin 13 must be directly connected to V_{CC} to disable the intercarrier sound circuitry. For optimum performance it is recommended that in single ended output applications, pin15 is used for positive modulation, and pin 16 used for negative modulation.

Test Signal Generator (TSG)

A TSG is provided which may be enabled by connecting a 500kHz ceramic resonator via a 56pF capacitor to the TSG pin (pin 18) as shown in Figure 4. The TSG is disabled by connecting pin 18 to ground. The waveform that the TSG produces (shown in Figure 3) will create two white bars on a standard TV screen. It should be noted that standard (video) modulation depth specification for the SL5162 in its normal application does not apply to the TSG facility, since it is only intended as a tuning or test mode.

AGC/White Clip

The SL5162 is provided with an AGC circuit which should ensure correct modulation depth provided a composite video signal between 0.5V and 1.5V sync tip to peak white is applied to the VIDEO input, pin 19. If desired, the AGC may be disabled and a white clip circuit switched in to prevent overmodulation. This clipping level is set to a nominal 17% above peak white level, thus ensuring that even with a standard PAL I 95% saturated, 100% amplitude colour bars test signal, no clipping should take place. The AGC is enabled by connecting the pin 20 to Ground via a 150nF capacitor; white clip is enabled by connecting a 1.6k Ω resistor from pin 20 to ground.

Circuit ref.	Value	Type
C11	10nF	Surface mount 1206
C12	10nF	Surface mount 1206
C13	150pF	Surface mount 1206
C14	33nF	Surface mount 1206
C15	47 μ F	Electrolytic 0.1 inch pitch
C16	150nF	Surface mount 1206 (X7R)
C17	680nF	0.2 inch pitch leaded capacitor
C18	56pF	Surface mount 1206
C19	10nF	Surface mount 0805
C20	10nF	Surface mount 0805
C21	100pF	Surface mount 1206
C22	1 μ F	Electrolytic 0.1 inch pitch
C23	10nF	Surface mount 1206
C24	220nF	Surface mount 1206
C25	100pF	Surface mount 1206
C26	100pF	Surface mount 1206
C27	1.5pF	Surface mount 0603
C28	1.5pF	Surface mount 0603
C29	1.5pF	Surface mount 0603
C30	1.5pF	Surface mount 0603

contd...

Table 5 SL5162 demonstration board components parts list

SL5162

Circuit ref.	Value	Type
SK1-4	-	BNC straight square socket
P1-2	-	3-way PCB header
P5	-	2-way PCB header
LK1	-	Link
SW1	-	2×SPST DIL switch
IC1	-	Mitel SP5611
IC2	-	Mitel SL5162

Circuit ref.	Value	Type
TR1	-	NPN transistor, BCW31, SOT23
L1	5-6 μ H	TOKO choke
L2	-	1 turn 5mm diameter 22 SWG
L3	-	2 turns 5mm diameter 22 SWG
X1	4MHz	IQD crystal
X2	500kHz	Ceramic resonator

Table 5 SL5162 demonstration board components parts list (continued)

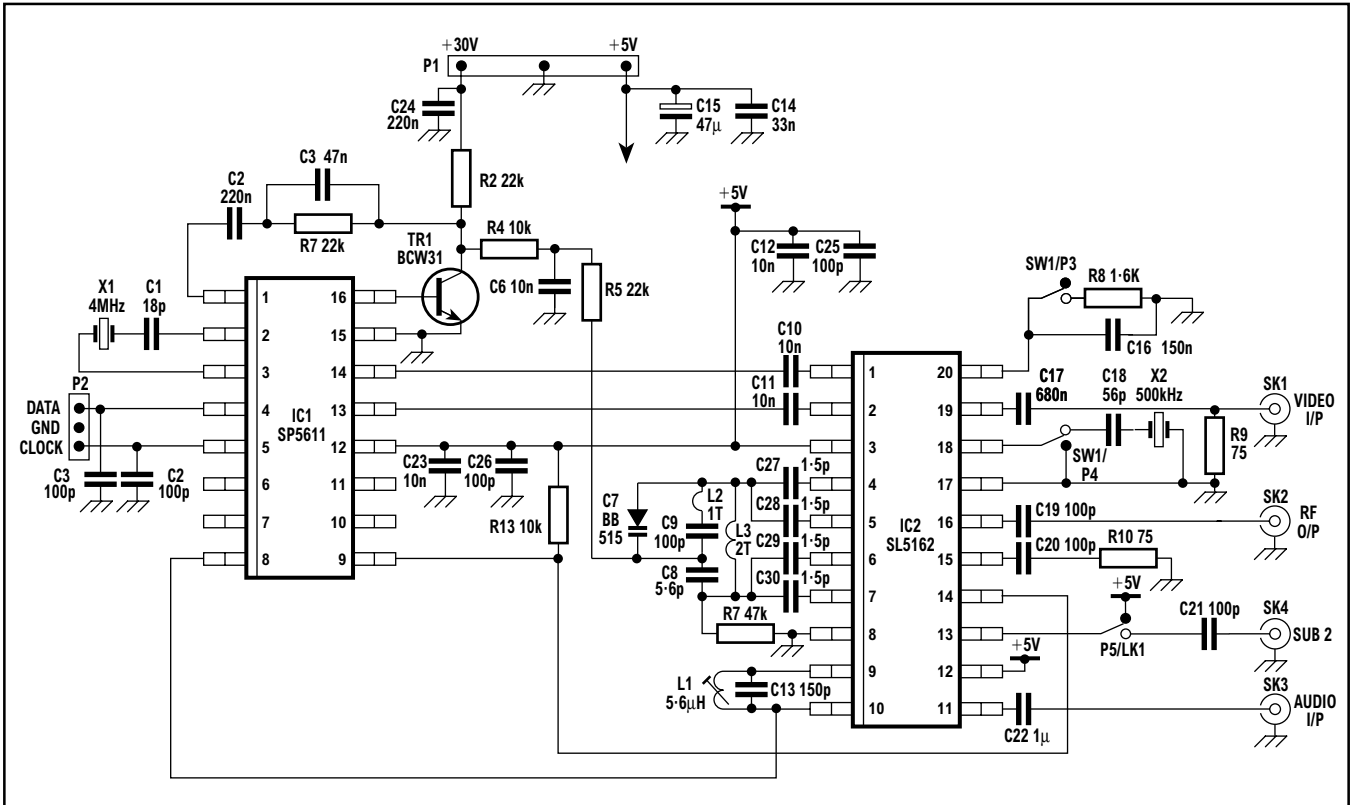

Figure 4 SL5162 demonstration board

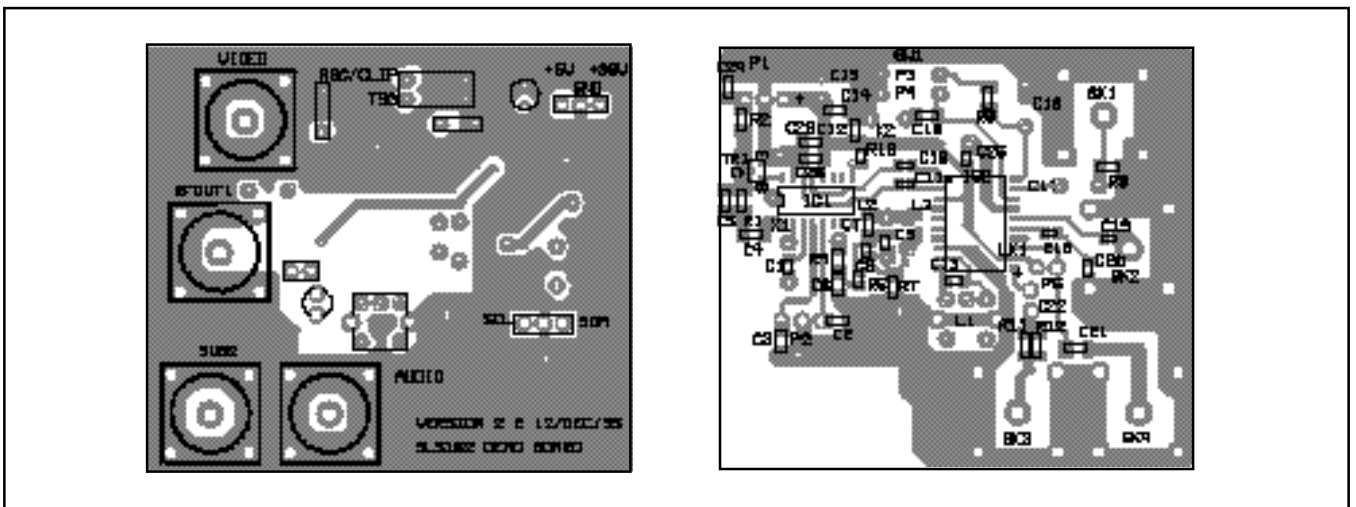

Figure 5 Demonstration board layout

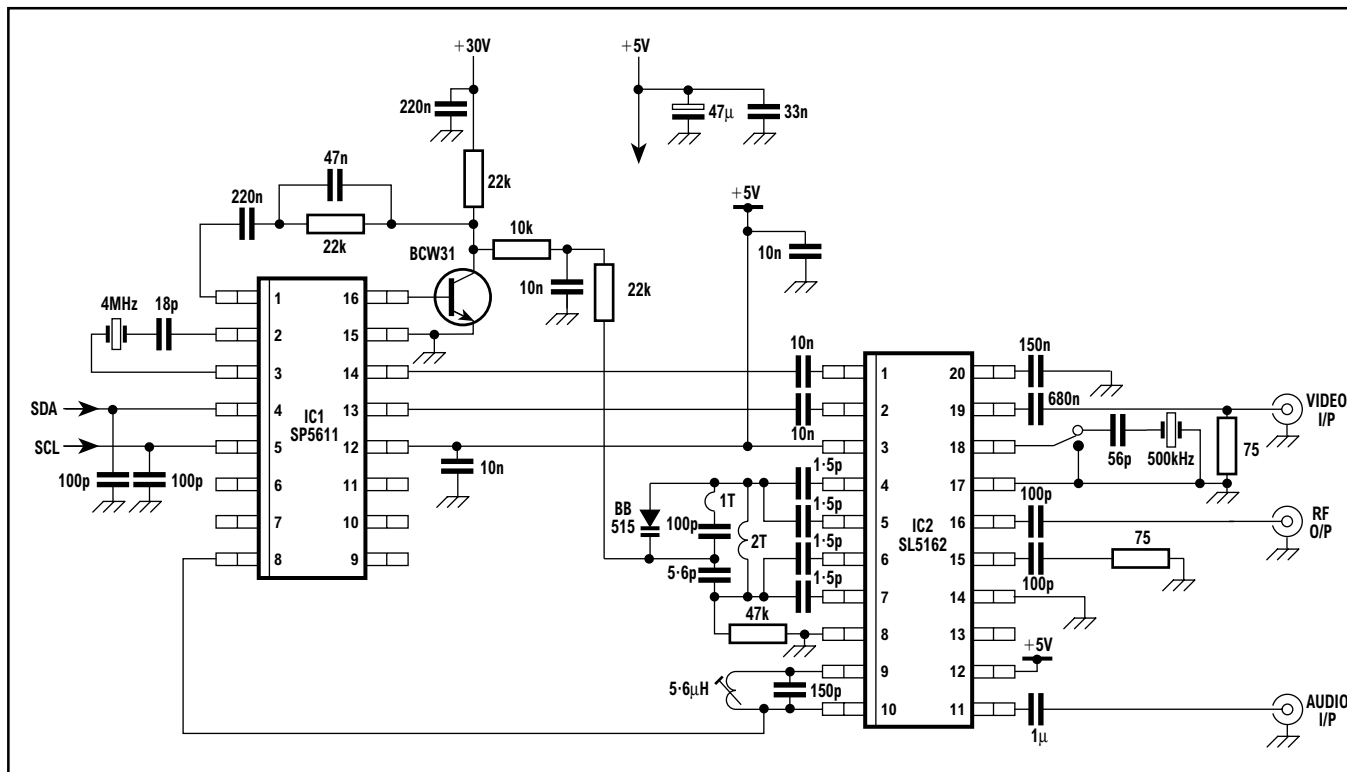

Figure 6 PAL (mono) application

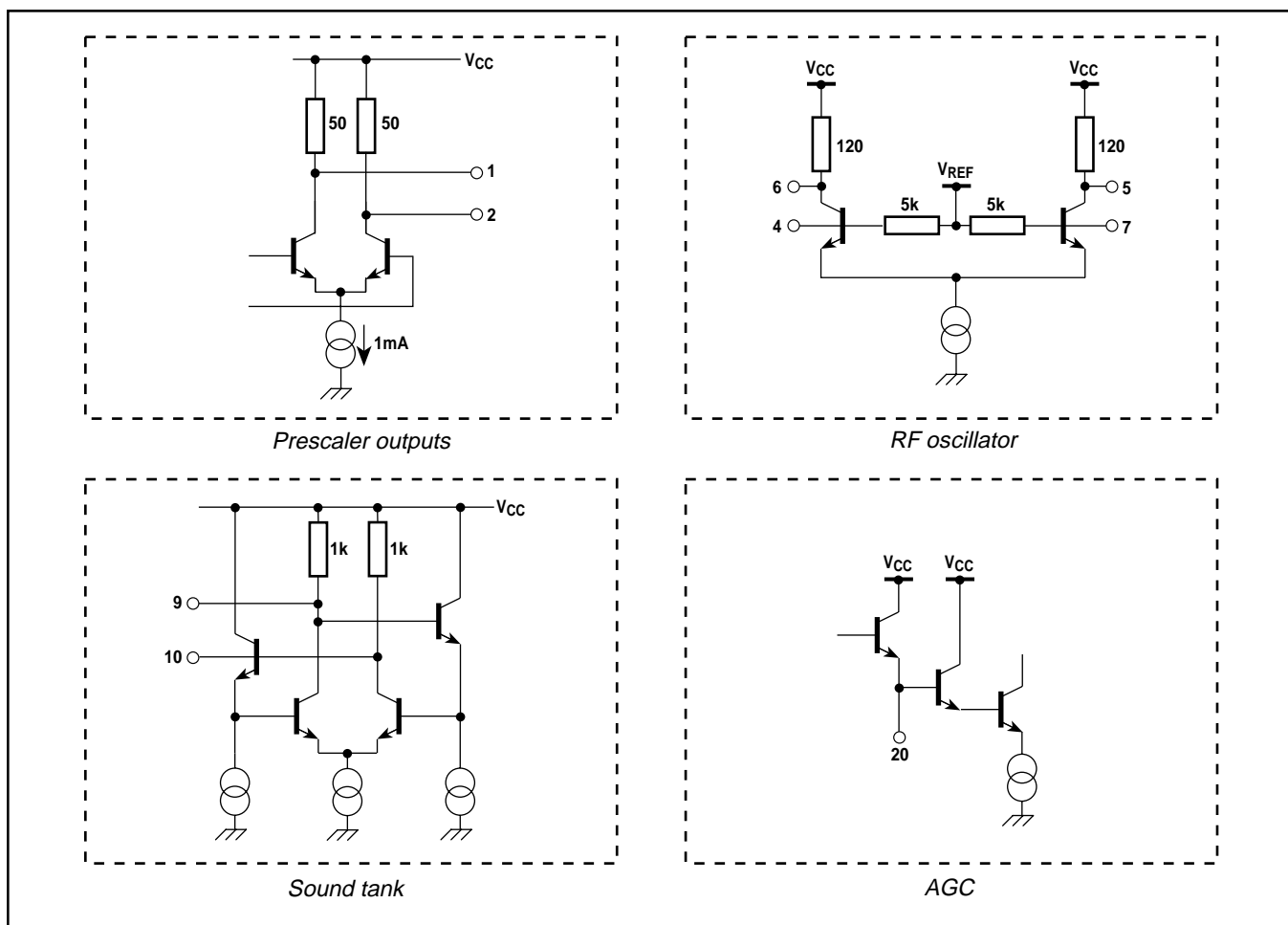

Figure 7 I/O interface circuits

contd...

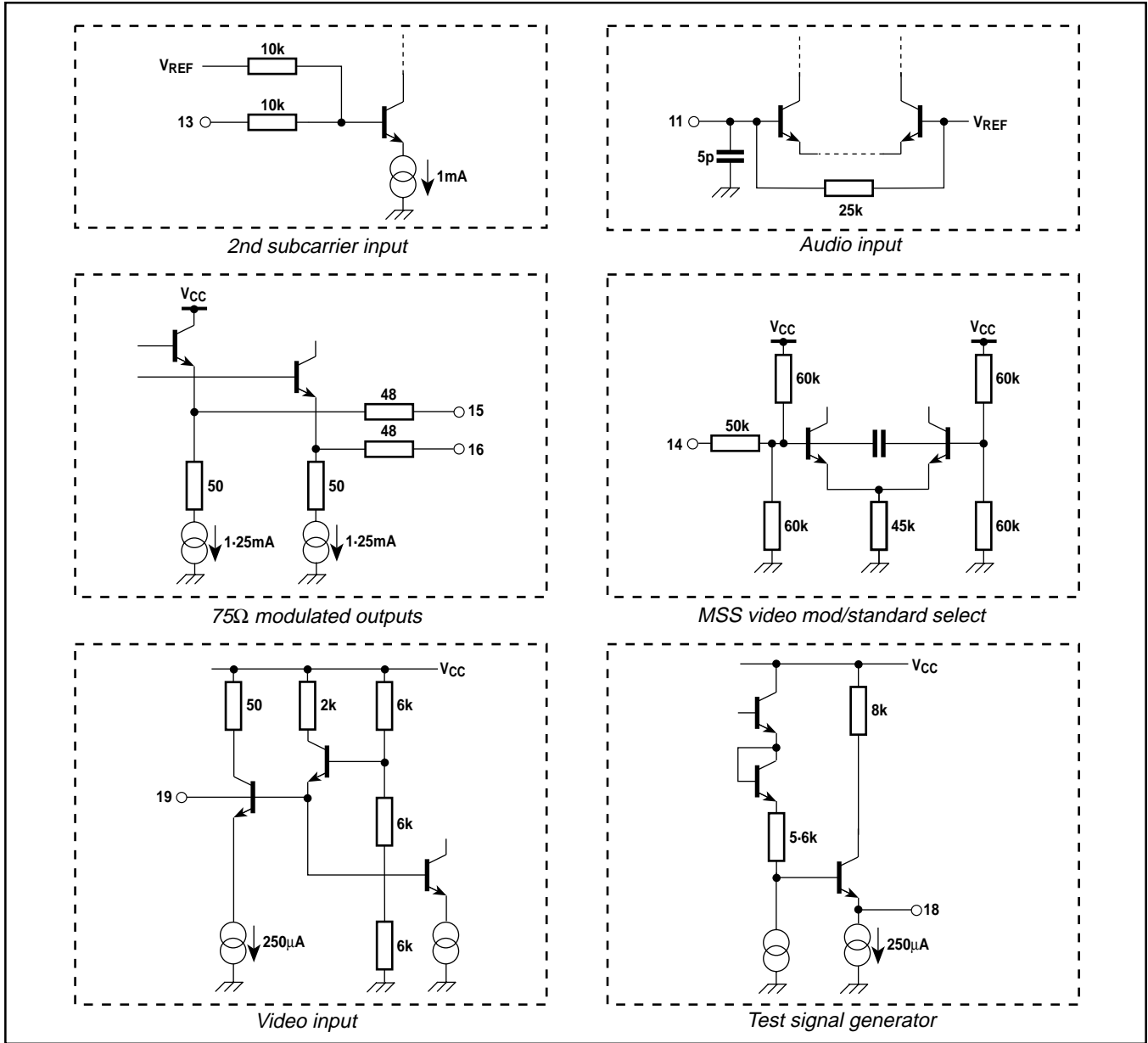

Figure 7 I/O interface circuits (continued)



Internet: <http://www.mitelsemi.com>

CUSTOMER SERVICE CENTRES

- **FRANCE & BENELUX** Les Ulis Cedex
Tel: (1) 69 18 90 00 Fax: (1) 64 46 06 07
- **GERMANY** Munich Tel: (089) 419508-20 Fax: (089) 419508-55
- **ITALY** Milan Tel: (02) 6607151 Fax: (02) 66040993
- **JAPAN** Tokyo Tel: (03) 5276-5501 Fax: (03) 5276-5510
- **KOREA** Seoul Tel: (2) 5668141 Fax: (2) 5697933
- **NORTH AMERICA** Scotts Valley, USA
Tel: (408) 438 2900 Fax: (408) 438 5576/6231

- **SOUTH EAST ASIA** Singapore
Tel: (65) 333 6193 Fax: (65) 333 6192
- **SWEDEN** Stockholm Tel: 46 8 702 97 70 Fax: 46 8 640 47 36
- **TAIWAN, ROC** Taipei Tel: 886 2 25461260 Fax: 886 2 27190260
- **UK, EIRE, DENMARK, FINLAND & NORWAY**
Swindon Tel: (01793) 726666 Fax: (01793) 518582

These are supported by Agents and Distibutors in major countries worldwide.

© Mitel 1998 Publication No. DS4497 Issue No. 3.0 September 1998 TECHNICAL DOCUMENTATION – NOT FOR RESALE. PRINTED IN UNITED KINGDOM

This publication is issued to provide information only which (unless agreed by the Company in writing) may not be used, applied or reproduced for any purpose nor form part of any order or contract nor to be regarded as a representation relating to the products or services concerned. No warranty or guarantee express or implied is made regarding the capability, performance or suitability of any product or service. The Company reserves the right to alter without prior notice the specification, design or price of any product or service. Information concerning possible methods of use is provided as a guide only and does not constitute any guarantee that such methods of use will be satisfactory in a specific piece of equipment. It is the user's responsibility to fully determine the performance and suitability of any equipment using such information and to ensure that any publication or data used is up to date and has not been superseded. These products are not suitable for use in any medical products whose failure to perform may result in significant injury or death to the user. All products and materials are sold and services provided subject to the Company's conditions of sale, which are available on request.

All brand names and product names used in this publication are trademarks, registered trademarks or trade names of their respective owners.



**For more information about all Zarlink products
visit our Web Site at
www.zarlink.com**

Information relating to products and services furnished herein by Zarlink Semiconductor Inc. or its subsidiaries (collectively "Zarlink") is believed to be reliable. However, Zarlink assumes no liability for errors that may appear in this publication, or for liability otherwise arising from the application or use of any such information, product or service or for any infringement of patents or other intellectual property rights owned by third parties which may result from such application or use. Neither the supply of such information or purchase of product or service conveys any license, either express or implied, under patents or other intellectual property rights owned by Zarlink or licensed from third parties by Zarlink, whatsoever. Purchasers of products are also hereby notified that the use of product in certain ways or in combination with Zarlink, or non-Zarlink furnished goods or services may infringe patents or other intellectual property rights owned by Zarlink.

This publication is issued to provide information only and (unless agreed by Zarlink in writing) may not be used, applied or reproduced for any purpose nor form part of any order or contract nor to be regarded as a representation relating to the products or services concerned. The products, their specifications, services and other information appearing in this publication are subject to change by Zarlink without notice. No warranty or guarantee express or implied is made regarding the capability, performance or suitability of any product or service. Information concerning possible methods of use is provided as a guide only and does not constitute any guarantee that such methods of use will be satisfactory in a specific piece of equipment. It is the user's responsibility to fully determine the performance and suitability of any equipment using such information and to ensure that any publication or data used is up to date and has not been superseded. Manufacturing does not necessarily include testing of all functions or parameters. These products are not suitable for use in any medical products whose failure to perform may result in significant injury or death to the user. All products and materials are sold and services provided subject to Zarlink's conditions of sale which are available on request.

Purchase of Zarlink's I²C components conveys a licence under the Philips I²C Patent rights to use these components in and I²C System, provided that the system conforms to the I²C Standard Specification as defined by Philips.

Zarlink, ZL and the Zarlink Semiconductor logo are trademarks of Zarlink Semiconductor Inc.

Copyright Zarlink Semiconductor Inc. All Rights Reserved.

TECHNICAL DOCUMENTATION - NOT FOR RESALE
