

DATA SHEET

NE57611

Single cell Li-ion battery charger

Product data
Supersedes data of 2002 Dec 10

2003 Oct 15

Single cell Li-ion battery charger

NE57611

DESCRIPTION

The NE57611 is a one-cell, Li-ion battery charger controller which includes constant-current and constant voltage charging, a precise charge termination, and precharging of undervoltage cells.

It contains the minimum circuitry needed to safely charge a lithium-ion or lithium-polymer cell. This makes it good for very compact, portable applications.

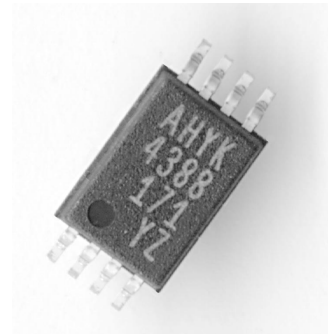

FEATURES

- 30 mV per cell charging accuracy from 0 °C to +50 °C
- Low quiescent current (250 μ A – ON; 2 μ A – OFF)
- Undervoltage precharge detector
- Self-discharge maintenance charging

APPLICATIONS

- Cellular telephones
- Personal Digital Assistants
- Other 1-cell Li-ion portable applications

SIMPLIFIED SYSTEM DIAGRAM

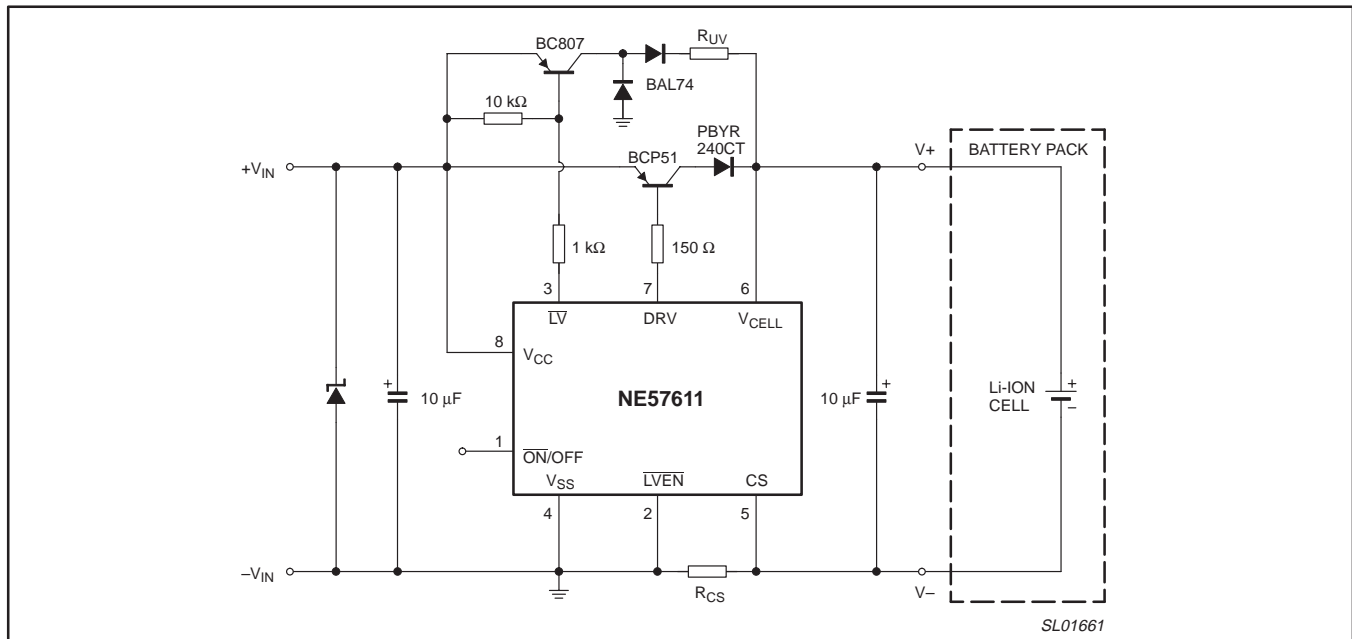

Figure 1. Simplified system diagram.

Single cell Li-ion battery charger

NE57611

ORDERING INFORMATION

TYPE NUMBER	PACKAGE		TEMPERATURE RANGE
	NAME	DESCRIPTION	
NE57611BDH	VSOP-8A (TSSOP)	plastic thin shrink small outline package; 8 leads; body width 4.4 mm	-20 to +70 °C

PIN CONFIGURATION

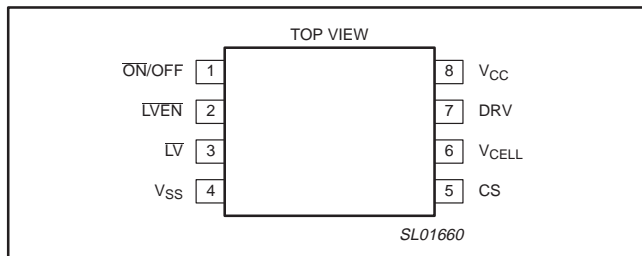

Figure 2. Pin configuration.

PIN DESCRIPTION

PIN	SYMBOL	DESCRIPTION
1	$\overline{\text{ON/OFF}}$	$\overline{\text{ON/OFF}}$ control input pin for the IC. $\overline{\text{ON/OFF}} = V_{\text{CC}}$: OFF $\overline{\text{ON/OFF}} = \text{GND}$: ON
2	$\overline{\text{LVEN}}$	Low voltage detection circuit ON/OFF control. $\overline{\text{LVEN}} = V_{\text{CC}}$: OFF $\overline{\text{LVEN}} = \text{GND}$: ON
3	LV	Low cell voltage detection circuit output pin. Open collector; Active-LOW.
4	V_{SS}	Connect to negative pole of battery.
5	CS	Current detection pin. Detects current by drop in external resistor voltage and controls rated current. Current value can be set at 0.1 V/R1 typ.
6	V_{CELL}	Battery voltage input pin. Detects battery voltage and controls rated voltage to the prescribed voltage value.
7	DRV	Charging control output pin drives external PNP-Transistor to control charging.
8	V_{CC}	Power supply input pin.

MAXIMUM RATINGS

SYMBOL	PARAMETER	MIN.	MAX.	UNIT
$V_{\text{CC(max)}}$	Power supply voltage	-0.3	+18	V
$V_{\text{CEL(max)}}$	Maximum cell voltage	-0.3	+13	V
$V_{\overline{\text{LVEN}}}$	$\overline{\text{LVEN}}$ input voltage	-0.3	$V_{\text{CC}} + 0.3$	V
$V_{\overline{\text{ON/OFF}}}$	$\overline{\text{ON/OFF}}$ input voltage	-0.3	$V_{\text{CC}} + 0.3$	V
T_{opr}	Operating ambient temperature	-20	+70	°C
T_{stg}	Storage temperature	-40	+125	°C
P_{D}	Power dissipation	-	300	mW

Single cell Li-ion battery charger

NE57611

ELECTRICAL CHARACTERISTICS $T_{amb} = 25\text{ °C}$, $V_{IN} = 5\text{ V}$, unless otherwise specified.

SYMBOL	PARAMETER	CONDITIONS	MIN.	TYP.	MAX.	UNIT
I_{CC1}	Consumption current 1	$\overline{ON}/OFF = \overline{LVEN} = 0\text{ V}$ (Charge: ON)	–	250	400	μA
I_{CC2}	Consumption current 2	$\overline{ON}/OFF = \overline{LVEN} = V_{CC}$ (Charge: OFF)	–	2	10	μA
V_{OV1}	Output voltage 1	$T_{amb} = 25\text{ °C}$	4.100	4.125	4.150	V
V_{OV2}	Output voltage 2	$T_{amb} = 0\text{ °C to }50\text{ °C}$	4.095	4.125	4.155	V
V_{CL}	Current limit		90	100	110	mV
I_{CEL1}	Leakage current between V_{CELL} -CS during operation		3.0	5.0	7.0	μA
I_{CEL2}	Leak current between V_{CELL} -CS	$V_{CC} = 0\text{ V}$ or OPEN	–	0.01	1	μA
$\overline{I}_{ON/OFF}$	\overline{ON}/OFF input current		–	20	30	μA
V_{L1}	\overline{ON}/OFF input voltage L	Charge: ON	–0.3	–	2.0	V
V_{H1}	\overline{ON}/OFF input voltage H	Charge: OFF	$V_{CC} - 1.0$	–	$V_{CC} + 0.3$	V
$V_{UV(CELL)}$	Low voltage detection voltage		2.0	2.15	2.3	V
\overline{I}_{LVEN}	\overline{LVEN} input current		–	20	30	μA
V_{L2}	\overline{LVEN} input voltage L	Low voltage detection circuit: ON	–0.3	–	2.0	V
V_{H2}	\overline{LVEN} input voltage H	Low voltage detection circuit: OFF	$V_{CC} - 1.0$	–	$V_{CC} + 0.3$	V
I_{LV}	Low voltage detection		–	–	0.5	μA
V_{LV}	output leak current Low voltage detection	$I_{SINK} = 1\text{ mA}$	–	0.2	0.4	V
I_{DRV}	output saturation voltage DRV pin inflow current		10	20	–	mA
V_{DRV}	DRV pin output voltage	For no load	0.3	–	$V_{CC} - 0.3$	V

NOTES:

1. Please insert a capacitor of several μF between power supply and ground when using.
2. Be sure that CS pin potential does not fall below -0.5 V .
3. If the IC is damaged and control is no longer possible, its safety cannot be guaranteed. Please protect with something other than this IC.

Single cell Li-ion battery charger

NE57611

TECHNICAL DISCUSSION

Lithium cell safety

Lithium-ion and lithium-polymer cells have a higher energy density than that of nickel-cadmium or nickel metal hydride cells and have a much lighter weight. This makes the lithium cells attractive for use in portable products. However, lithium cells require a protection circuit within the battery pack because certain operating conditions can be hazardous to the battery or the operator, if allowed to continue.

Lithium cells have a porous carbon or graphite anode where lithium ions can lodge themselves in the pores. The lithium ions are separated, which avoids the hazards of metallic lithium.

If the lithium cell is allowed to become overcharged, metallic lithium plates out onto the surface of the anode and volatile gas is generated within the cell. This creates a rapid-disassembly hazard (the battery ruptures). If the cell is allowed to over-discharge (V_{CELL} less than approximately 2.3 V), then the copper metal from the cathode goes into the electrolyte solution. This shortens the cycle life of the cell, but presents no safety hazard. If the cell experiences excessive charge or discharge currents, as happens if the wrong charger is used, or if the terminals short circuit, the internal series resistance of the cell creates heating and generates the volatile gas which could rupture the battery.

The protection circuit continuously monitors the cell voltage for an **overcharged condition** or an **overdischarged condition**. It also continuously monitors the output for an **overcurrent condition**. If any of these conditions are encountered, the protection circuit opens a series MOSFET switch to terminate the abnormal condition. The lithium cell protection circuit is placed within the battery pack very close to the cell.

Charging control versus battery protection

The battery pack industry does not recommend using the pack's internal protection circuit to end the charging process. The external battery charger should have a charge termination circuit in it, such

as that provided by the NE57611. This provides two levels of overcharge protection, with the primary protection of the external charge control circuit and the back-up protection from the battery pack's protection circuit. The charge termination circuit will be set to stop charging at a level around 50 mV less than the overvoltage threshold voltage of the battery pack's own protection circuit.

Lithium cell operating characteristics

The internal resistance of lithium cells is in the 100 mΩ range, compared to the 5–20 mΩ of the nickel-based batteries. This makes the Lithium-ion and polymer cells better for lower battery current applications (less than 1 ampere) as found in cellular and wireless telephones, palmtop and laptop computers, etc.

The average operating voltage of a lithium-ion or polymer cell is 3.6 V as compared to the 1.2 V of NiCd and NiMH cells. The typical discharge curve for Lithium cell is shown in Figure 3.

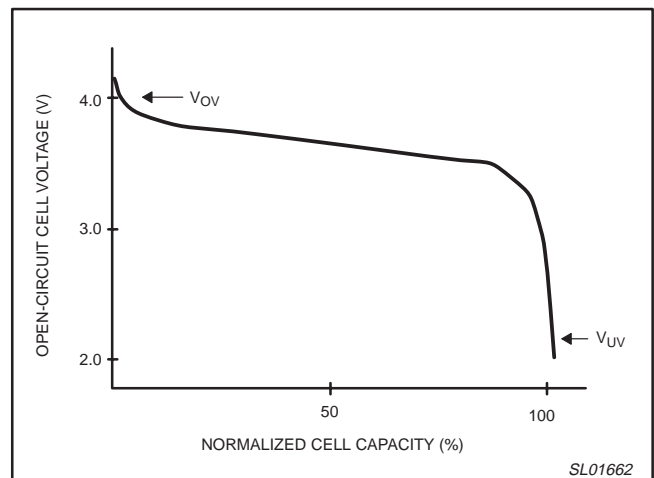

Figure 3. Lithium discharge curve.

Single cell Li-ion battery charger

NE57611

Charging Lithium cells

The lithium cells must be charged with a dedicated charging IC such as the NE57600. These dedicated charging ICs perform a current-limited, constant-voltage charge, as shown in Figure 4.

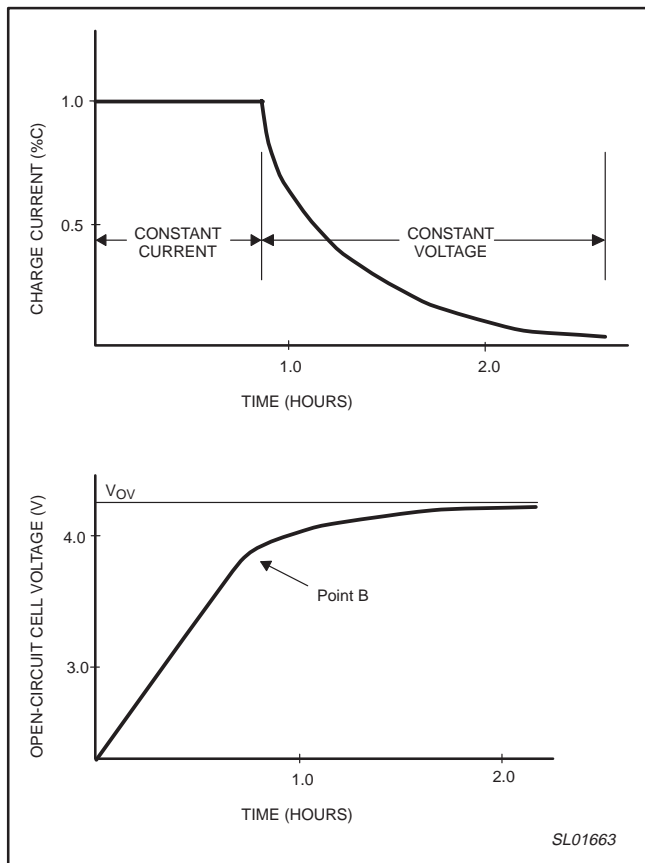

Figure 4. Lithium cell charging curves.

The charger IC begins charging with a current that is typically the rating of the cell (1C) or the milliampere rating of the cell. As the cell approaches its full-charge voltage rating (V_{OV}), the current entering the cell decreases, and the charger IC provides a constant voltage. When the charge current falls below a preset amount, 50 mA for example, the charge is discontinued.

If charging is begun below the overdischarged voltage rating of the cell, it is important to slowly raise the cell voltage up to this overdischarged voltage level. This is done by a **reconditioning charge**. A small amount of current is provided to the cell (50 mA for example), and the cell voltage is allowed a period of time to rise to the overdischarged voltage. If the cell voltage recovers, then a normal charging sequence can begin. If the cell does not reach the overdischarged voltage level, then the cell is too damaged to charge and the charge is discontinued.

To take advantage of the larger energy density of lithium cells it is important to allow enough time to completely charge the cell. When the charger switches from constant current to constant voltage charge (Point B, Figure 4) the cell only contains about 80 percent of its full capacity. When the cell is 100 mV less than its full rated charge voltage the capacity contained within the cell is 95 percent. Allowing the cell to slowly complete its charge takes advantage of the larger capacity of the lithium cells.

Single cell Li-ion battery charger

NE57611

NE57611 CHARACTERISTICS

The NE57611 is a precise linear-mode battery charger with a cell undervoltage detector. It contains the minimum circuitry needed to safely charge a lithium-ion or lithium-polymer cell. This makes it good for very compact, portable applications.

The charging process is permitted to start when the DC input voltage is greater than $V_{IN(min)}$, the battery voltage is less than the overvoltage point (V_{OV}), and the ON/OFF pin is LOW. The cell voltage is continuously monitored by the charge controller and will fall into one of three voltage ranges:

1. If the cell has been severely discharged or allowed to sit on the shelf for a long period of time, the cell will be in the undervoltage range, which is less than 2.3 V.
2. If the cell has only been partially discharged then the voltage will fall into the normal range.
3. If the cell has inadvertently been overcharged and is being reconnected to the charger, the cell is in the overcharged range.

The charger circuit then responds in the following manner if the battery pack voltage is:

1. $<2.15\text{ V}$ (V_{LV}): The \overline{LV} pin (open collector) assumes a LOW state which enables an external precharge circuit. The precharge circuit then charges the undervoltage cell with a very low current (1 – 5 mA) to bring the cell voltage up to a voltage greater than V_{LV} . This may take a long time depending upon the depth of the overdischarge.
2. $2.15\text{ V} < V_{CELL} < 4.35\text{ V}$ (V_{OV}): The normal charge current is placed into the battery pack. During this time, the charge controller charges the cell with a constant current as set by the value of R_{CS} . When the cell voltage approaches the overvoltage threshold, the charging current begins to decrease until the cell voltage reaches the overvoltage termination voltage. This portion of the charge process is called constant voltage charge.
3. $V_{CELL} > 4.35\text{ V}$ (V_{OV}): The charge current tapers down to zero and the charging is discontinued. Some small current will continue to flow into the cell to replace any self-discharge losses within the cell, but will not overcharge the cell.

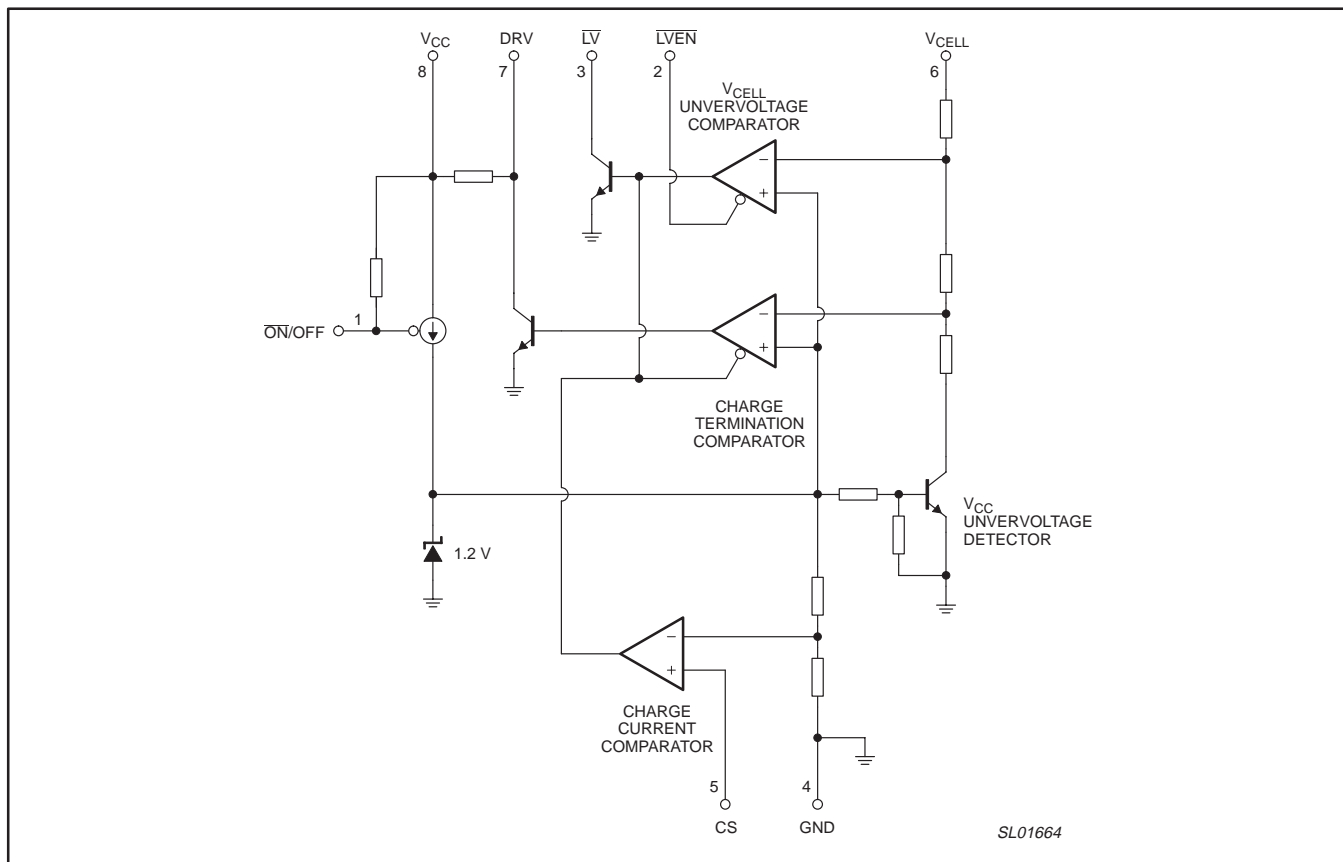

Figure 5. Functional diagram.

Single cell Li-ion battery charger

NE57611

APPLICATION INFORMATION

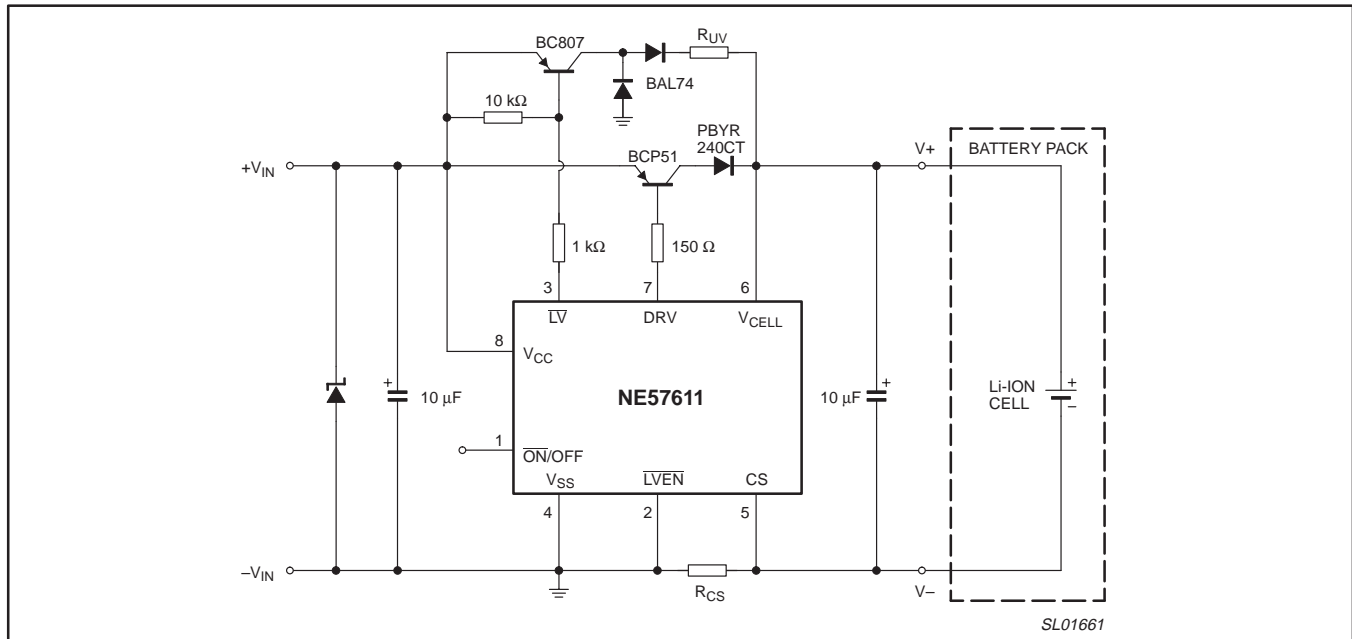

Figure 6. Typical charger circuit.

Figure 6 shows the typical implementation of a single-cell Lithium-ion battery charger using the NE57611.

Setting the reconditioning charge current

This charging current is needed when the cell voltage is less than 2.15 V. The current is limited by R_{UV} and its approximate value should be calculated by:

$$R_{UV} = [V_{in(max)} - V_{CELL(min)}] / I_{chg(recond)}$$

The reconditioning current should be 1 to 5 mA.

To set the normal maximum charging current, first determine the desired charge rate for the particular lithium cell in use within the battery pack. The cell's datasheet should provide the recommended maximum rate of charge. Charging at this rate should completely charge the cell in under 3 hours.

The value of R_{CS} that regulates the normal charging current can be found by:

$$R_{CS} = 0.1 V / I_{chg(normal)}$$

Designing the power section of the battery charger

There are several factors that are important to the design of a reliable Li-ion battery charger system. These major factors are:

1. The input voltage must not fall below the cell voltage plus the headroom voltage of the charger circuit. The headroom voltage for the charger circuit is 0.6 V, which would make the minimum input voltage about 5.0 V for a Li-ion cell rated at 4.3 V

maximum. This requirement would also include the troughs of any ripple voltage riding atop the DC input voltage from a poorly filtered wall transformer.

2. The maximum input voltage must not exceed the voltage ratings of the components in the charging circuit.
3. The power rating and the thermal design of the linear pass transistor must be able to withstand the maximum experienced headroom voltage at the rated normal charge current. The worst case condition can be calculated by assuming the cell is at its lowest voltage (typically 2.3 V) and the input voltage is at its highest point in its range (typically the DC voltage created at the highest AC input).

The power can then be calculated by:

$$P_{D(max)} = (V_{IN(max)} - V_{CELL(min)}) (I_{charge})$$

The criteria for the selection of the PNP power transistor should be:

$$\begin{aligned} V_{CEO} &> 1.5 V_{IN(max)} \\ I_c &> 1.5 I_{charge} \\ h_{FE} &> 50 @ 1 \text{ Amp} \\ P_D &> P_{D(max)} \end{aligned}$$

The choice of power package should be done with the highest possible power dissipation and at the highest expected ambient temperature. One can choose a package by referring to Figure 7 and drawing two intersecting lines from the appropriate points on the X and Y axis.

Single cell Li-ion battery charger

NE57611

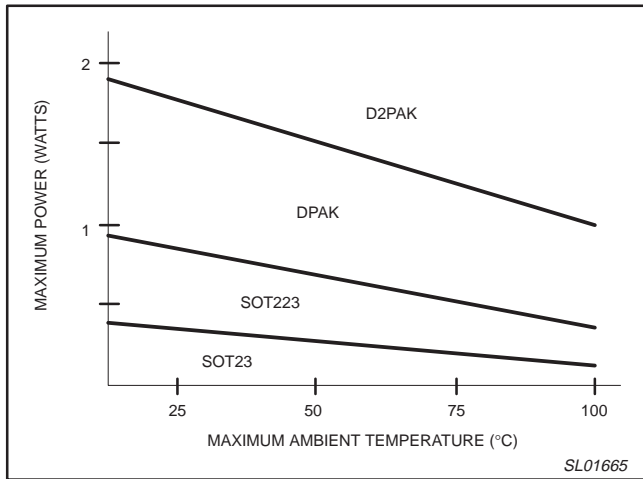

Figure 7. Pass transistor surface mount packages using the minimum recommended footprint.

This chart gives the power transistor package one can use if the minimum recommended pad size is used under the power part. If a larger copper pad is provided under the power device, the power handling capability of the part can be increased without sacrificing its reliability. Table 1 shows how to dissipate more power in a smaller part.

Table 1. Power handling capability

Given for F4 fiberglass PCB with 2 oz. copper

Pad Size	$R_{th(j-a)}$	Power increase (%)
2X	0.88 K/W	14%
3X	0.80 K/W	25%
4X	0.74 K/W	35%
5X	0.70 K/W	43%

NOTE:

Going beyond five times the minimum recommended footprint yields diminishing improvements to the thermal performance.

Placing the overvoltage thresholds

For safety and reliability, the lithium-ion protection circuit inside the battery pack should not be used to terminate the charging process routinely. The protection circuit should only activate when the charger has failed. Therefore, the full-charge termination voltage should be set lower than the overvoltage trip threshold of the protection circuit. To assure that the protection circuit never trips routinely, the charger termination voltage should be set below the sum of the two voltage accuracy tolerances of the protection circuit and the charger. This would be about 50 – 55 mV below.

Design-related safety issues

In designing charging circuits for lithium-ion and polymer cells, the designer should provide for user mishandling, common environmental hazards and for random component failures. Some of the user-related issues are plugging the battery pack into the charger backwards, live insertion of the battery into the charger and the charger into the input voltage source. A reverse biased diode is typically provided for the reversed battery. This shunts the reverse currents away from the IC thus protecting the functionality of the charger. To protect against live insertion of battery and input power source, check the sequence of how the circuit powers-up to make sure that there are no sequences that can lead to a failure or hazardous condition.

A common adverse operating condition is lightning caused transients. A 500 mW zener diode across the input terminals handles positive and negative transients caused by lightning. The zener will fail short-circuited, if the energy exceeds its surge energy ratings. To help protect the protection zener, place a small inductor or low value resistor in series from the input source. This will lower the peak voltage and energy and distribute it over a longer period.

Single cell Li-ion battery charger

NE57611

PACKING METHOD

The NE57611 is packed in reels, as shown in Figure 8.

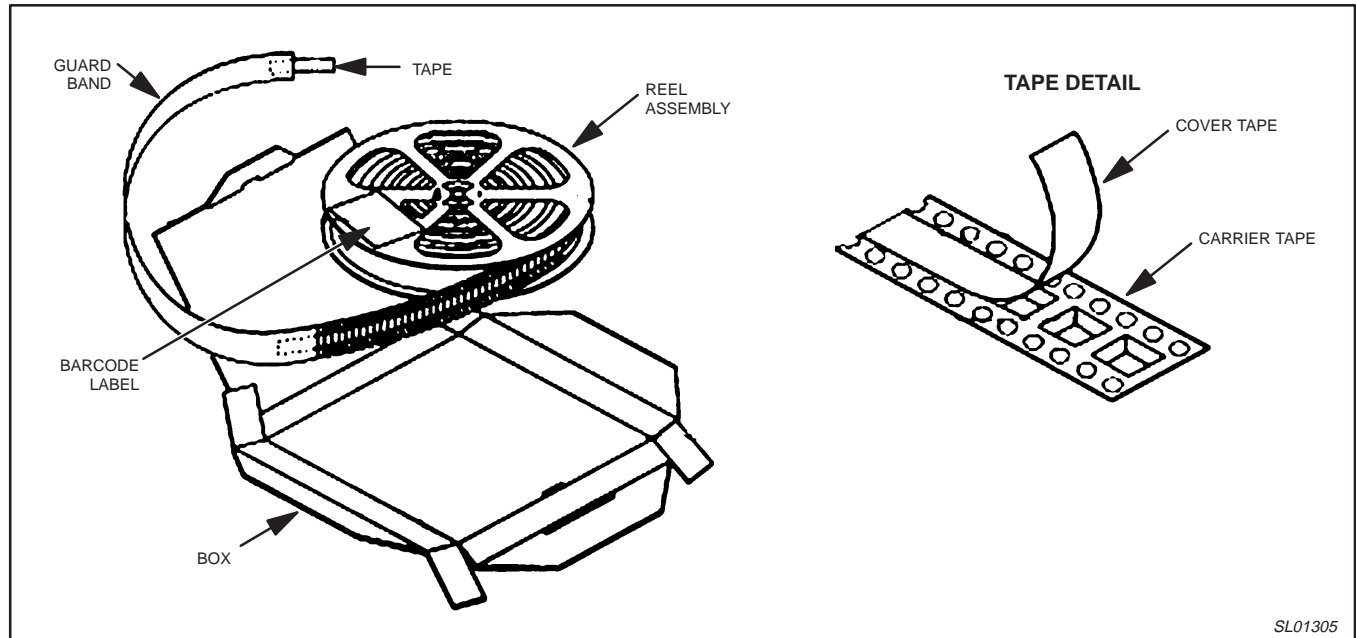
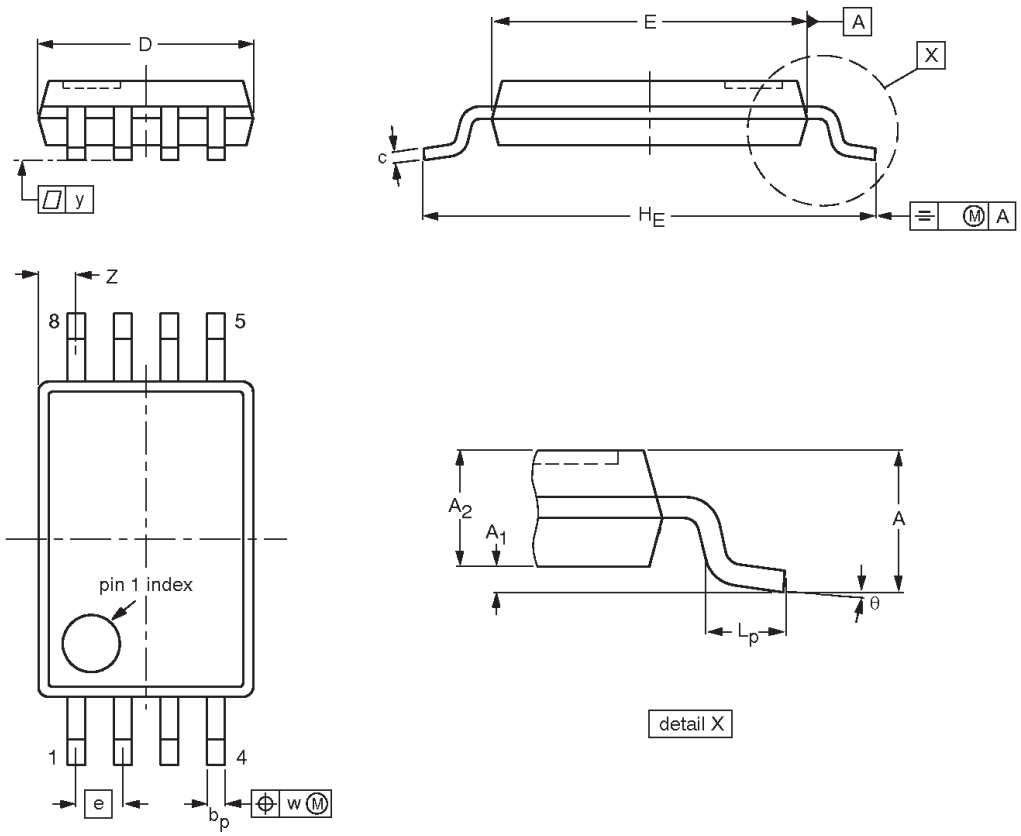

Figure 8. Tape and reel packing method.

Single cell Li-ion battery charger

NE57611

VSOP-8A: plastic small outline package; 8 leads; body width 4.4 mm



DIMENSIONS (mm are the original dimensions)

UNIT	A	A ₁	A ₂	b _p	c	D ⁽¹⁾	E ⁽²⁾	e	H _E	L _p	w	y	Z ⁽¹⁾	θ
mm	1.35 1.15	0.15 0.05	1.15	0.23 0.21	0.16 0.10	3.4 2.8	4.6 4.2	0.65	6.7 6.1	0.7 0.3	0.12	0.10	0.875 max.	10° 0°

Notes

1. Plastic or metal protrusions of 0.15 mm maximum per side are not included.
2. Plastic or metal protrusions of 0.25 mm maximum per side are not included.

OUTLINE VERSION	REFERENCES				EUROPEAN PROJECTION
	IEC	JEDEC	EIAJ		
VSOP-8A					

Single cell Li-ion battery charger

NE57611

REVISION HISTORY

Rev	Date	Description
_2	20031015	Product data (9397 750 12181). ECN 853–2330 30445 of 14 October 2003. Supersedes data of 2002 Dec 10 (9397 750 10171). Modifications: • Pin numbering corrected in Figures 1, 2, 5, and 6 and 'Pin description' table on page 3.
_1	20021210	Product data (9397 750 10171); initial version. ECN 853–2330 27919 of 25 March 2002.

Data sheet status

Level	Data sheet status ^[1]	Product status ^{[2] [3]}	Definitions
I	Objective data	Development	This data sheet contains data from the objective specification for product development. Philips Semiconductors reserves the right to change the specification in any manner without notice.
II	Preliminary data	Qualification	This data sheet contains data from the preliminary specification. Supplementary data will be published at a later date. Philips Semiconductors reserves the right to change the specification without notice, in order to improve the design and supply the best possible product.
III	Product data	Production	This data sheet contains data from the product specification. Philips Semiconductors reserves the right to make changes at any time in order to improve the design, manufacturing and supply. Relevant changes will be communicated via a Customer Product/Process Change Notification (CPCN).

[1] Please consult the most recently issued data sheet before initiating or completing a design.

[2] The product status of the device(s) described in this data sheet may have changed since this data sheet was published. The latest information is available on the Internet at URL <http://www.semiconductors.philips.com>.

[3] For data sheets describing multiple type numbers, the highest-level product status determines the data sheet status.

Definitions

Short-form specification — The data in a short-form specification is extracted from a full data sheet with the same type number and title. For detailed information see the relevant data sheet or data handbook.

Limiting values definition — Limiting values given are in accordance with the Absolute Maximum Rating System (IEC 60134). Stress above one or more of the limiting values may cause permanent damage to the device. These are stress ratings only and operation of the device at these or at any other conditions above those given in the Characteristics sections of the specification is not implied. Exposure to limiting values for extended periods may affect device reliability.

Application information — Applications that are described herein for any of these products are for illustrative purposes only. Philips Semiconductors make no representation or warranty that such applications will be suitable for the specified use without further testing or modification.

Disclaimers

Life support — These products are not designed for use in life support appliances, devices, or systems where malfunction of these products can reasonably be expected to result in personal injury. Philips Semiconductors customers using or selling these products for use in such applications do so at their own risk and agree to fully indemnify Philips Semiconductors for any damages resulting from such application.

Right to make changes — Philips Semiconductors reserves the right to make changes in the products—including circuits, standard cells, and/or software—described or contained herein in order to improve design and/or performance. When the product is in full production (status 'Production'), relevant changes will be communicated via a Customer Product/Process Change Notification (CPCN). Philips Semiconductors assumes no responsibility or liability for the use of any of these products, conveys no license or title under any patent, copyright, or mask work right to these products, and makes no representations or warranties that these products are free from patent, copyright, or mask work right infringement, unless otherwise specified.

Contact information

For additional information please visit
<http://www.semiconductors.philips.com>. Fax: +31 40 27 24825

© Koninklijke Philips Electronics N.V. 2003
All rights reserved. Printed in U.S.A.

Date of release: 10-03

For sales offices addresses send e-mail to:
sales.addresses@www.semiconductors.philips.com

Document order number:

9397 750 12181

Let's make things better.