



Description

The MK3713 is ICS/MicroClock's lowest cost, low jitter, high performance 3.3 Volt VCXO designed to replace expensive VCXO modules. The on-chip Voltage Controlled Crystal Oscillator accepts a 0 to 3.3 V input voltage to cause the output clocks to vary by ± 100 ppm. Using ICS/MicroClock's patented VCXO and analog Phase-Locked Loop (PLL) techniques, the device uses an inexpensive external pullable crystal input to produce the output clock.

ICS/MicroClock manufactures the largest variety of communications, set-top box, and multimedia clock synthesizers for all applications. If more clock outputs are needed, see the MK3732 or MK377x family of parts. Consult ICS/MicroClock to eliminate VCXOs, crystals and oscillators from your board.

Features

- Packaged in 8 pin SOIC 
- Ideal for T1 and E1 VCXOs
- Output range of 1.25 MHz to 10 MHz
- For a 10-20 MHz output range, use the MK3711
- For higher than 20 MHz, use the MK3732-05
- 3.3 V only operating voltage
- Uses an inexpensive 10 - 20 MHz external crystal
- On-chip VCXO (patented) with pull range of 200ppm (minimum)
- VCXO tuning voltage of 0 to 3.3 V
- 12mA output drive capability at TTL levels
- Advanced, low power, sub-micron CMOS process

Block Diagram

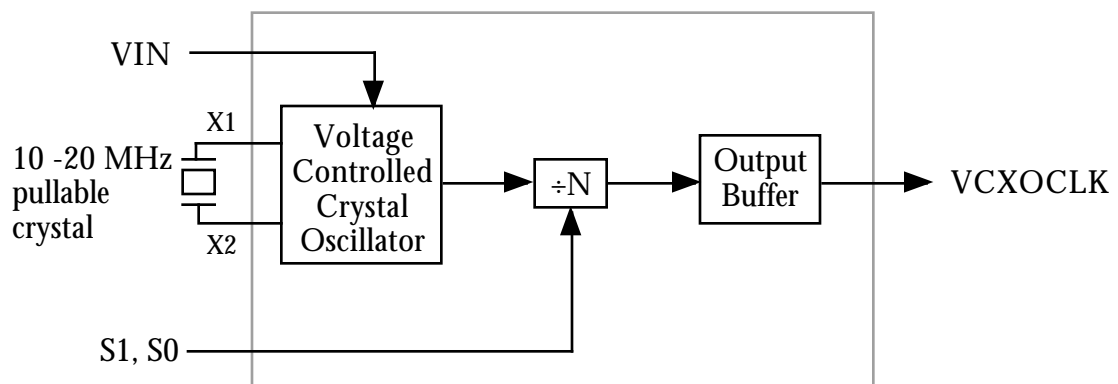

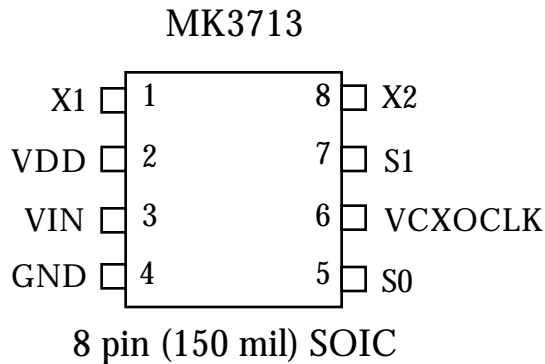
**Pin Assignment****Divider Select Table**

S1	S0	VCXOCLK (MHz)
0	0	Crystal ÷2
0	1	Crystal ÷4
1	0	Crystal ÷6
1	1	Crystal ÷8

Application Tip

For 1.544 MHz (T1), use 12.352 MHz crystal ÷8
 For 2.048 MHz (E1), use 12.288 MHz crystal ÷6

Pin Descriptions

Number	Name	Description
1	X1	Crystal connection. Connect to a pullable 10 to 20 MHz crystal.
2	VDD	VDD. Connect to + 3.3 V.
3	VIN	Voltage input to VCXO. Zero to 3.3 V analog input which controls the frequency of the VCXO.
4	GND	Connect to ground.
5	S0	Select pin for VCXO divider. See table above.
6	VCXOCLK	VCXO clock output. Full CMOS output amplitude.
7	S1	Select pin for VCXO divider. See table above.
8	X2	Crystal connection. Connect to a pullable 10 to 20 MHz crystal.

Pullable Crystal Specifications:

Correlation (load) Capacitance	14 pF
C0/C1	240 max
ESR	35 max
Operating Temperature	0 to 70 °C
Initial Accuracy	±20 ppm
Temperature plus Aging Stability	±50 ppm



Electrical Specifications

Parameter	Conditions	Minimum	Typical	Maximum	Units
ABSOLUTE MAXIMUM RATINGS (note 1)					
Supply voltage, VDD	Referenced to GND			7	V
Inputs and Clock Outputs	Referenced to GND	-0.5		VDD+0.5	V
Ambient Operating Temperature		0		70	°C
Soldering Temperature	Max of 10 seconds			260	°C
Storage temperature		-65		150	°C
DC CHARACTERISTICS (VDD = 3.3 V unless noted)					
Operating Voltage, VDD		3.15	3.30	3.45	V
Output High Voltage, VOH	IOH=-12mA	2.4			V
Output Low Voltage, VOL	IOL=12mA			0.4	V
Output High Voltage, VOH, CMOS level	IOH=-4mA	VDD-0.4			V
Input High Voltage, VIH		2			V
Input Low Voltage, VIL				0.8	V
Operating Supply Current, IDD	No Load		7		mA
Short Circuit Current			±50		mA
VIN, VCXO control voltage		0		3.3	V
AC CHARACTERISTICS (VDD = 3.3 V unless noted)					
Input Crystal Frequency		10		20	MHz
Input Crystal Accuracy				±30	ppm
Output Clock Rise Time	0.8 to 2.0V			1.5	ns
Output Clock Fall Time	2.0 to 0.8V			1.5	ns
Output Clock Duty Cycle	At VDD/2	40	50	60	%
Output Clock Pullability, note 2	0V VIN 3.3 V	±100			ppm

- Notes: 1. Stresses beyond those listed under Absolute Maximum Ratings could cause permanent damage to the device. Prolonged exposure to levels above the operating limits but below the Absolute Maximums may affect device reliability.
2. With a ICS/MicroClock approved pullable crystal.

External Components

The MK3713 requires a minimum number of external components for proper operation. A decoupling capacitor of 0.01µF should be connected between VDD and GND on pins 2 and 4, as close to the MK3713 as possible. A series termination resistor of 33 Ω may be used for the clock output. The input crystal must be connected as close to the chip as possible. The input crystal should be a parallel mode, pullable, AT cut, 13.5 MHz, with 14 pF load capacitance. Consult ICS for recommended suppliers. **IMPORTANT** - read application note MAN05 before laying out the PCB.



Package Outline and Package Dimensions

(For current dimensional specifications, see JEDEC Publication No. 95.)

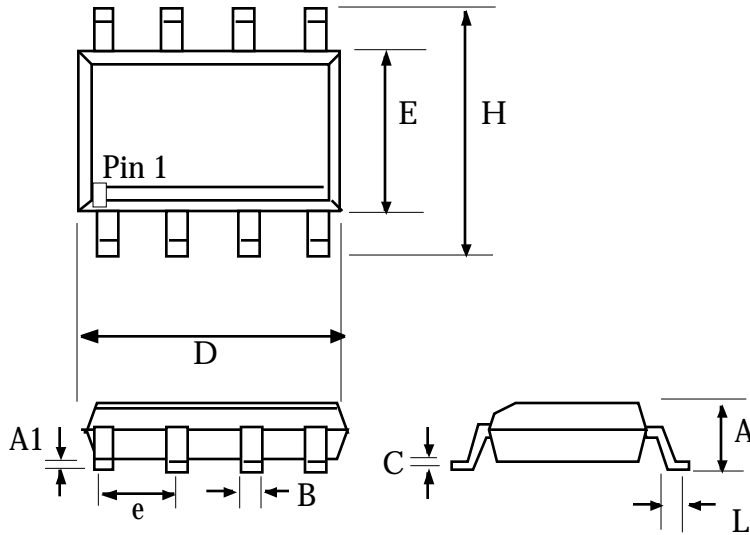

8 pin SOIC

Symbol	Inches		Millimeters	
	Min	Max	Min	Max
A	0.0532	0.0688	1.35	1.75
A1	0.0040	0.0098	0.10	0.24
B	0.0130	0.0200	0.33	0.51
C	0.0075	0.0098	0.19	0.24
D	0.1890	0.1968	4.80	5.00
E	0.1497	0.1574	3.80	4.00
e	.050 BSC		1.27 BSC	
H	0.2284	0.2440	5.80	6.20
h	0.0099	0.0195	0.25	0.50
L	0.0160	0.0500	0.41	1.27

Ordering Information

Part/Order Number	Marking	Shipping packaging	Package	Temperature
MK3713S	MK3713S	tubes	8 pin SOIC	0-70 °C
MK3713STR	MK3713S	tape and reel	8 pin SOIC	0-70 °C

CHANGE HISTORY

Version	Date first published	Status	Comments
B	2/09/00	Preliminary	Changed max output frequency to 10 MHz
A	12/29/99	Preliminary	Original

While the information presented herein has been checked for both accuracy and reliability, Integrated Circuit Systems Incorporated (ICS) assumes no responsibility for either its use or for the infringement of any patents or other rights of third parties, which would result from its use. No other circuits, patents, or licenses are implied. This product is intended for use in normal commercial applications. Any other applications such as those requiring extended temperature range, high reliability, or other extraordinary environmental requirements are not recommended without additional processing by ICS. ICS reserves the right to change any circuitry or specifications without notice. ICS does not authorize or warrant any ICS product for use in life support devices or critical medical instruments.