

DUAL TONE MULTI-FREQUENCY OSCILLATOR

MB4507A

January 1988
Edition 2.0

DUAL TONE MULTI-FREQUENCY OSCILLATOR

The Fujitsu MB4507A is a Dual Tone Multi-Frequency (DTMF) oscillator designed for use with pushbutton telephones. Depending on which pushbuttons are pressed, the MB4507A divides the output of an external crystal oscillator to generate a precise series of synthesized sine waves from an on-chip ROM and digital-to-analog converter. A 3-pole filter with external capacitors is used to provide output sine waves that are nearly distortion-free. By using an external crystal oscillator, the MB4507A can generate very stable frequencies even with an unregulated supply voltage. An inexpensive TV-color crystal (3.58 MHz) can be used for the external oscillator.

The MB4507A DTMF oscillator is housed in a 22-pin plastic DIP.

- On-chip frequency synthesizer with extremely stable output
- Sine wave outputs that are nearly distortion-free
- Inexpensive color-TV crystal (3.579545 MHz) can be used for external oscillator
- On-chip automatic pad circuit uses line-current detection with external resistor
- On-chip switch debounce circuits
- Precision tracking of key inputs permits wide tuning range of input codes
- Logic circuits decode simultaneous input of two keys:
 - Only lower group oscillates when laterally adjacent buttons are pushed simultaneously
 - Only higher group oscillates when vertically adjacent buttons are pushed simultaneously
 - No oscillation when diagonally adjacent buttons are pushed simultaneously

ABSOLUTE MAXIMUM RATINGS ($T_A = 25^\circ\text{C}$, see NOTE)

Parameter	Symbol	Value	Unit
Supply Voltage	V_L	+20	V
Supply Current	I_L	+110	mA
Input Voltage	V_{L1} to V_{L4}	+7	V
Input Current	I_{H1} to I_{H4}	0.5	mA
Operating Ambient Temperature	T_A	-35 to +65	$^\circ\text{C}$
Storage Temperature	T_{STG}	-55 to +125	$^\circ\text{C}$

NOTE: Permanent device damage may occur if the above Absolute Maximum Ratings are exceeded. Functional operation should be restricted to the conditions as detailed in the operational sections of this data sheet. Exposure to absolute maximum rating conditions for extended periods may affect device reliability.

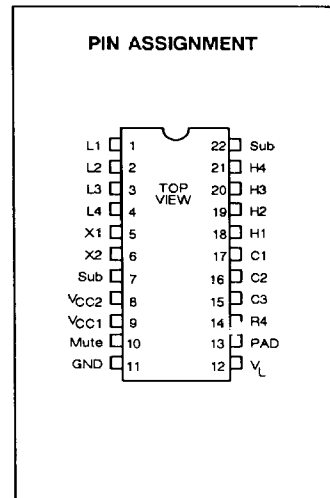
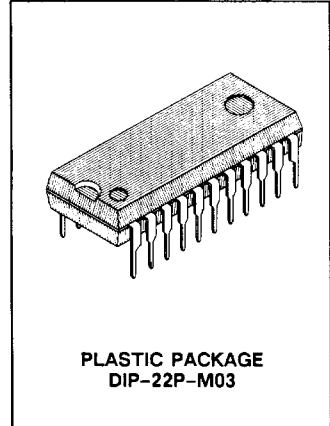

This device contains circuitry to protect the inputs against damage due to high static voltages or electric fields. However, it is advised that normal precautions be taken to avoid application of any voltage higher than maximum rated voltages to this high impedance circuit.

Fig. 1 — MB4507A BLOCK DIAGRAM

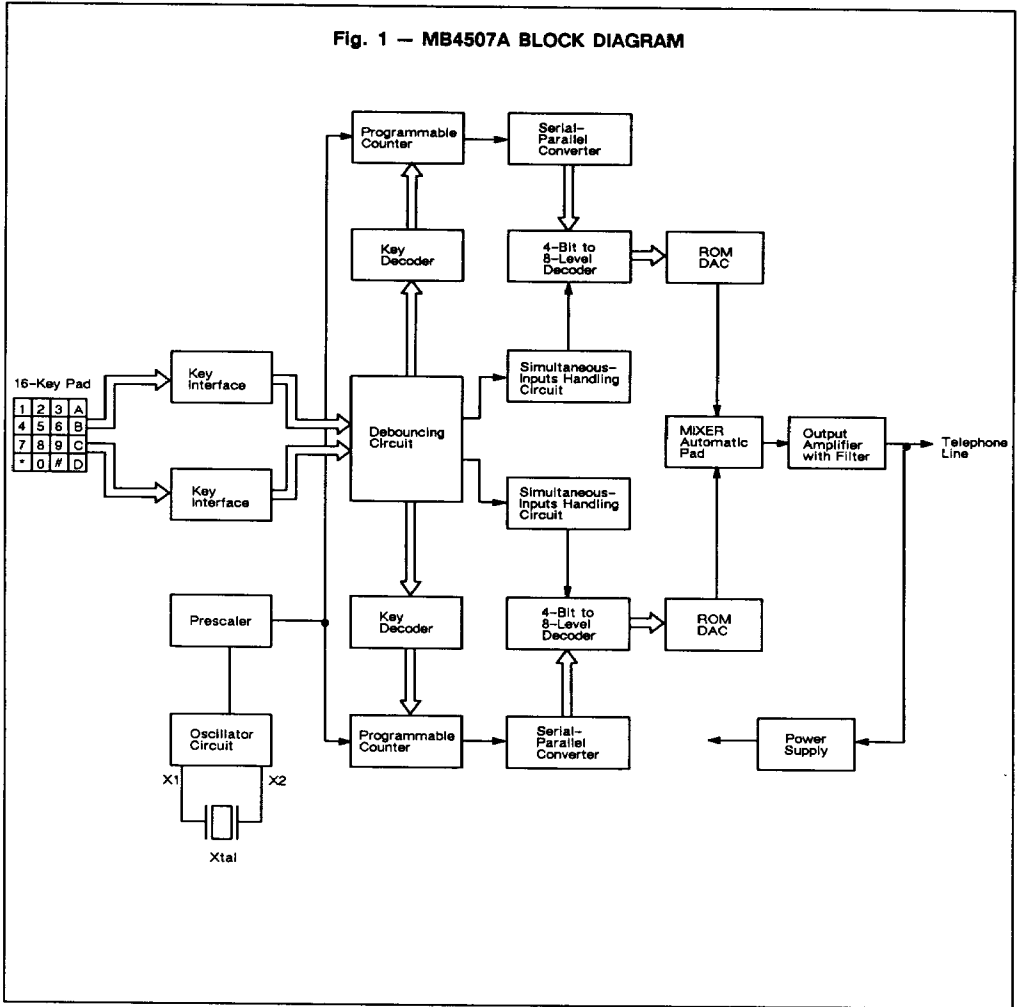

6

RECOMMENDED OPERATING CONDITIONS

(Referenced to GND)

Parameter	Symbol	Value	Unit
Supply Current	I_L	+20 to +105	mA
Crystal Frequency	f_o	3.579545	MHz
Input Voltage (L_1 to L_4)	V_{IH}	≥ 3	V
	V_{IL}	0.5 to 1.0	V
Input Current (H_1 to H_4)	I_{IH}	50 to 200	μ A
	I_{IL}	≤ 5	μ A
Ambient Temperature	T_A	-30 to +60	$^{\circ}$ C

ELECTRICAL CHARACTERISTICS

($I_L = 20$ to 70mA, $T_A = 25^{\circ}\text{C} \pm 2^{\circ}\text{C}$)

Parameter	Conditions	Symbol	Values			Unit
			Min	Typ	Max	
Frequency Deviation	$I_L = 20\text{mA}$	f_{L1}	-0.9	-0.32	+0.9	%
		f_{L2}	-0.9	+0.02	+0.9	%
		f_{L3}	-0.9	+0.03	+0.9	%
		f_{L4}	-0.9	-0.11	+0.9	%
		f_{H1}	-0.9	-0.24	+0.9	%
		f_{H2}	-0.9	-0.32	+0.9	%
		f_{H3}	-0.9	+0.64	+0.9	%
		f_{H4}	-0.9	+0.37	+0.9	%
Output Frequency		f_{L1}		695		Hz
		f_{L2}		770		Hz
		f_{L3}		852		Hz
		f_{L4}		940		Hz
		f_{H1}		1206		Hz
		f_{H2}		1332		Hz
		f_{H3}		1487		Hz
		f_{H4}		1639		Hz

ELECTRICAL CHARACTERISTICS (Continued)

(Recommended operating conditions unless otherwise noted, $T_A = 25^\circ\text{C}$)

Parameter	Conditions	Symbol	Values			Unit
			Min	Typ	Max	
Output Level	$I_L = 70\text{mA}$, button 8	V_{L3}	-11.7	-10	-8.3	dBm
		V_{H2}	-10.7	-9	-7.3	dBm
Total Harmonic Distortion	$I_L = 28\text{mA}$, L3, H2	THD	26	30		dB
ON Threshold Current	when no signal	I_{ON}		55	60	mA
OFF Threshold Current		I_{OFF}	28	35		mA
Attenuation	$I_L = 28\text{mA}/I_L = 70\text{mA}$	Loss	1.5	2.5	3.5	dB
Supply Voltage	$I_L = 20\text{mA}$	V_L		7.8	8.5	V

Fig. 2 — MEASUREMENT CIRCUIT

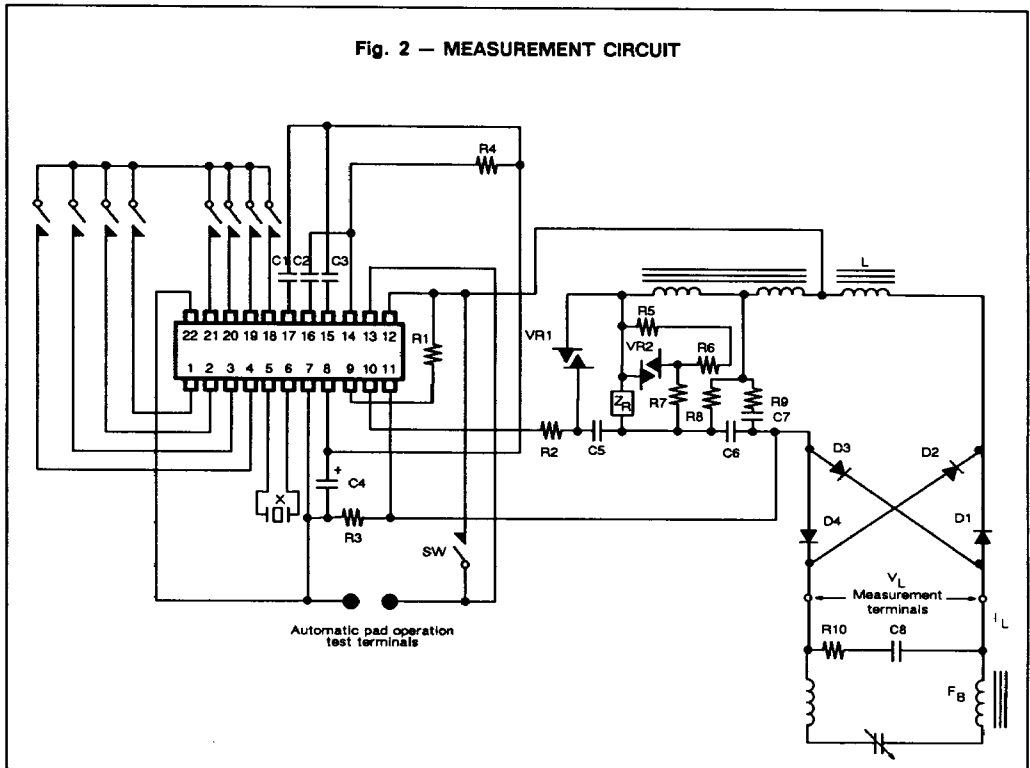

MEASUREMENT CIRCUIT PARTS LIST

Symbol	Value	Symbol	Value
X	3.579545 MHz	R8	130 OHMS
D1 to D4	SD-60P equiv.	R9	20 OHMS
VR1 to VR2	VR-60 equiv.	R10	600 OHMS
L	L62 equiv.	C1	0.015 μ F
Z _R	NTT R62 standard reference impedance	C2	0.022 μ F
R1	510 OHMS	C3	1500 pF
R2	100 OHMS	C4	0.33 μ F
R3	11 OHMS	C5	4.7 μ F
R4	30 OHMS	C6	2 μ F
R5	560 OHMS	C7	1.1 μ F
R6	620 OHMS	C8	1 μ F
R7	160 OHMS	FB	WJ-139 equiv.

DTMF OPERATION

The DTMF is designed to allow input control (key input) from either push buttons (telephone keypad) or microcomputer logic signals.

- Subscriber's line isolated from the control system.

Fig. 3 — UTILIZING PHOTOISOLATION TECHNIQUES

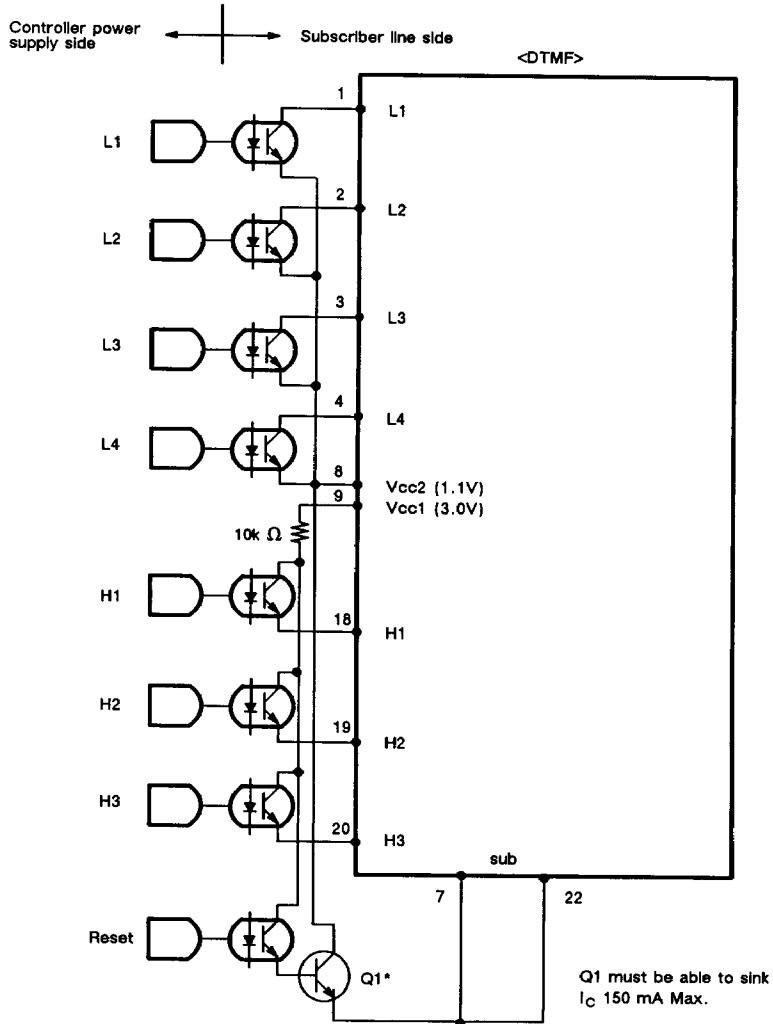
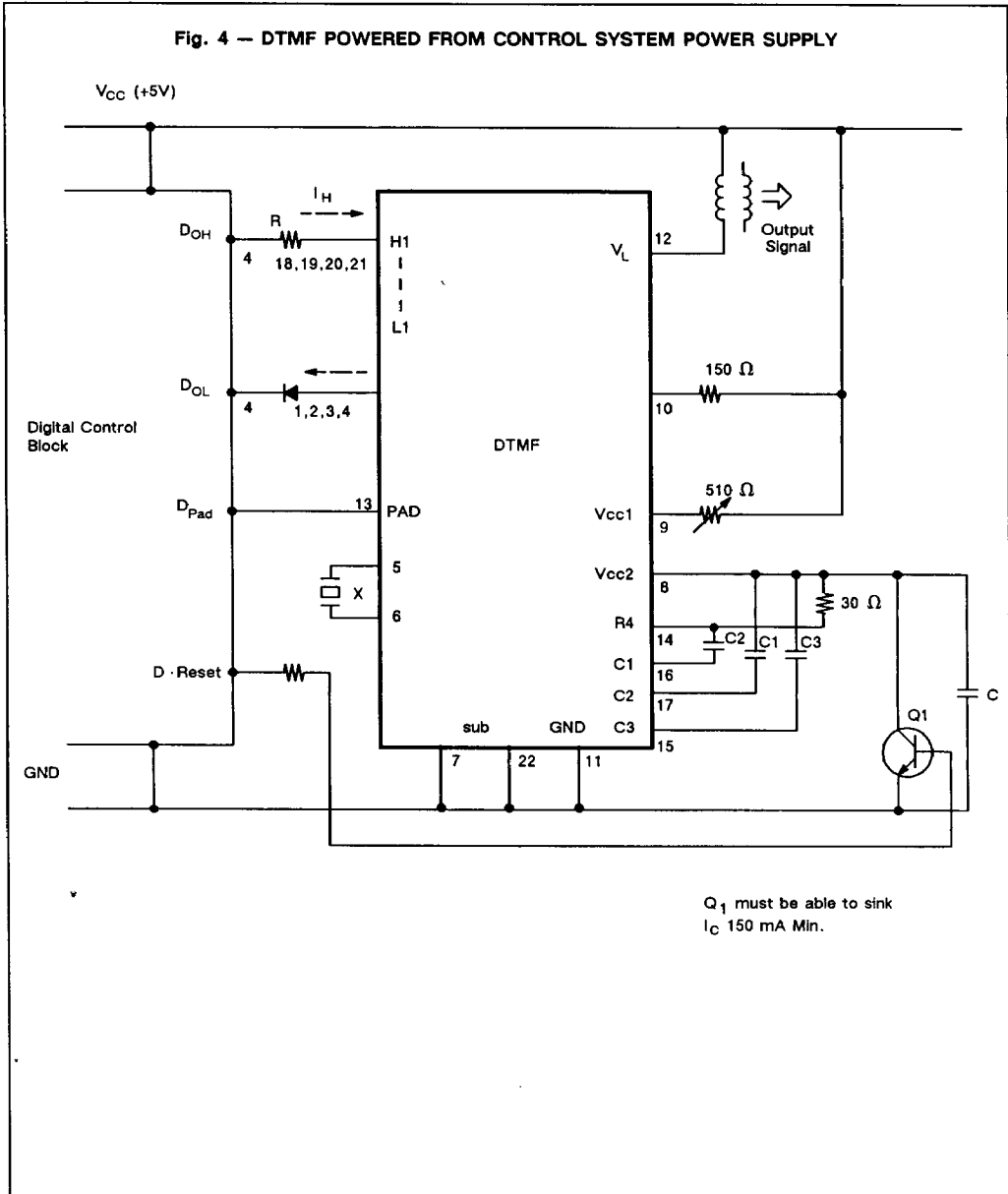

Fig. 4 — DTMF POWERED FROM CONTROL SYSTEM POWER SUPPLY



EXAMPLE USING EXTERNAL CLOCK SIGNAL

An external 3.58 MHz clock signal may be applied to Input X1. However, care must be taken to properly isolate the external

clock to prevent coupling to the on-chip bias levels of the DTMF IC. Three methods are shown below to accomplish this.

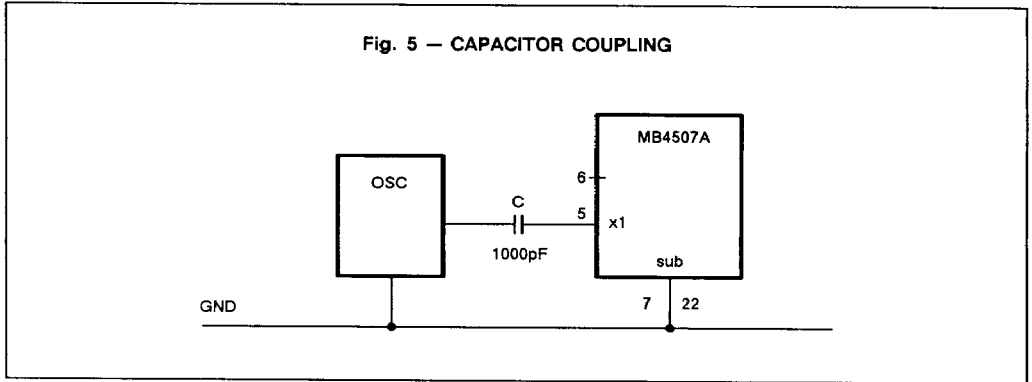

6

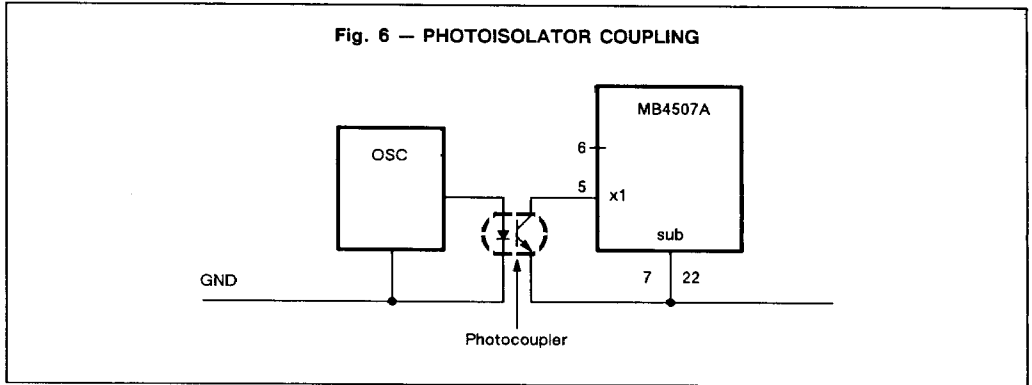

Fig. 7 — TRANSFORMER COUPLING

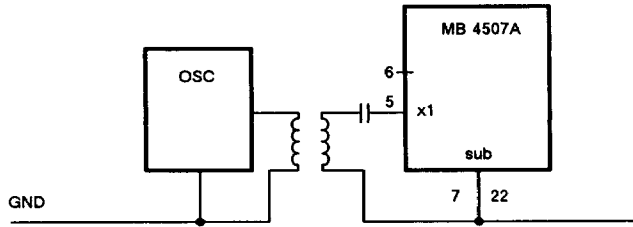
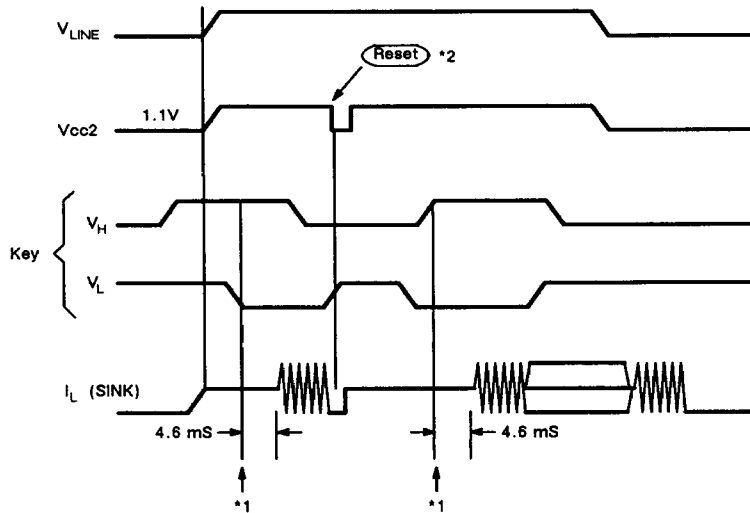

Fig. 8 — TIMING DIAGRAM



Notes:

- *1. V_H H
- V_L L
- V_{LINE} ...Power -on
($V_{CC2}=1.1V$)

} Calling starts after 4.6mS. During this 4.6mS interval, the previous conditions must be maintained.

- *2. The DTMF can be reset by externally shorting V_{CC2} to GND.

Fig. 9 — MB 4507A DTMF EQUIVALENT CIRCUIT INPUT-OUTPUT BLOCKS

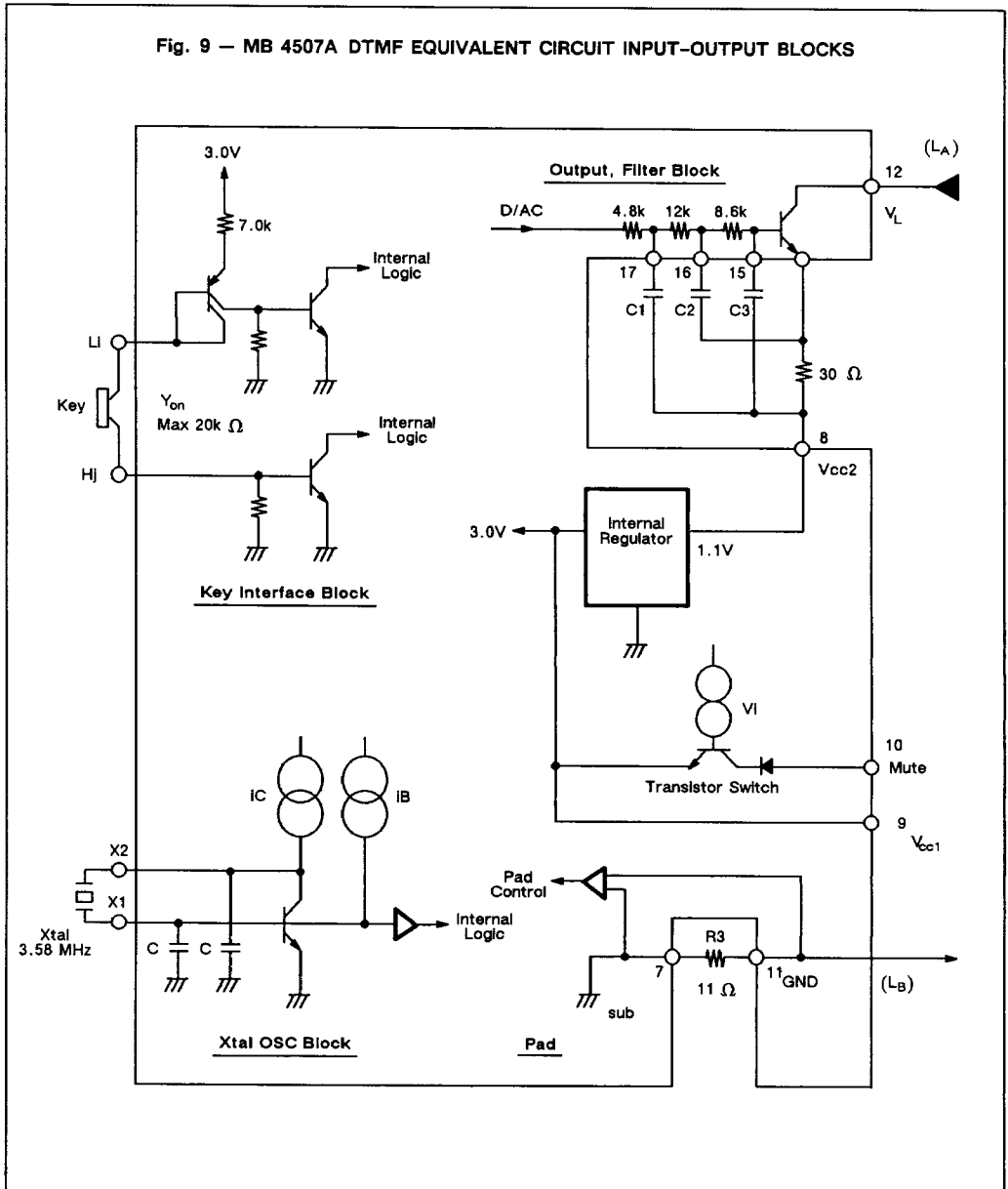

6

PACKAGE DIMENSIONS

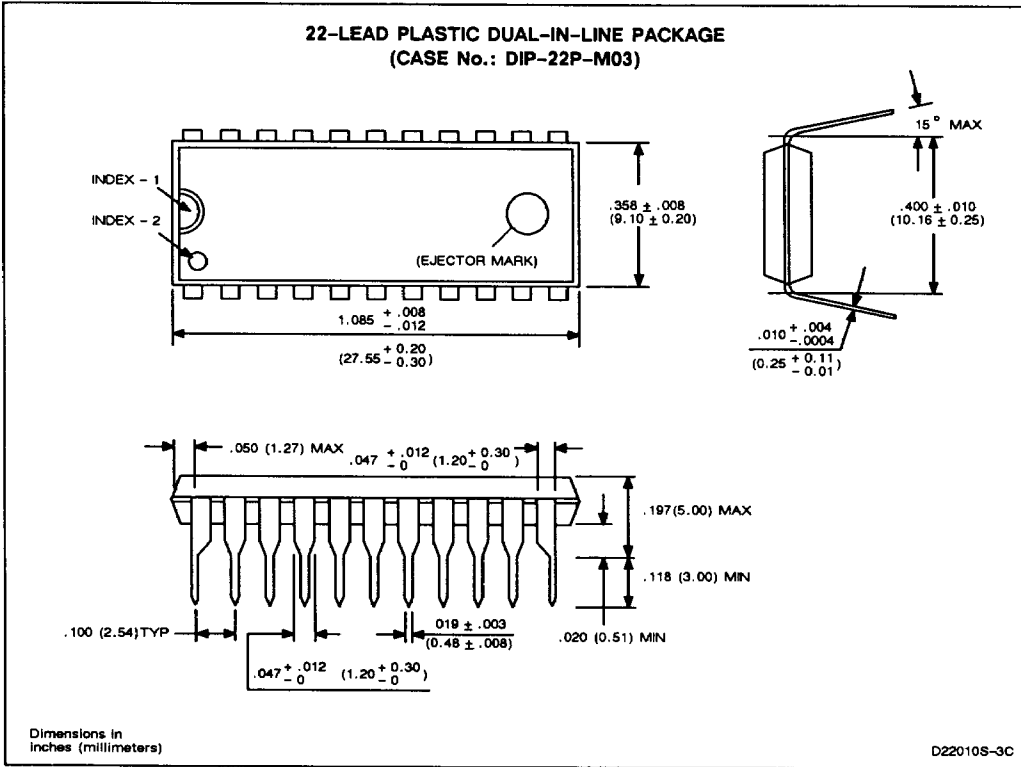

6