

# KSM-100 LM2T

The KSM-100 LM2T consist of a PIN Photodiode of high speed and a preamplifier IC in the package as an receiver for Infrared remote control systems

### Features

- One mold large size package
- Supply-voltage range : 4.5V to 5.5V
- Shielded against electrical field disturbance
- High immunity against ambient light disturbances (Logic Controller Adaptation)
- Available for carrier frequencies between 32.7KHz to 56.9KHz
- TTL and CMOS compatible

### Applications

- Audio & Video Applications (TV, VTR, Audio, DVDP, CDP)
- Home Appliances (Air conditioner, Computer, Camcorder)
- Wireless Toys
- Remote Control Equipment

### DIMENSIONS

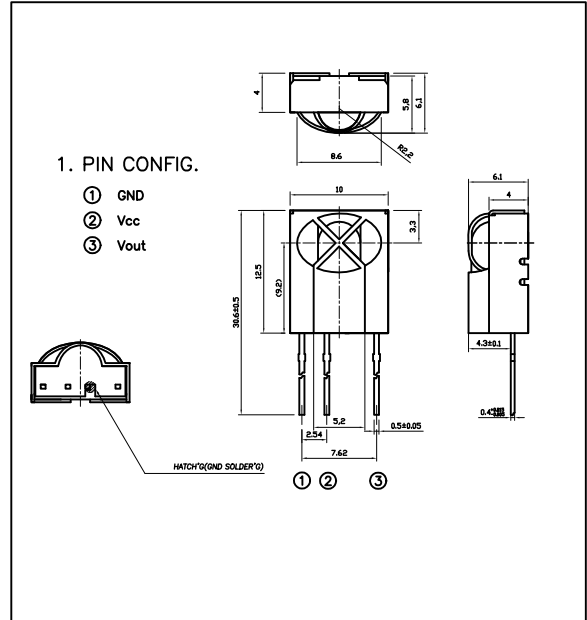

### Maximum Ratings

[Ta=25 ]

Parameter	Symbol	Ratings	Unit
Supply Voltage	Vcc	6.0	V
Operating Temperature	Topr	-10 ~ +60	
Storage Temperature	Tstg	-20 ~ +75	
Soldering Temperature	Tsol	260 (Max 5 sec)	

### B.P.F Center Frequency

Model No.	B.P.F Center Frequency(kHz)
KSM-1001LM2T	40.0
KSM-1002LM2T	36.7
KSM-1003LM2T	37.9
KSM-1004LM2T	32.7
KSM-1005LM2T	56.9

### Electro-Optical Characteristics

[Ta=25 , Vcc=5.0V]

Parameter	Symbol	Condition	Min.	Typ.	Max.	Unit	
Recommended Supply Voltage	Vcc		4.5	5	5.5	V	
Current Consumption	Icc	No signal input	-	1.0	1.2	mA	
Peak Wavelength *1	$\lambda$		-	940	-	nm	
B.P.F Center Frequency	fo		-	37.9	-	kHz	
Transmission Distance *1	L	250 ± 50lx	0 °	15	-	-	m
			± 30 °	12	-	-	
High level Output voltage *1	V <sub>OH</sub>	30cm over the ray axis	4.5	5.0	-	V	
Low level Output voltage *1	V <sub>OL</sub>		-	0.1	0.25	V	
High level Output Pulse Width *1	T <sub>WH</sub>	Burst wave=600 $\mu$ s	400	600	700	$\mu$ s	
Low level Output Pulse Width *1	T <sub>WL</sub>	Period = 1.2ms	500	600	800	$\mu$ s	
Output Form	Active Low Output						

\*1. It specifies the maximum distance between emitter and detector that the output wave form satisfies the standard under the conditions below against the standard transmitter.

- 1) Measuring place : Indoor without extreme reflection of light
- 2) Ambient light source : Detecting surface illumination shall be irradiate 200 ± 50lx under ordinary white fluorescence lamp without high frequency lightning
- 3) Standard transmitter : Burst wave of standard transmitter shall be arranged to 50mVP-P under the measuring circuit

# KSM-100 □ LM2T

## Measuring Method [Ta=25°C]

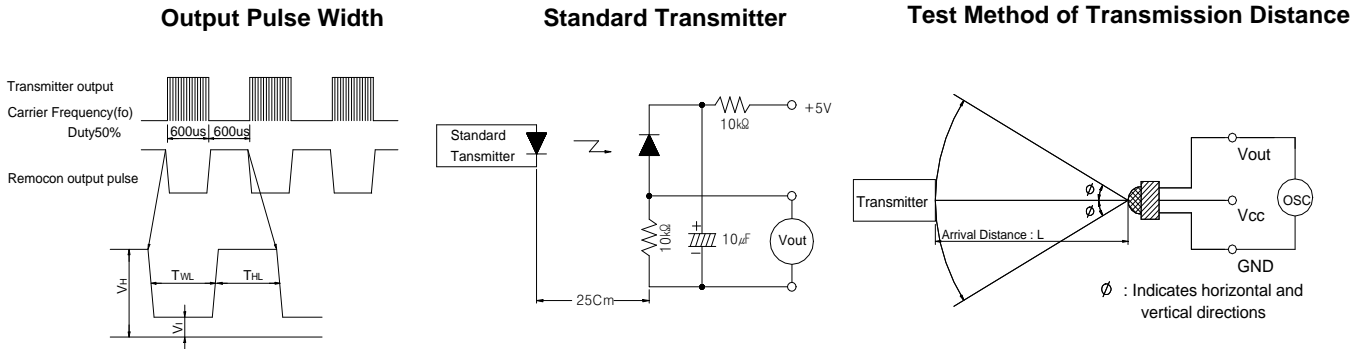

## Typical Characteristics Curve [Ta=25°C]

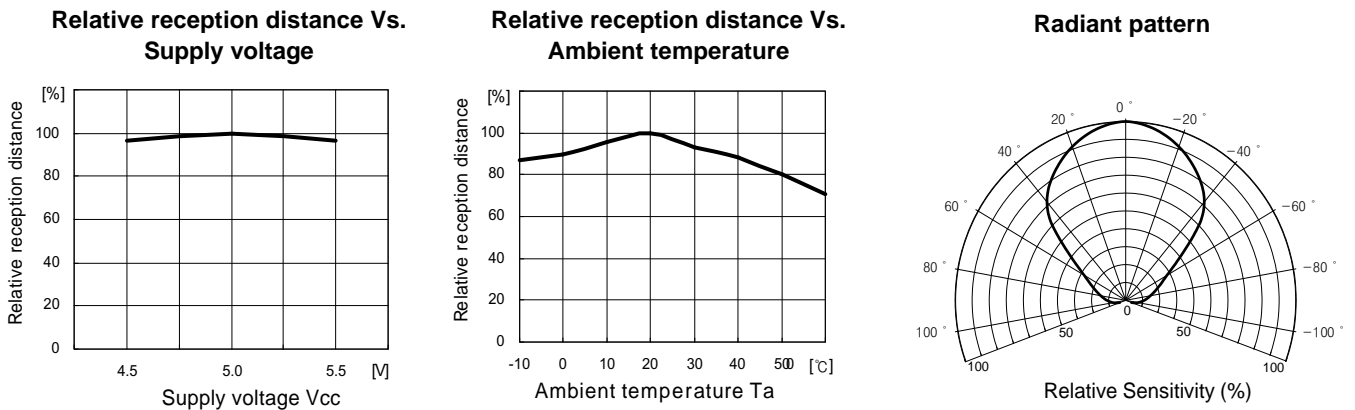

## Standard Application Circuit with R-C Decoupling Filter

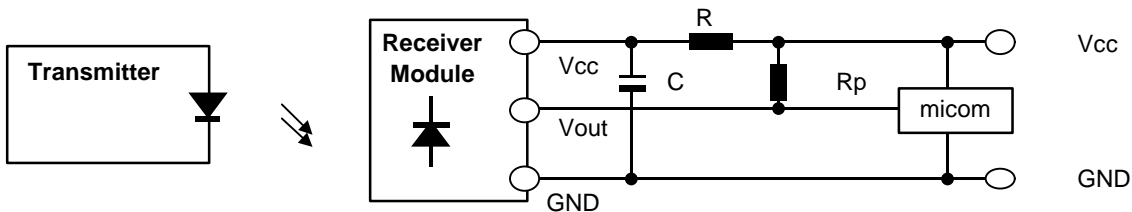

### \*1 Recommended Circuit Description

- 1) Transmitter(IRED) drive current  
:  $I_{FP} = 300mA_{P-P} \sim 600mA_{P-P}$
- 2) R-C Decoupling Filter with Lower Cut-off Frequency  
:  $R=100\Omega$  ,  $C=47\mu F \Rightarrow f_c = 1/2 \pi RC = 33.9Hz$
- 3) External pull-up resistor(optional)  
:  $10k\Omega$  over