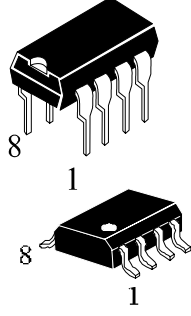


**IL2410**

**Tone Ringer**

The IL2410 is a bipolar integrated circuit designed for telephone bell replacement.

- Designed for Telephone Bell Replacement
- Low Current Drain
- Adjustable 2-frequency Tone
- Adjustable Warbling Rate
- Extension Tone Ringer Modules
- Alarms or Other Alerting Devices
- External Triggering or Ringer Disable
- Built-in hysteresis prevents false triggering and rotary dial 'Chirps'



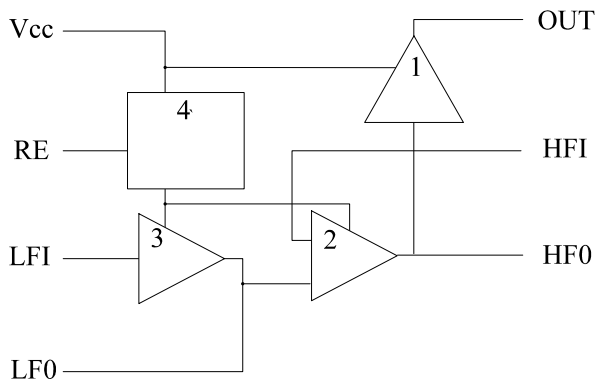
**N SUFFIX PLASTIC**

**D SUFFIX SOIC**

**ORDERING INFORMATION**

IL2410N Plastic  
 IL2410D SOIC  
 $T_A = -45^\circ$  to  $65^\circ$  C  
 for package

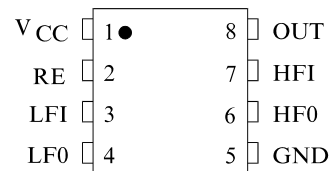
**LOGIC DIAGRAM**



PIN 1 =  $V_{CC}$   
 PIN 5 = GND

1. Output amplifier
2. High frequency oscillator
3. Low frequency oscillator
4. Hysteresis regulator  
 (Regulator circuit has built-in hysteresis to prevent false triggering and rotary dial "Chirps")

**PIN ASSIGNMENT**



**PIN DESCRIPTION**

NAME	PIN	DESCRIPTION
V <sub>CC</sub>	1	Positive power supply.
RE	2	Initiation of oscillation start input
LFI	3	Low frequency oscillator input
LF0	4	Low frequency oscillator output
GND	5	Negative power supply
HF0	6	High frequency oscillator output
HFI	7	High frequency oscillator input
OUT	8	Tone output

**MAXIMUM RATINGS\***

Symbol	Parameter	Value	Unit
V <sub>CC</sub>	DC Supply Voltage (Referenced to GND)	to +30.0	V
P <sub>D</sub>	Power Dissipation in Still Air, Plastic DIP	400	mW
T <sub>stg</sub>	Storage Temperature	-65 to +150	°C

\* Maximum Ratings are those values beyond which damage to the device may occur. Functional operation should be restricted to the Recommended Operating Conditions.

**RECOMMENDED OPERATING CONDITIONS**

Symbol	Parameter	Min	Max	Unit
V <sub>CC</sub>	DC Supply Voltage (Referenced to GND)	13.0	29.0	V
T <sub>A</sub>	Operating Temperature	-45	+65	°C

This device contains protection circuitry to guard against damage due to high static voltages or electric fields. However, precautions must be taken to avoid applications of any voltage higher than maximum rated voltages to this high-impedance circuit. For proper operation, V<sub>IN</sub> and V<sub>OUT</sub> should be constrained to the range GND ≤ (V<sub>IN</sub> or V<sub>OUT</sub>) ≤ V<sub>CC</sub>.

Unused inputs must always be tied to an appropriate logic voltage level (e.g., either GND or V<sub>CC</sub>). Unused outputs must be left open.

**ELECTRICAL CHARACTERISTICS** (Voltages Referenced to GND,  $T_A = -45$  to  $+65^\circ\text{C}$ )

Symbol	Parameter	Test Conditions	Guaranteed Limits			Unit
			Min	Typ	Max	
$V_{SI}$	Initiation Supply Voltage (1)	See Fig. 1	16.8		21.2	V
$I_{SI}$	Initiation Supply Current (1)		1.4		4.2	mA
$V_{SUS}$	Sustaining Voltage (2)	See Fig. 1	9.5		12.2	V
$I_{SUS}$	Sustaining Current (2)	No Load $V_{CC}=V_{SUS}$ See Fig. 1	0.7		2.5	mA
$V_{TR}$	Trigger Voltage (3)	$V_{CC}=15\text{V}$	8.8		12.2	V
$I_{TR}$	Trigger Current (3,5)	$V_{CC}=15\text{V}$	5.0		1000	$\mu\text{A}$
$V_{DIS}$	Disable Voltage (4)	$V_{CC}=21\text{V}$	-		0.7	V
$I_{DIS}$	Disable Current (4)	$V_{CC}=15\text{V}$	-20		-	$\mu\text{A}$
$V_{OH}$	High-Level Output Voltage	$V_{CC}=21\text{V}$ , $I_{OH}=-15\text{mA}$ , Pin 6=6V, Pin 7=GND	16.7		21.0	V
$V_{OL}$	Low-Level Output Voltage	$V_{CC}=21\text{V}$ , $I_{OL}=15\text{mA}$ , Pin 6=GND, Pin 7=6V	-		1.8	V
$I_{IN}$	Maximun Input Leakage Current (Pin 3) (Pin 7)	Pin 3=6V, Pin 4=GND, $V_{CC}=21\text{V}$	-		1.0	$\mu\text{A}$
		Pin 7=6V, Pin 6=GND, $V_{CC}=21\text{V}$	-		1.0	$\mu\text{A}$
$f_{H1}$	High Frequency 1	$R_3=191\text{K}\Omega$ , $C_3=6800\text{pF}$	461		563	Hz
$f_{H2}$	High Frequency 2	$R_3=191\text{K}\Omega$ , $C_3=6800\text{pF}$	576		704	Hz
$f_L$	Low Frequency	$R_2=165\text{K}\Omega$ , $C_2=0.47\mu\text{F}$	9.0		11.0	Hz

**Notes:**

1. Initiation supply voltage ( $V_{SI}$ ) is the supply voltage required to start the tone ringer oscillating.
2. Sustaining voltage ( $V_{SUS}$ ) is the supply voltage required to maintain oscillation.
3.  $V_{TR}$  and  $I_{TR}$  are the conditions applied to trigger in to start oscillation for  $V_{SUS} \leq V_{CC} \leq V_{SI}$ .
4.  $V_{DIS}$  and  $I_{DIS}$  are the conditions applied to trigger in to inhibit oscillation for  $V_{SI} \leq V_{CC}$ .
5. Trigger current must be limited to this value externally.

CIRCUIT CURRENT-SUPPLY VOLTAGE (NO LOAD)

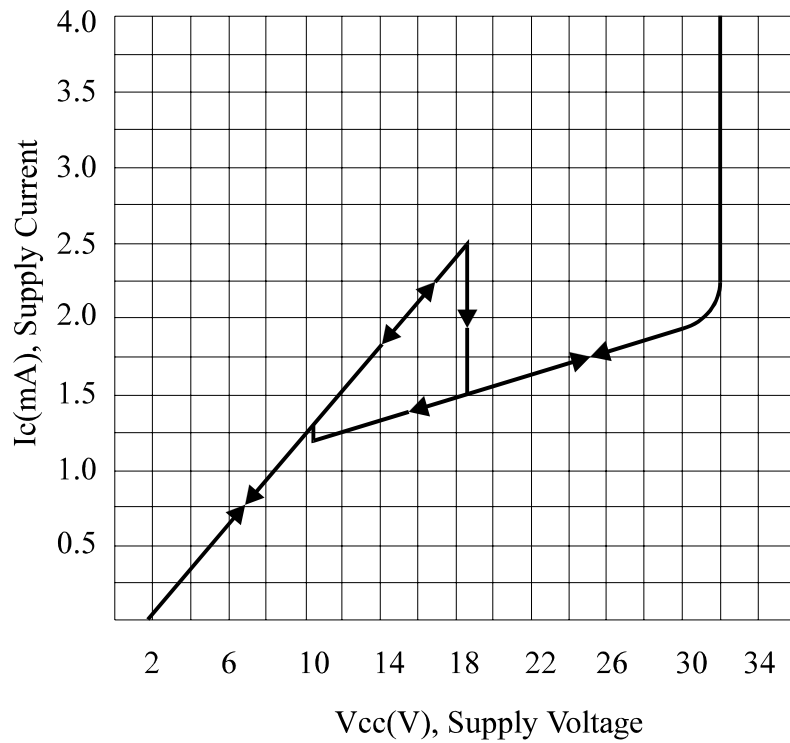


Figure 1

APPLICATION CIRCUIT

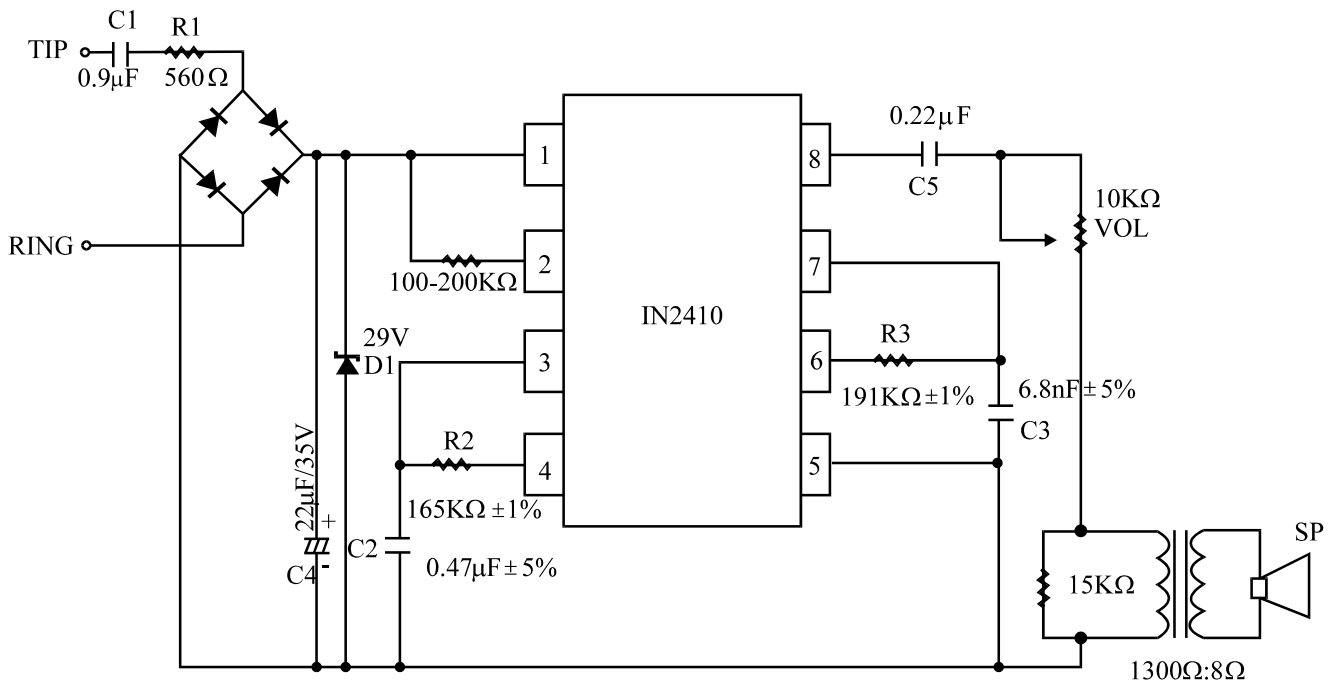


Figure 2

**APPLICATION NOTE**

The application circuit illustrates the use of the IL2410 devices in typical telephone or extension tone ringer application. The AC ringer signal voltage appears across the TIP and RING inputs of the circuit and is attenuated by capacitor  $C_1$  and resistor  $R_1$ .

$C_1$  also provides isolation from DC voltages (48V) on the exchange line.

After full wave rectification by the bridge diode, the waveform is filtered by capacitor  $C_4$  to provide a DC supply for the tone ringer chip.

As this voltage exceeds the initiation voltage ( $V_{SD}$ ), oscillation starts.

With the components shown, the output frequency chops between 512( $f_{h1}$ ) and 640Hz( $f_{h2}$ ) at a 10Hz( $f_L$ ) rate.

The loudspeaker load is coupled through a 1300 $\Omega$  to 8 $\Omega$  transformer.

The output coupling capacitor  $C_5$  is required with transformer coupled loads.

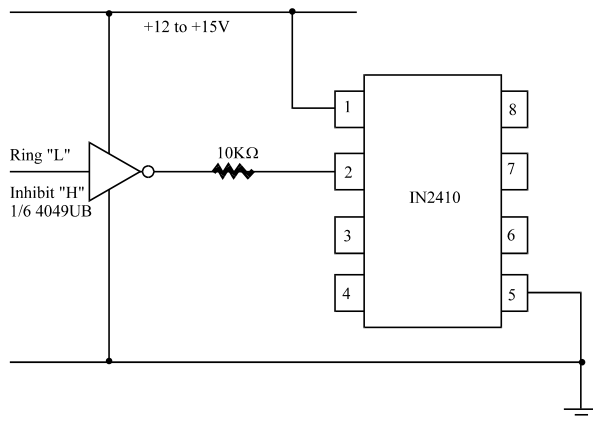
When driving a piezo-ceramic transducer type load, the coupling  $C_5$  and transformer (1300 $\Omega$ :8 $\Omega$ ) are not required.

However, a current limiting resistor is required.

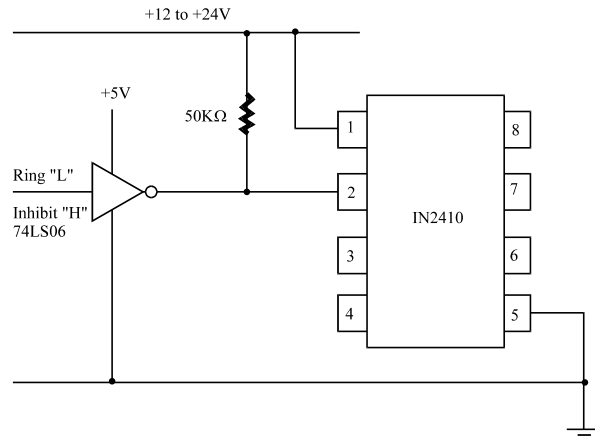
The low frequency oscillator oscillates at a rate ( $f_L$ ) controlled by an external resistor ( $R_2$ ) and capacitor ( $C_2$ ).

The frequency can be determined using the relation  $f_L=1/1.289R_2xC_2$ . The high frequency oscillates at a  $f_{H1}$ ,  $f_{H2}$  controlled by an external resistor ( $R_3$ ) and capacitor ( $C_3$ ). The frequency can be determined using the relation  $f_{H1}=1/1.504R_3xC_3$ ,  $f_{H2}=1/1.203R_3xC_3$ .

**TRIGGERING IL2410 FROM CMOS OR TTL LOGIC**

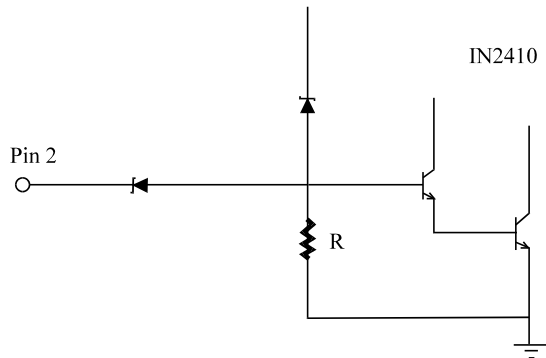


**Figure 3**



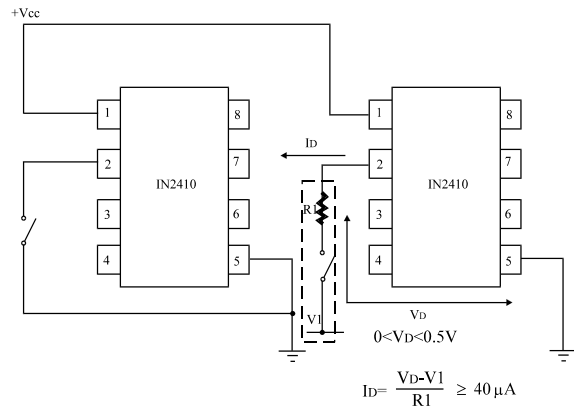
**Figure 4**

**EQUIVALENT CIRCUIT (Pin 2 Input)**



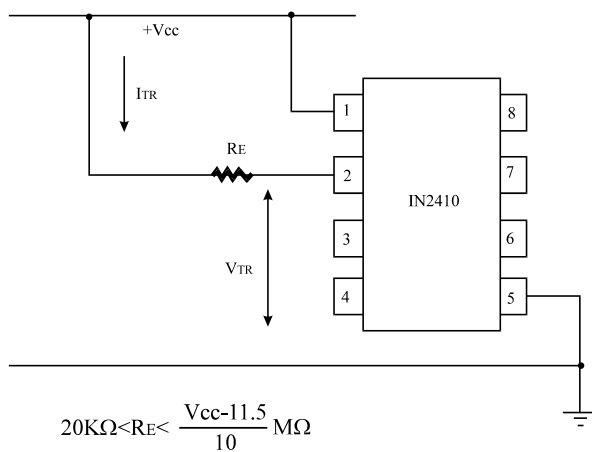
**Figure 5**

**INHIBITING OSCILLATION**

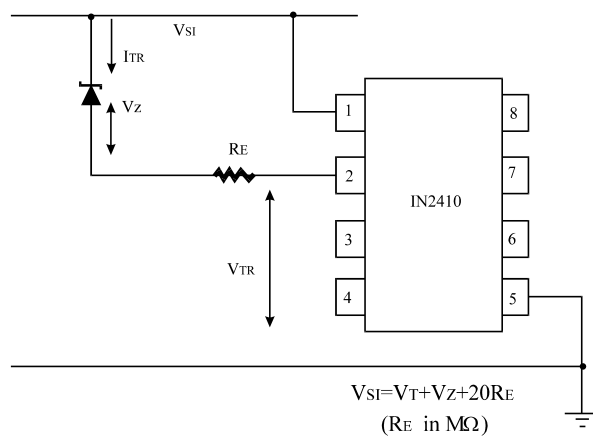


**Figure 6**

**PROGRAMMING THE IL2410 INITIATION SUPPLY VOLTAGE**

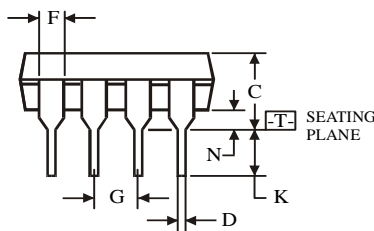
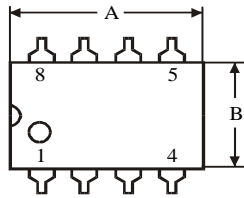
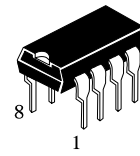


**Figure 7**



**Figure 8**

**N SUFFIX PLASTIC DIP  
(MS - 001BA)**



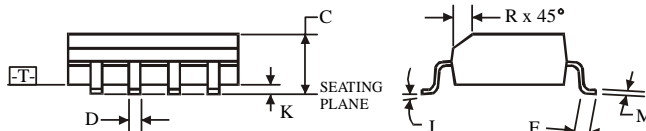
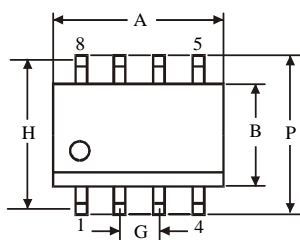
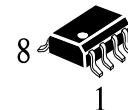
$\oplus 0.25 (0.010) \text{ (M) T}$

Symbol	Dimension, mm	
	MIN	MAX
A	8.51	10.16
B	6.1	7.11
C		5.33
D	0.36	0.56
F	1.14	1.78
G	2.54	
H	7.62	
J	0°	10°
K	2.92	3.81
L	7.62	8.26
M	0.2	0.36
N	0.38	

**NOTES:**

- Dimensions "A", "B" do not include mold flash or protrusions.  
Maximum mold flash or protrusions 0.25 mm (0.010) per side.

**D SUFFIX SOIC  
(MS - 012AA)**



$\oplus 0.25 (0.010) \text{ (M) T C (M)}$

Symbol	Dimension, mm	
	MIN	MAX
A	4.8	5
B	3.8	4
C	1.35	1.75
D	0.33	0.51
F	0.4	1.27
G	1.27	
H	5.72	
J	0°	8°
K	0.1	0.25
M	0.19	0.25
P	5.8	6.2
R	0.25	0.5

**NOTES:**

- Dimensions A and B do not include mold flash or protrusion.
- Maximum mold flash or protrusion 0.15 mm (0.006) per side  
for A; for B - 0.25 mm (0.010) per side.