

HITACHI TRANSISTORS

—FOR AUDIO FREQUENCY OUTPUT AMPLIFIER USE—

2SB370 2SB370A

The Hitachi 2SB370 and 2SB370A are germanium PNP alloyed junction type transistors, intended for use as audio frequency output stage amplifiers, with such features as relatively large allowable collector dissipation in small dimension and linear dependency of current transfer ratio on collector current up to rated value.

These transistors are effectively used as medium power output stage amplifiers of portable radios, car radio receivers, tape recorders, and so on.

ABSOLUTE MAXIMUM RATINGS (At 25°C Ambient Temperature)

Item	Symbol	2SB370	2SB370A	Unit
Collector to Base Voltage	V_{CBO}	-25	-32	V
Collector to Emitter Voltage	V_{CES}	-25	-32	V
	V_{CEO}	-18	-25	V
Emitter to Base Voltage	V_{EBO}	-6	-12	V
Peak Collector Current	$i_{C(peak)}$	-1	-1	A
Collector Current	I_C	-500	-500	mA
Emitter Current	I_E	500	500	mA
Collector Dissipation	P_C	200	200	mW
Collector Dissipation*	P_C	600	600	mW
Junction Temperature	T_j	85	85	°C
Storage Temperature	T_{stg}	-55~+85	-55~+85	°C

* Value when attached on the heat sink plate (35mm×35mm×1.5mm aluminium) by heat sink fin (NZ1B).

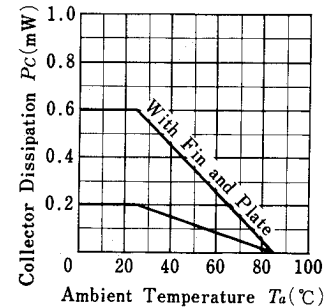
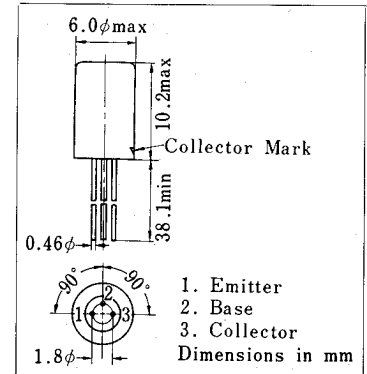

Maximum Collector Dissipation Curve

ELECTRICAL CHARACTERISTICS (At 25°C Ambient Temperature)

Item	Symbol	Condition of Measurement	2SB370			2SB370A			Unit
			min.	typ.	max.	min.	typ.	max.	
Collector to Base Breakdown Voltage	BV_{CBX}	$I_C = -100\mu A, V_{EB} = -6V$	-25	—	—	-32	—	—	V
Collector Cut-off Current	I_{CBO}	$V_{CB} = -12V, I_E = 0$	—	—	-20	—	—	-20	μA
		$V_{CE} = -25V, R_{BE} = 0$	—	—	-5	—	—	-5	mA
Collector Cut-off Current	I_{CES}	$V_{CE} = -32V, R_{BE} = 0$	—	—	—	—	—	-5	mA
		$V_{CE} = -18V, R_{BE} = \infty$	—	—	-5	—	—	—	mA
Collector Cut-off Current	I_{CEO}	$V_{CE} = -25V, R_{BE} = \infty$	—	—	—	—	—	-5	mA
		$V_{EB} = -6V, I_C = 0$	—	—	-20	—	—	—	μA
Emitter Cut-off Current	I_{EBO}	$V_{EB} = -12V, I_C = 0$	—	—	—	—	—	-20	μA
		$V_{CE} = -1V, I_C = -150mA$	70	150	300	70	150	300	
DC Current Transfer Ratio	h_{FE}	$V_{CE} = -1V, I_C = -150mA$	70	150	300	70	150	300	
Small Signal Current Transfer Ratio	h_{fe}	$V_{CE} = -6V, I_C = -1mA, f = 270Hz$	—	110	—	—	110	—	

* The 2SB370 and 2SB370A are grouped by h_{FE} as follows.

Ⓐ 70~125 Ⓑ 110~200 Ⓒ 160~300

MAXIMUM RATINGS

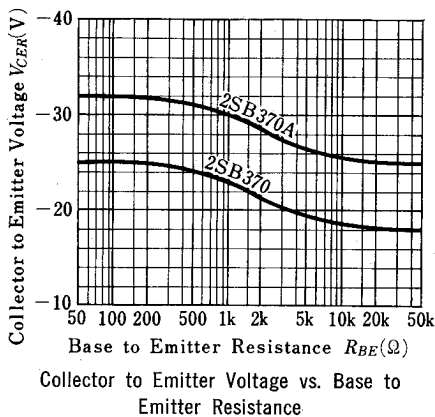

STATIC CHARACTERISTICS

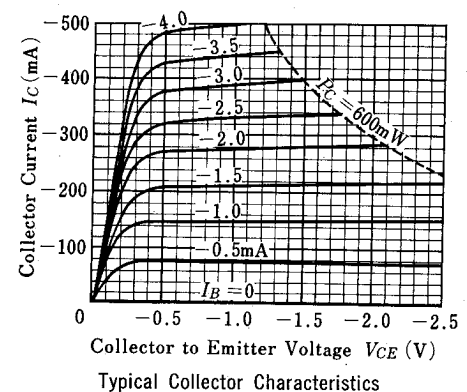
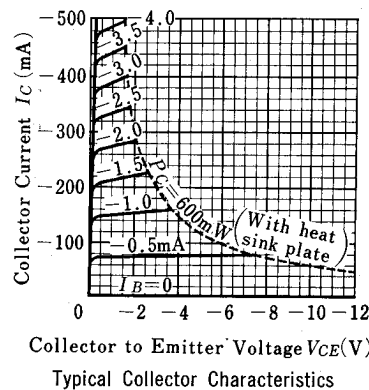

Circuit 2—Class B SEPP Amplifier

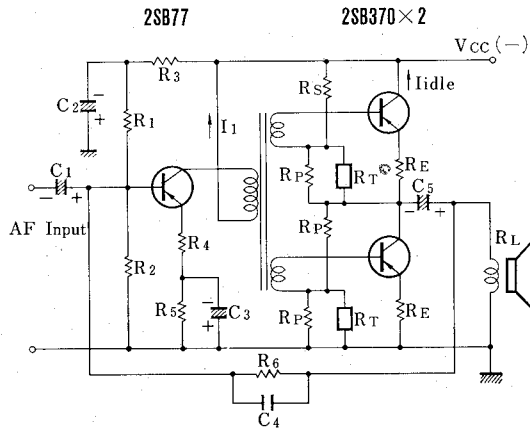

Circuit 3—Class B Push—Pull Amplifier

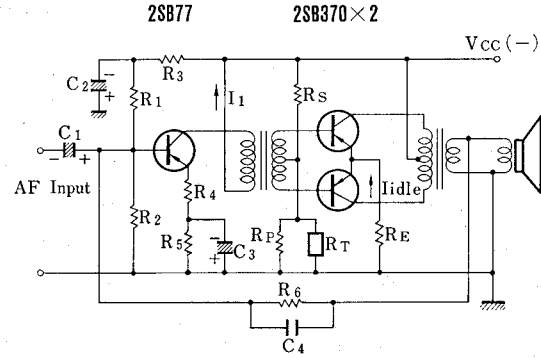

Typical Operation of Power Output up to 2W

Item	Symbol	Typical Operation						Unit				
		Circuit 1		Circuit 2		Circuit 3						
Supply Voltage (Note 1)		V_{cc}	-9	-12	-9	-12	-6	-9	-12	V		
Performance Data	Maximum Power Output (at 5% Distortion)	P_{om}	0.6	1.3	0.7	2.0	1.0	1.5	2.0	W		
	Power Gain (Output Stage)	PG	51	48	27	28	28	25.5	28	dB		
Parts Spec.	Input Transformer	Primary	Impedance	Z_i	—	—	4.5	3.5	2.5	2.0	3.5	k Ω
			Max. DC Resistance	R_i	—	—	300	100	100	100	100	Ω
	Secondary (Note 2)	Impedance	Z_o	—	—	0.36	0.3	1.4	3.2	3.2	k Ω	
		Max. DC Resistance	R_o	—	—	30	30	30	80	80	Ω	
	Resistor	R_L (Note 3)		8	8	8	4	40	50	90	Ω	
		R_1		36	30	20	15	16	19	20	k Ω	
		R_2		5	5	7	7	5	7	8	k Ω	
		R_3		5k	5k	200	200	200	200	200	Ω	
		R_4		100	100	10	10	5	10	10	Ω	
		R_5		500	500	700	1000	700	1000	1000	Ω	
R_6			3	3	50	50	50	70	70	k Ω		
R_7 (Variable)			10	10	—	—	—	—	—	k Ω		
R_8			1.5	0.7	—	—	—	—	—	k Ω		
R_9			50	55	—	—	—	—	—	Ω		
Capacitor	R_{10}		100	100	—	—	—	—	—	Ω		
	R_{11}		250	125	—	—	—	—	—	Ω		
	R_{12}		250	125	—	—	—	—	—	Ω		
	R_E		1.3	1.0	2	1.5	2	5	5	Ω		
	R_S		500	500	1.5	0.67	2.8	3.3	4.4	k Ω		
	R_T (Thermistor)		D-1E	D-1E	D-1E	D-1A	D-1E	D-1E	D-1E			
	R_P		90	75	150	50	200	150	150	Ω		
	C_1		10	10	10	10	10	10	10	μF		
	C_2		100	100	100	100	100	100	100	μF		
	C_3		50	50	100	100	50	50	50	μF		
Collector Current	Driver Stage	I_1	4	6	2.7	3.3	2.0	2.5	3.3	mA		
		Output Stage	Zero Signal Bias	I_{idle}	6.5	6.5	6	6	6	6	mA	
			Peak Value	i_{cp}	155	192	420	1000	417	500	430	mA
			Average (at P_{om})	$i_{cp(av)}$	—	—	134	320	133	159	137	mA
	C_4		30 μ	30 μ	200p	200p	200p	100p	100p	μF		
	C_5		500	500	300	300	—	—	—	μF		
	C_6		100	100	—	—	—	—	—	μF		
	C_7		50	50	—	—	—	—	—	μF		
	C_8		700	700	—	—	—	—	—	pF		
	C_9		100	100	—	—	—	—	—	μF		
C_{10}		0.015	0.02	—	—	—	—	—	μF			

- (Note 1) When $V_{cc} = -9, -12V$, attach the output pair on the heat sink plate (100mm×100mm×1.5mm Al-plate) by using heat sink fin NZ16, or NZ1B.
- (Note 2) Secondary impedance and DC resistance of driver transformer are specified as follows.
For Circuit 2: Value of Each Winding
For Circuit 3: Value of Base to Base
- (Note 3) For Circuit 3 (Class B P-P Amp)
Load resistance R_L is specified by primary impedance of output transformer (Collector to Collector)



Head Office: 4, 1-chome, Marunouchi, Chiyoda-ku, Tokyo
 Tel. Tokyo (212) 1111 (80 lines)
 Cable Address: "HITACHY" TOKYO
 Codes: All Codes Used

For inquiry write to:

New York Hitachi Sales Corporation
 666 Fifth Avenue
 New York, N.Y. 10019, U.S.A.
 Chicago Hitachi Sales Corporation
 333 North Michigan Avenue
 Chicago, Ill. 60601, U.S.A.
 Düsseldorf Mr. K. Kakurai
 400 Düsseldorf
 Graf-Adolf-Strasse 37, West Germany