

Dual Digitally Controlled Potentiometers (XDCPs™)

FEATURES

- **Dual solid-state potentiometers**
- **Independent Up/Down interfaces**
- **32 wiper tap points per potentiometer**
 - Wiper position stored in nonvolatile memory and recalled on power-up
- **31 resistive elements per potentiometer**
 - Temperature compensated
 - Maximum resistance tolerance of $\pm 30\%$
 - Terminal voltage, 0 to V_{CC}
- **Low power CMOS**
 - $V_{CC} = 3V \pm 10\%$
 - Active current, 250 μ A max
 - Standby current, 1 μ A max
- **High reliability**
 - Endurance 200,000 data changes per bit
 - Register data retention, 100 years
- R_{TOTAL} value = 50k Ω
- 14-lead TSSOP package

DESCRIPTION

The Intersil X93254 is a dual digitally controlled potentiometer (XDCP). The device consists of two resistor arrays, wiper switches, a control section, and nonvolatile memory. The wiper positions are controlled by individual Up/Down interfaces.

A potentiometer is implemented by a resistor array composed of 31 resistive elements and a wiper switching network. The position of each wiper element is controlled by a set of independent \overline{CS} , U/\overline{D} , and \overline{INC} inputs. The position of the wiper can be stored in non-volatile memory and then be recalled upon a subsequent power-up operation.

Each potentiometer is connected as a two-terminal variable resistor and can be used in a wide variety of applications including:

- Bias and Gain control
- LCD Contrast Adjustment

BLOCK DIAGRAM

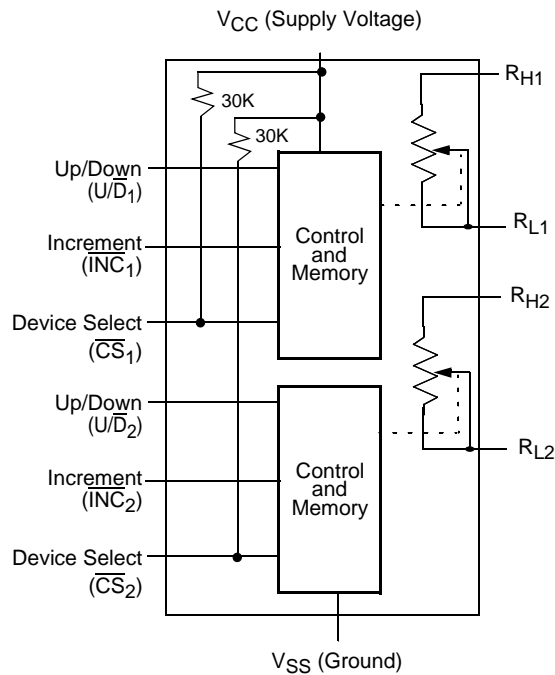

X93254

PIN CONFIGURATION

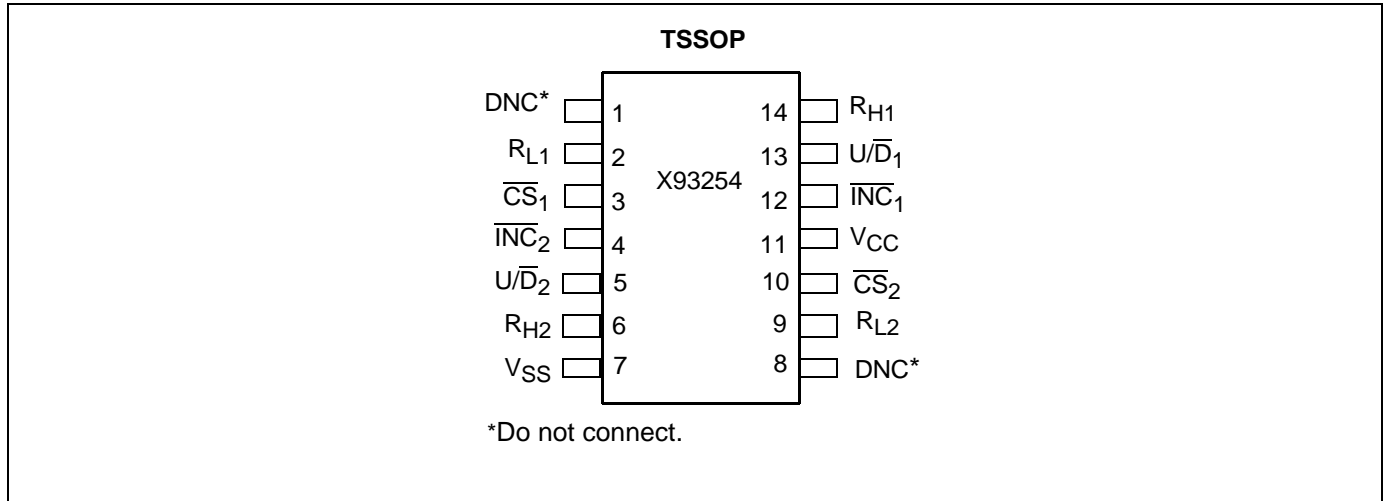

X93254 ORDERING CODES

Ordering Number	RTOTAL	Package	Temperature Range
X93254UV14I-3	50kΩ	14-lead TSSOP package	-40°C to +85°C

PIN DESCRIPTIONS

TSSOP	Symbol	Description
1	DNC	Do Not Connect.
2	R _{L1}	Low Terminal 1.
3	CS ₁	Chip Select 1.
4	INC ₂	Increment 2.
5	U/D ₂	Up/Down 2.
6	R _{H2}	High Terminal 2.
7	V _{SS}	Ground.
8	DNC	Do Not Connect.
9	R _{L2}	Low Terminal 2.
10	CS ₂	Chip Select 2.
11	V _{CC}	Supply Voltage.
12	INC ₁	Increment 1.
13	U/D ₁	Up/Down 1.
14	R _{H1}	High Terminal 1.

ABSOLUTE MAXIMUM RATINGS

Temperature under bias -65°C to +135°C
 Storage temperature -65°C to +150°C
 Voltage on \overline{CS} , \overline{INC} , U/\overline{D} , R_H , R_L and V_{CC}
 with respect to V_{SS} -1V to +6.5V
 Lead temperature (soldering 10 seconds) 300°C
 Maximum reflow temperature (40 seconds) 240°C
 Maximum resistor current 2mA

COMMENT

Stresses above those listed under “Absolute Maximum Ratings” may cause permanent damage to the device. This is a stress rating only; the functional operation of the device (at these or any other conditions above those listed in the operational sections of this specification) is not implied. Exposure to absolute maximum rating conditions for extended periods may affect device reliability.

RECOMMENDED OPERATING CONDITIONS

Temperature	Min.	Max.
Industrial	-40°C	+85°C

Supply Voltage (V_{CC})	Limits
X93254	3V ± 10% ⁽⁷⁾

POTENTIOMETER CHARACTERISTICS (Over recommended operating conditions unless otherwise stated.)

Symbol	Parameter	Limits				Test Conditions/Notes
		Min.	Typ.	Max.	Unit	
R_{TOT}	End to end resistance	37.5	50	62.5	k Ω	(5)
V_R	R_H , R_L terminal voltages	0		V_{CC}	V	(5)
	Power rating			1	mW ⁽⁶⁾	$R_{TOTAL} = 50k\Omega$ ⁽⁵⁾
	Noise		-120		dBV ⁽⁶⁾	Ref: 1kHz ⁽⁵⁾
R_W	Wiper Resistance			1000	Ω	(5) (6)
I_W	Wiper Current			0.6	mA	(5) (6)
	Resolution		3		%	(5)
	Absolute linearity ⁽¹⁾			±1	MI ⁽³⁾	$V_{H(n)(actual)} - V_{H(n)(expected)}$ ⁽⁵⁾
	Relative linearity ⁽²⁾			±0.5	MI ⁽³⁾	$V_{H(n+1)} - [V_{H(n)} + MI]$ ⁽⁵⁾
	R_{TOTAL} temperature coefficient		±35		ppm/°C	(5) (6)
$C_H/C_L/C_W$	Potentiometer capacitances		10/10/25		pF	See circuit #2 ⁽⁵⁾

- Notes: (1) Absolute linearity is utilized to determine actual wiper voltage versus expected voltage = $(V_{H(n)(actual)} - V_{H(n)(expected)}) = \pm 1$ MI Maximum. n = 1 .. 29 only
 (2) Relative linearity is a measure of the error in step size between taps = $V_{H(n+1)} - [V_{H(n)} + MI] = \pm 0.5$ MI, n = 1 .. 29 only.
 (3) 1 MI = Minimum Increment = $R_{TOT}/31$.
 (4) Typical values are for $T_A = 25^\circ C$ and nominal supply voltage.
 (5) This parameter only applies to a single potentiometer.
 (6) This parameter is guaranteed by characterization.
 (7) When performing multiple write operations, V_{CC} must not decrease by more than 150mV from its initial value.

D.C. OPERATING CHARACTERISTICS (Over recommended operating conditions unless otherwise specified.)

Symbol	Parameter	Limits			Unit	Test Conditions
		Min.	Typ.(4)	Max.		
I _{CC1}	V _{CC} active current (Increment) per DCP		50	250	μA	$\overline{CS} = V_{IL}, U/\overline{D} = V_{IL} \text{ or } V_{IH} \text{ and } \overline{INC} = 0.4V @ \text{max. } t_{CY}^{(5)}$
I _{CC2}	V _{CC} active current (Store) (EEPROM Store) per DCP			600	μA	$\overline{CS} = V_{IH}, U/\overline{D} = V_{IL} \text{ or } V_{IH} \text{ and } \overline{INC} = V_{IH} @ \text{max. } t_{WR}^{(5)}$
I _{SB}	Standby supply current			1	μA	$\overline{CS} = V_{CC} - 0.3V, U/\overline{D}$ and $\overline{INC} = V_{SS} \text{ or } V_{CC} - 0.3V$
I _{LI}	\overline{CS}_1 or \overline{CS}_2			±1	μA	V _{IN} = V _{CC} (5)
I _{LI}	\overline{CS}_1 or \overline{CS}_2	60	100	150	μA	V _{CC} = 3V, $\overline{CS} = 0^{(5)}$
I _{LI}	$\overline{INC}_1, \overline{INC}_2, U/\overline{D}_1, U/\overline{D}_2$ input leakage current			±1	μA	V _{IN} = V _{SS} to V _{CC} (5)
V _{IH}	$\overline{CS}_1, \overline{CS}_2, \overline{INC}_1, \overline{INC}_2, U/\overline{D}_1, U/\overline{D}_2$ input HIGH voltage	V _{CC} x 0.7		V _{CC} + 0.5	V	(5)
V _{IL}	$\overline{CS}_1, \overline{CS}_2, \overline{INC}_1, \overline{INC}_2, U/\overline{D}_1, U/\overline{D}_2$ input HIGH voltage	-0.5		V _{CC} x 0.1	V	(5)
C _{IN}	$\overline{CS}_1, \overline{CS}_2, \overline{INC}_1, \overline{INC}_2, U/\overline{D}_1, U/\overline{D}_2$ input capacitance			10	pF	V _{CC} = 3V, V _{IN} = V _{SS} , T _A = 25°C, f = 1MHz(6)

ENDURANCE AND DATA RETENTION

Parameter	Min.	Unit
Minimum endurance	200,000	Data changes per bit
Data retention	100	Years

Test Circuit #1

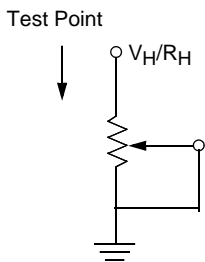

Circuit #2 SPICE Macro Model

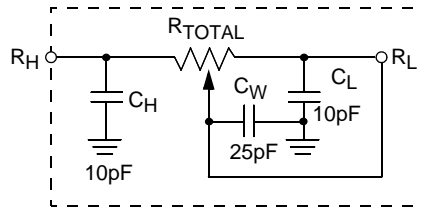

A.C. CONDITIONS OF TEST

Input pulse levels	0V to 3V
Input rise and fall times	10ns
Input reference levels	1.5V

A.C. OPERATING CHARACTERISTICS (Over recommended operating conditions unless otherwise specified. In the table, \overline{CS} , \overline{INC} , U/\overline{D} , R_H and R_L are used to refer to either \overline{CS}_1 or \overline{CS}_2 , etc.)

Symbol	Parameter	Limits			Unit
		Min.	Typ. ⁽⁶⁾	Max.	
t_{CI}	\overline{CS} to \overline{INC} setup	100			ns
t_{ID}	\overline{INC} HIGH to U/\overline{D} change	100			ns
t_{DI}	U/\overline{D} to \overline{INC} setup	100			ns
t_{IL}	\overline{INC} LOW period	1			μ s
t_{IH}	\overline{INC} HIGH period	1			μ s
t_{IC}	\overline{INC} Inactive to \overline{CS} inactive	1			μ s
t_{CPH}	\overline{CS} Deselect time (NO STORE)	250			ns
t_{CPH}	\overline{CS} Deselect time (STORE)	10			ms
t_{CYC}	\overline{INC} cycle time	2			μ s
$t_R, t_F^{(6)}$	\overline{INC} input rise and fall time			500	μ s
$t_R V_{CC}^{(6)}$	V_{CC} power-up rate	1		10,000	V/ms
t_{WR}	Store cycle		5	10	ms

POWER-UP AND DOWN REQUIREMENTS

There are no restrictions on the power-up or power-down conditions of V_{CC} and the voltages applied to the potentiometer pins provided that V_{CC} is always more positive than or equal to V_H and V_L , i.e., $V_{CC} \geq V_H, V_L$. The V_{CC} ramp rate spec is always in effect.

A.C. TIMING (In the diagram, \overline{CS} , \overline{INC} , U/\overline{D} , R_H and R_L are used to refer to either \overline{CS}_1 or \overline{CS}_2 , etc.)

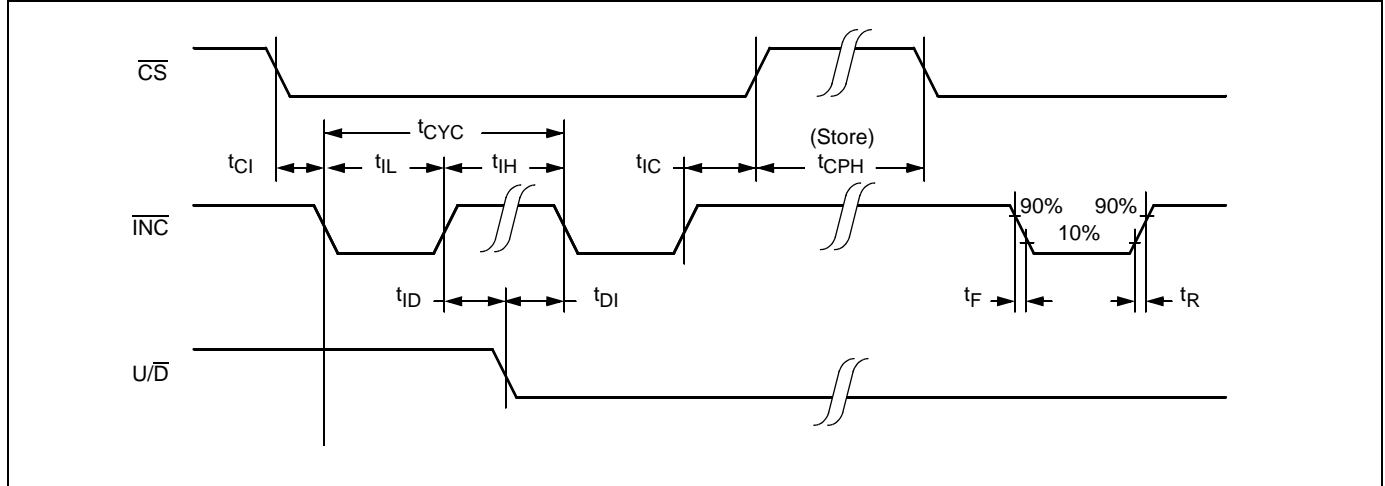

PIN DESCRIPTIONS

(In the text, \overline{CS} , \overline{INC} , U/\overline{D} , R_H and R_L are used to refer to either \overline{CS}_1 or \overline{CS}_2 , etc. Note: These signals can be applied independently or at the same time.)

R_H and R_L

The R_H and R_L pins of the X93254 are equivalent to the fixed terminals of a mechanical potentiometer. The minimum voltage is V_{SS} and the maximum is V_{CC} . The terminology of R_H and R_L references the relative position of the terminal in relation to wiper movement direction selected by the U/\overline{D} input per potentiometer.

Up/Down (U/\overline{D})

The U/\overline{D} input controls the direction of a single potentiometer's wiper movement and whether the counter is incremented or decremented.

Increment (\overline{INC})

The \overline{INC} input is negative-edge triggered. Toggling \overline{INC} will move the wiper and either increment or decrement the corresponding potentiometer's counter in the direction indicated by the logic level on the corresponding potentiometer's U/\overline{D} input.

Chip Select (\overline{CS})

A potentiometer is selected when the corresponding \overline{CS} input is LOW. Its current counter value is stored in nonvolatile memory when the corresponding \overline{CS} is returned HIGH while the corresponding \overline{INC} input is also HIGH. After the store operation is complete the affected potentiometer will be placed in the low power standby mode until the potentiometer is selected once again.

PRINCIPLES OF OPERATION

There are multiple sections for each potentiometer in the X93254: an input control, a counter and decode section; the nonvolatile memory; and a resistor array. Each input control section operates just like an up/down counter. The output of this counter is decoded to turn on a single electronic switch connecting a point on the resistor array to the wiper output. Under the proper conditions the contents of the counter can be stored in nonvolatile memory and retained for future use. Each resistor array is comprised of 31 individual resistors connected in series. At either end of the array and between each resistor is an electronic switch that transfers the connection at that point to the wiper.

Each wiper, when at either fixed terminal, acts like its mechanical equivalent and does not move beyond the last position. That is, the counter does not wrap around when clocked to either extreme.

If the wiper is moved several positions, multiple taps are connected to the wiper for t_{1W} (INC to V_W change). The 2-terminal resistance value for the device can temporarily change by a significant amount if the wiper is moved several positions.

When the device is powered-down, the last wiper position stored will be maintained in the nonvolatile memory for each potentiometer. When power is restored, the contents of the memory are recalled and each wiper is set to the value last stored.

INSTRUCTIONS AND PROGRAMMING

The \overline{INC} , U/\overline{D} and \overline{CS} inputs control the movement of the wiper along the resistor array. With \overline{CS} set LOW the potentiometer is selected and enabled to respond to the U/\overline{D} and \overline{INC} inputs. HIGH to LOW transitions on \overline{INC} will increment or decrement (depending on the state of the U/\overline{D} input) a five bit counter. The output of this counter is decoded to select one of thirty two wiper positions along the resistive array.







The value of the counter is stored in nonvolatile memory whenever each \overline{CS} transitions HIGH while the \overline{INC} input is also HIGH. In order to avoid an accidental store during power-up, each \overline{CS} must go HIGH with V_{CC} during initial power-up. When left open, each \overline{CS} pin is internally pulled up to V_{CC} by an internal 30K resistor.

The system may select the X93254, move any wiper and deselect the device without having to store the latest wiper position in nonvolatile memory. After the wiper movement is performed as described above and once the new position is reached, the system must keep \overline{INC} LOW while taking \overline{CS} HIGH. The new wiper position will be maintained until changed by the system or until a power-up/down cycle recalled the previously stored data. In order to recall the stored position of the wiper on power-up, the \overline{CS} pin must be held HIGH.





This procedure allows the system to always power-up to a preset value stored in nonvolatile memory; then during system operation minor adjustments could be made. The adjustments might be based on user preference, system parameter changes due to temperature drift, or other system trim requirements.

The state of $\overline{U/D}$ may be changed while \overline{CS} remains LOW. This allows the host system to enable the device and then move each wiper up and down until the proper trim is attained.

MODE SELECTION

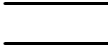
\overline{CS}	\overline{INC}	$\overline{U/D}$	Mode
L		H	Wiper Up
L		L	Wiper Down
	H	X	Store Wiper Position
H	X	X	Standby Current
	L	X	No Store, Return to Standby
	L	H	Wiper Up (not recommended)
	L	L	Wiper Down (not recommended)

SYMBOL TABLE

WAVEFORM	INPUTS	OUTPUTS
	Must be steady	Will be steady
	May change from Low to High	Will change from Low to High
	May change from High to Low	Will change from High to Low
	Don't Care: Changes Allowed	Changing: State Not Known
	N/A	Center Line is High Impedance

APPLICATIONS INFORMATION

Electronic digitally controlled (XDCP) potentiometers provide three powerful application advantages; (1) the variability and reliability of a solid-state potentiometer (2) the flexibility of computer-based digital controls, and (3) the retentivity of nonvolatile memory used for the storage of multiple potentiometer settings or data.

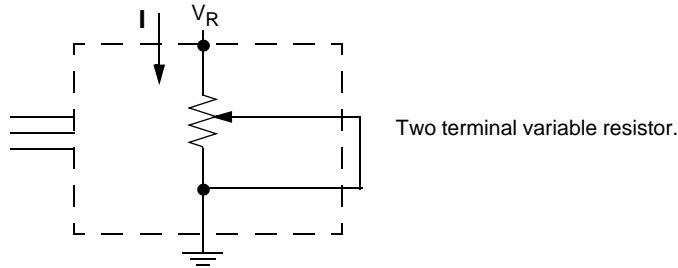

Low Voltage High Impedance Instrumentation Amplifier

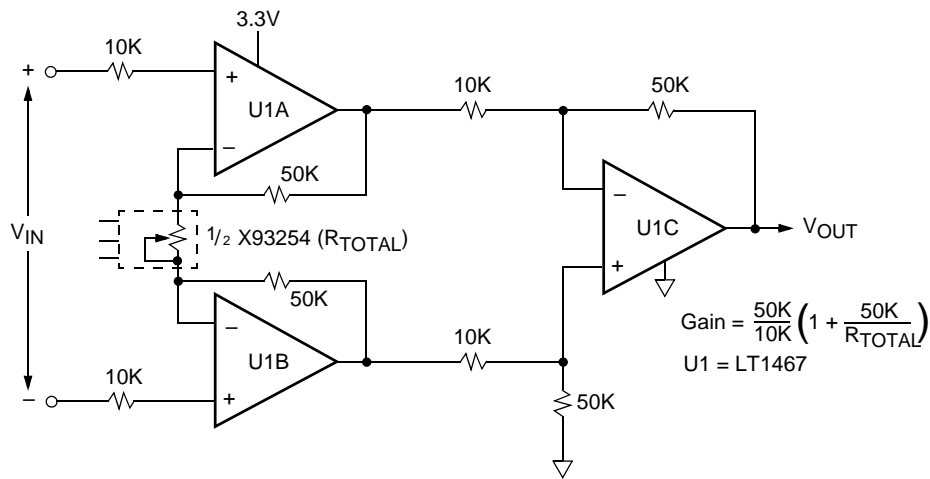

Micro-Power LCD Contrast Control

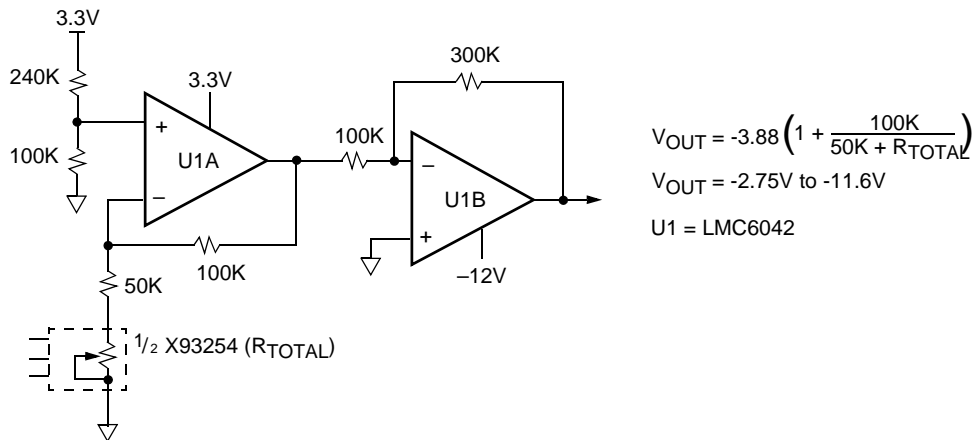

APPLICATIONS INFORMATION (Continued)

Single Supply Variable Gain Amplifier

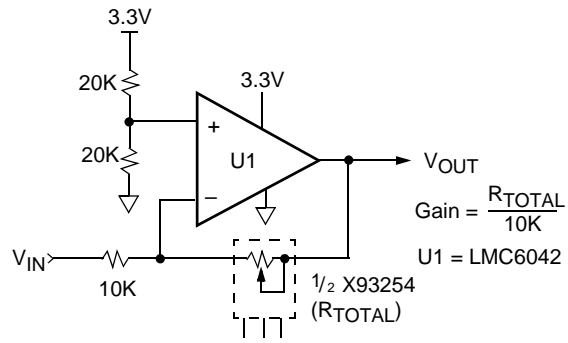

PACKAGING INFORMATION

14-Lead Plastic, TSSOP, Package Code V14

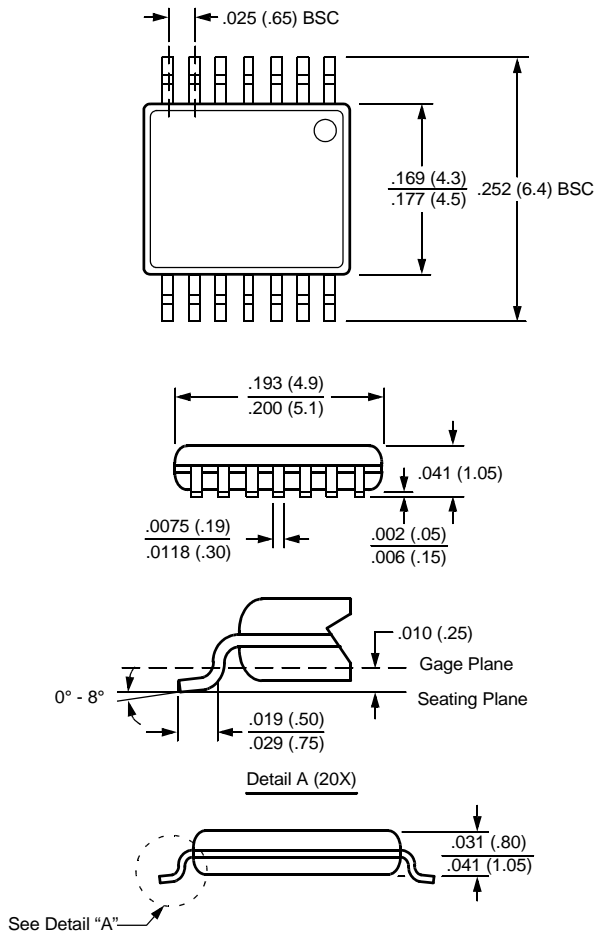

NOTE: ALL DIMENSIONS IN INCHES (IN PARENTHESES IN MILLIMETERS)

All Intersil U.S. products are manufactured, assembled and tested utilizing ISO9000 quality systems.
Intersil Corporation's quality certifications can be viewed at www.intersil.com/design/quality

Intersil products are sold by description only. Intersil Corporation reserves the right to make changes in circuit design, software and/or specifications at any time without notice. Accordingly, the reader is cautioned to verify that data sheets are current before placing orders. Information furnished by Intersil is believed to be accurate and reliable. However, no responsibility is assumed by Intersil or its subsidiaries for its use; nor for any infringements of patents or other rights of third parties which may result from its use. No license is granted by implication or otherwise under any patent or patent rights of Intersil or its subsidiaries.

For information regarding Intersil Corporation and its products, see www.intersil.com