

**DESCRIPTION**

The LX7203 is an integrated Universal Serial Bus (USB) line termination device with an EMI filter and ESD protection diodes. This device offers a cost effective and compact solution for one USB upstream port. The USB v1.1 specification requires line termination resistors on both the D+ and D- lines. These resistors ensure signal integrity by matching the cable impedance to that of the differential driver. The 1.5 k $\Omega$  pull-up resistor identifies the appropriate data line for full speed or low speed operation.

The 47 pF capacitor completes the high frequency filter and controls the edge rate of the USB signals. The LX7203 protects both D+ and D- data lines and the voltage bus from ESD. The TVS protection diodes exceed the requirements of IEC61000-4-2, level 4, 15kV (air discharge) and 8kV (contact discharge). The integrated configuration of the LX7203 minimizes board space and allows for ideal placement near the connector. The LX7203 is ideal for use in USB hubs, peripherals and portable appliances.

**IMPORTANT:** For the most current data, consult MICROSEMI's website: <http://www.microsemi.com>

**KEY FEATURES**

- Small SC70-6L Package
- Bi-directional EMI/RFI low-pass filter
- Line termination with integrated ESD protection
- Low TVS operating voltage (5.25V)
- Low leakage current
- Integrated single die construction
- Crosses From Semtech STF203

**APPLICATIONS**

- USB Ports
- Peripherals
- Computers and Printers
- Mobile phones
- Pagers and PDA's
- Digital Cameras

**PACKAGE ORDER INFO**

T <sub>J</sub> (°C)	SM	Plastic 6-Pin SC70	Package Marking	Tape & Reel Quantity (Reel Size)
-40 to 125		LX7203-15ISM	315	3K (7inches)
-40 to 125		LX7203-22ISM	322	

Note: Append the letter "T" to the part number  
For Tape & Reel Ordering

**BENEFITS**

- Filter response characterized up to 6 GHz
- <2dB insertion loss in the pass band
- >20dB attenuation in the 800-900 MHz range
- >12dB attenuation in the WLAN frequencies of 2.4GHz and 5.0-6.0 GHz

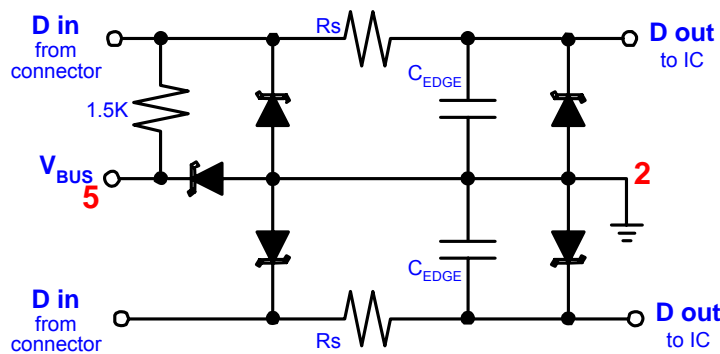
**PRODUCT HIGHLIGHT**

Circuit Diagram

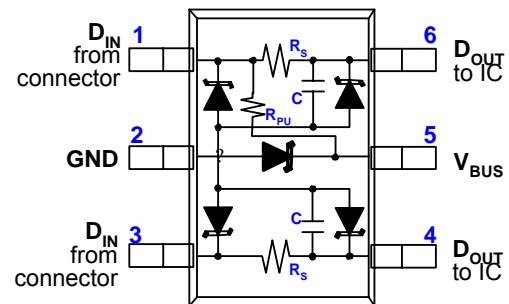

Functional Schematic with PinOut

**EMI Filter & ESD Protection for Up Stream USB Ports**
**PRODUCTION DATA SHEET**
**ABSOLUTE MAXIMUM RATINGS**

Steady State Power .....	100mW
ESD Air Discharge per IEC61000-4-2.....	16kV
ESD Contact Discharge per IEC61000-4-2.....	10kV
Lead Soldering Temperature (10 Seconds) .....	260°C
Operating Temperature .....	-40°C to +125°C
Storage Temperature Range .....	-55°C to +150°C

Note: Exceeding these ratings could cause damage to the device. All voltages are with respect to Ground. Currents are positive into, negative out of specified terminal.

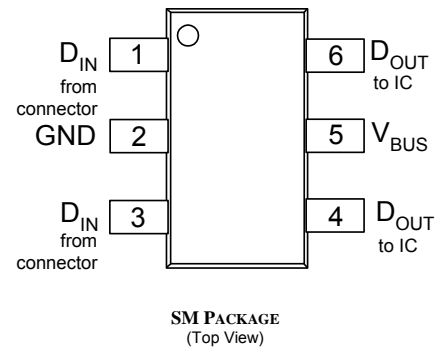
**PACKAGE PIN OUT**

**THERMAL DATA**
**SM Plastic 6-Pin SC70**

<b>THERMAL RESISTANCE-JUNCTION TO CASE, <math>\theta_{JC}</math></b>	<b>119 °C/W</b>
<b>THERMAL RESISTANCE-JUNCTION TO AMBIENT, <math>\theta_{JA}</math></b>	<b>122 °C/W</b>

Junction Temperature Calculation:  $T_J = T_A + (P_D \times \theta_{JA})$ .

The  $\theta_{JA}$  numbers are guidelines for the thermal performance of the device/pc-board system. All of the above assume no ambient airflow.

**FUNCTIONAL PIN DESCRIPTION**

Name	Description
VBUS	Bus Voltage
DIN	Data In
GND	Ground
DOUT	Data Out

**ELECTRICAL CHARACTERISTICS**

Unless otherwise specified, the following specifications apply over the operating ambient temperature  $-40^\circ\text{C} \leq T_A \leq +125^\circ\text{C}$  except where otherwise noted.

Parameter	Symbol	Test Conditions	LX7203			Units
			Min	Typ	Max	
Stand-Off Voltage	$V_{RWM}$				5.25	V
Breakdown Voltage	$V_{BR}$	$I_R = 1\text{mA}$	6			V
Leakage Current	$I_R$	$V_{RWM} = 5.25\text{V}, T = 25^\circ\text{C}$			1	$\mu\text{A}$
Series Resistance (-15)	$R_S$	Each Line	13.5	15	16.5	$\Omega$
Series Resistance (-22)	$R_S$	Each Line	19.8	22	24.2	$\Omega$
Temperature Coefficient of $R_S$	$T_{COEFF}$	Each Line		200		ppm
Pull Up Resistance	$R_{PU}$	Each Line	1.35	1.5	1.65	$\text{K}\Omega$
Capacitor	$C_{EDGE}$	Each Line		47		pF
Total Capacitance	$C_{TOT}$	Between I/O Pins and Ground, Each Device $V_R = 0\text{V}, f = 1\text{MHz}$	54	60	66	pF

**APPLICATION CIRCUITS**

Figure 1 – Typical Application

**APPLICATION INFORMATION**

The LX7203 meets the requirements of the USB v1.1 specification for device termination, EMI filtering and ESD protection. The  $R_S$  resistor provides the proper signal termination; the  $C_{EDGE}$  capacitor controls the signal rise and fall slew; the TVS diodes protect the IC from ESD damage; and the total capacitance and resistance creates a low pass filter eliminating the high frequency energy from the circuit. The LX7203 can configure the upstream port for either Full-Speed or Low-Speed operation. The figures below show the proper connection in accordance with the USB v1.1 specification.

**FULL SPEED DEVICE (FIGURE 2)**

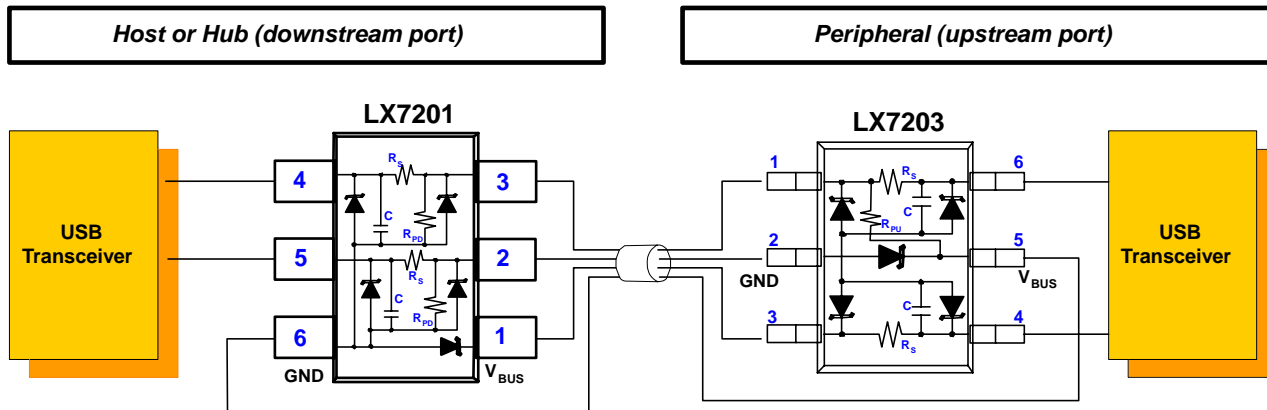
The USB specification offers a 12 Mbps data transfer rate known as Full-Speed which requires a 1.5 k $\Omega$  pull-up resistor to be connected to the D+ line. Slew rate control is accomplished with  $C_{EDGE}$  attached to the transceiver before the  $R_S$ .

- Voltage Supply (Vbus) is connected to Pin 5
- Ground is connected to Pin 2
- D+ from the connector is routed to Pin 1 (1.5 k $\Omega$  pull-up resistor) and Pin 6 to the D+ line of the USB Transceiver
- D- from the connector is routed to Pin 3 and Pin 4 to the D- line of the USB Transceiver

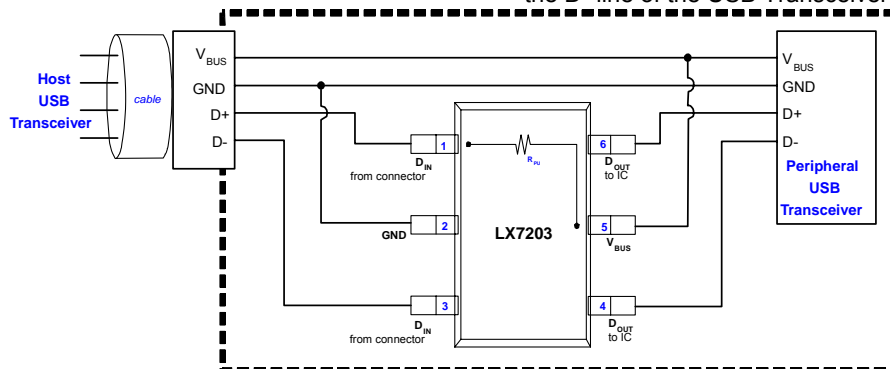
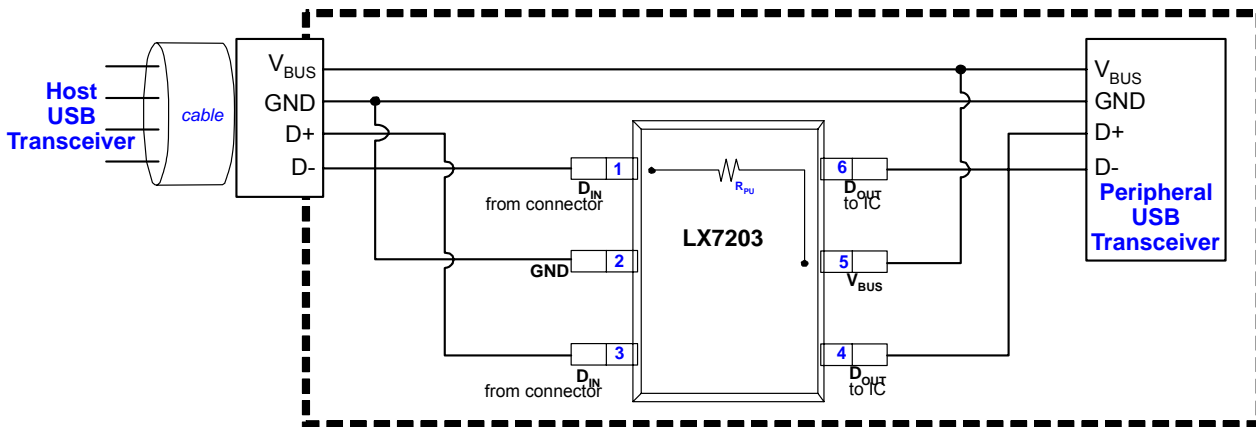

Figure 2 – Connection for Full Speed Operation

**APPLICATION INFORMATION (CONTINUED)**
**LOW SPEED DEVICE (FIGURE 3)**

The USB specification offers a 1.5 Mbps data transfer rate known as Low-Speed which requires a 1.5 kΩ pull-up resistor to be connected to the D- line. Slew rate control is accomplished with C<sub>EDGE</sub> attached to the transceiver before the R<sub>S</sub>.

- Voltage Supply (Vbus) is connected to Pin 5
- Ground is connected to Pin 2
- D+ from the connector is routed to Pin 3 and Pin 4 to the D+ line of the USB Transceiver
- D- from the connector is routed to Pin 1 (1.5 kΩ pull-up resistor) and Pin 6 to the D- line of the USB Transceiver



**Figure 3 – Connection for Low Speed Operation**

**ELECTROMAGNETIC EMISSION AND SUSCEPTABILITY**

FCC Part 15 sets limits for maximum allowable EM emission and susceptibility. There are two types of emissions. Conducted emissions with frequency of emission of 0.45 to 30 MHz and radiated emissions with frequency of emission of 30 MHz to 40 GHz. All digital computing devices including the peripheral devices must comply. Examples of peripheral devices include terminals, printers, external floppy disk drives and other data storage

devices, video monitors, keyboards, control cards, interface boards, external memory expansion cards and other input/output devices that may or may not contain digital circuitry. LX7203 is optimized to minimize the radiated EMI which is the primary concern in devices using USB. Refer to the typical filter response curve for the attenuation characteristics of LX7203 over the frequency range of 30kHz to 6GHz.

CHARACTERISTIC CURVES

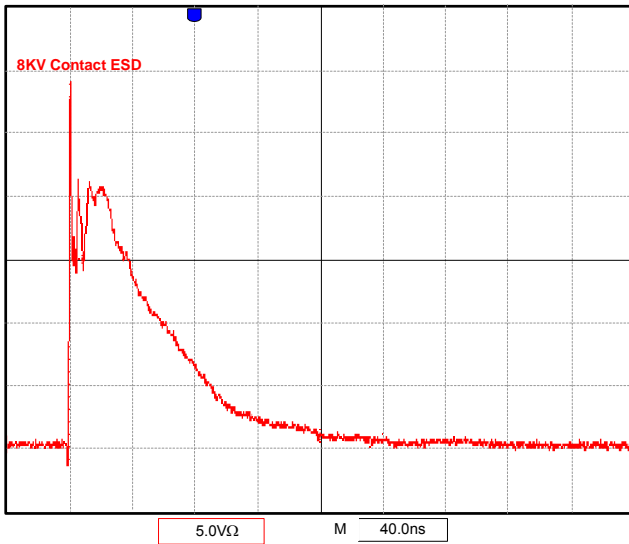

**Figure 4** – 8KV ESD input pulse as per IEC61000-4-2. Vertical scale is equivalent to 5A/div.

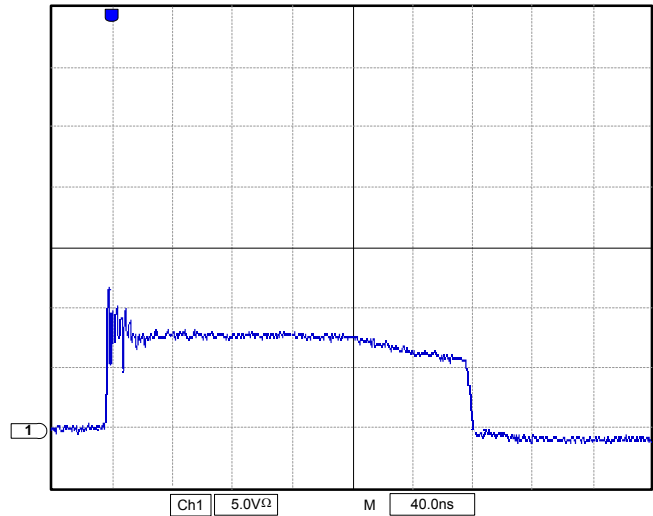

**Figure 5** – Clamping Characteristics when device subjected to an 8 KV ESD pulse.

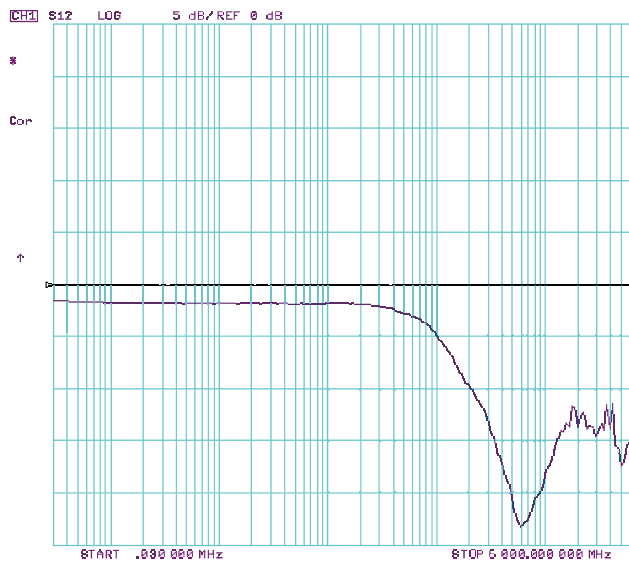

**Figure 6** – Frequency response curve. Low insertion loss in the pass band and -20dB attenuation at 800-900 MHz. Better than -10dB attenuation at the WLAN frequencies of 2.4 and 5.0-6.0 GHz.

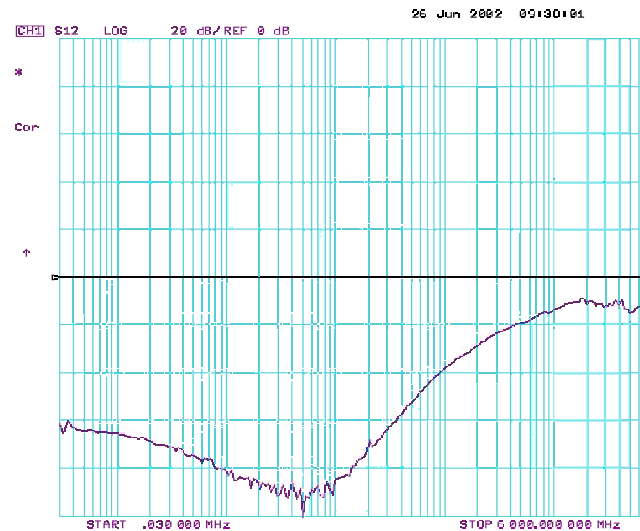

**Figure 7** – Analog Crosstalk between the two datalines D- and D+

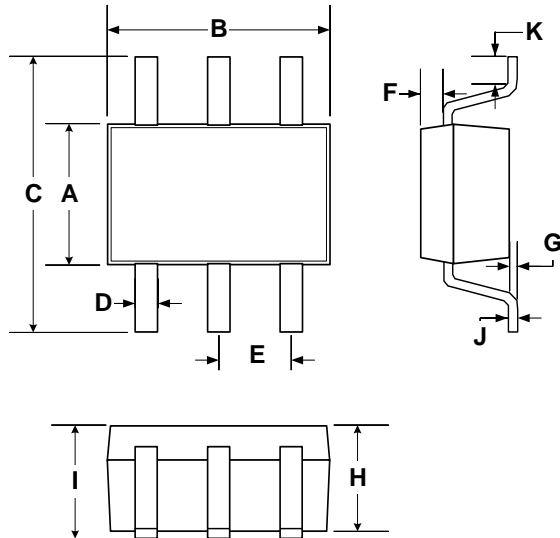
**PACKAGE DIMENSIONS**
**SM 6 Pin Plastic SC70**

Dim	MILLIMETERS		INCHES	
	MIN	MAX	MIN	MAX
A	1.15	1.35	0.045	0.053
B	1.80	2.20	0.071	0.086
C	1.80	2.40	0.071	0.094
D	0.15	0.30	0.006	0.012
E	0.65 BSC		0.026 BSC	
F	0.10	0.40	0.004	0.016
G	0	0.10	0	0.004
H	0.80	1.00	0.032	0.039
I	0.80	1.10	0.032	0.043
J	0.10	0.18	0.004	0.007
K	0.10	0.30	0.004	0.012

**Note:**

- Dimensions do not include mold flash or protrusions; these shall not exceed 0.155mm(.006") on any side. Lead dimension shall not include solder coverage.

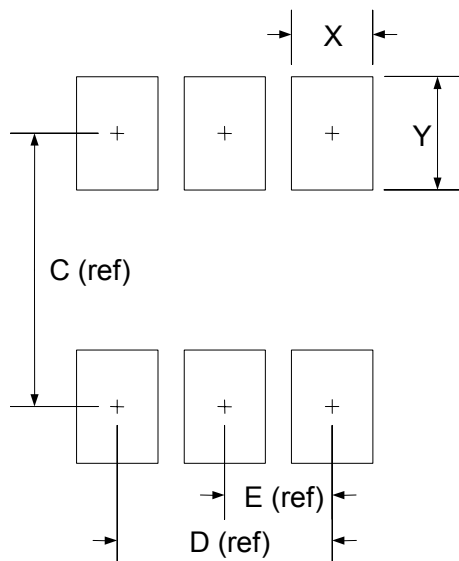
**Recommended Footprint**

Dim	MILLIMETERS		INCHES	
	MIN	MAX	MIN	MAX
C	-	1.60	-	0.063
D	-	1.30	-	0.052
E	-	0.65	-	0.026
X	-	0.35	-	0.014
Y	-	0.90	-	0.035



**Microsemi**  
INTEGRATED PRODUCTS

LX7203-xx

**EMI Filter & ESD Protection for Up Stream USB  
Ports**

PRODUCTION DATA SHEET

NOTES

PRODUCTION DATA – Information contained in this document is proprietary to Microsemi and is current as of publication date. This document may not be modified in any way without the express written consent of Microsemi. Product processing does not necessarily include testing of all parameters. Microsemi reserves the right to change the configuration and performance of the product and to discontinue product at any time.