

PACKAGE DIMENSIONS :

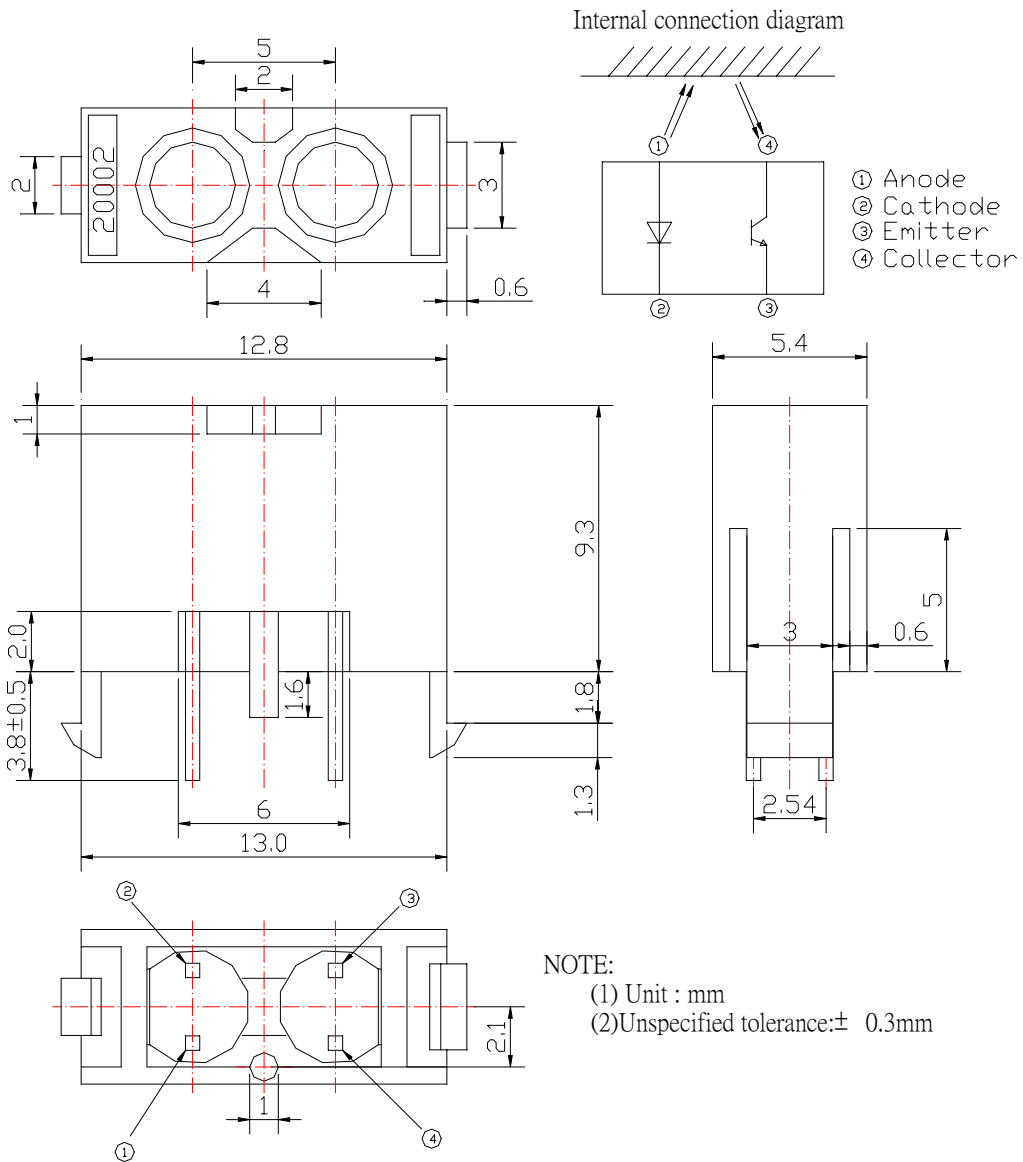

DESIGNER	CHECKER	APPROVED

Office: 7C Building, LIAN HUA SHAN PORT
INDUSTRIAL DISTRICT,
PAN YU, GUANG ZHOU CHINA

Tel: 020-84860913

Fax: 020-84860600

©Notes:

1. Above specification may be changed without notice. EVERLIGHT will reserve Authority on material change for above Specification.
2. These specification sheets include materials protected under copyright of EVERLIGHT corporation. Please don't reproduce or cause anyone to reproduce them without EVERLIGHT's consent.
3. When using this product, please observe the absolute maximum ratings and the instructions for use outlined in these specification sheets. No assumes responsibility for any damage resulting from use of the product which does not comply with the absolute maximum ratings and the instructions included in these specification sheets.

■DESCRIPTION

The **ITR20002** consist of an infrared emitting diode and an NPN silicon phototransistor, encased side-by-side on converging optical axis in a black thermoplastic housing. The phototransistor receives radiation from the IRED only. This is the normal situation. But when an object is in between, phototransistor could not receives the radiation. For additional component information, please refer to **IR4204-9** and **PT4204-6B**.

■FEATURES

ITR:

- Fast response time
- High analytic
- Cut-off visible wavelength $\lambda_p=840\text{nm}$
- High sensitivit
- Pb free

■APPLICATIONS

- Copier
- Scanner
- Non-contact Switching
- For Direct PC Board

ABSOLUTE MAXIMUM RATINGS (Ta=25°C)

Parameter		Symbol	Ratings	Unit
Input	Power Dissipation	Pd	100	mW
	Reverse Voltage	V _R	5	V
	Forward Current	I _F	60	mA
	Peak Forward Current (*1)	I _{FP}	1	A
Output	Collector Power Dissipation	PC	80	mW
	Collector Current	I _C	20	mA
	Collector-Emitter Voltage	V _{CE}	35	V
	Emitter-Collector Voltage	V _{EC}	6	V
Operating Temperature		Topr	-25~+85	°C
Storage Temperature		Tstg	-40~+85	°C
Soldering Temperature (*2)		Tsol	260	°C

(*1) $t_w=100 \mu\text{sec.}$, $T=10 \text{ msec.}$ (*2) $t=5 \text{ Sec}$

ELECTRICAL CHARACTERISTICS (Ta=25°C)

Parameter		Symbol	Min.	Typ.	Max.	Unit	Conditions
Input	Forward Voltage	V _{F1}	-	1.2	1.5	V	I _F =20mA
		V _{F2}	-	1.4	1.85	V	I _F =100mA
		V _{F3}	-	2.6	4.0	V	I _F -Peak=1.0A
	Reverse Current	I _R	-	-	10	μA	V _R =5V
	Peak Wavelength	λ _P	-	940	-	nm	-
	View Angle	2θ _{1/2}	-	30	-	Deg	I _F =20mA
Output	Dark Current	I _{CEO}	-	-	100	nA	V _{CE} =20V
	C-E Saturation Voltage	V _{CE} (sat)	-	-	0.4	V	I _C =0.04mA I _F =40mA
Collector Current (*3)		I _C (on)	0.04	-	0.9	mA	V _{ce} =5V
		I _C (off)	-	-	2	μA	I _f =20mA
Speed	Rise time	t _R	-	20	-	μsec	V _{CE} =2V
	Fall time	t _F	-	25	-	μsec	I _C =100 μA R _L =100Ω

(*3) I_C(on) at the testing condition--with reflector in 7mm away,

I_C(off) at the testing condition--without reflector and external light less than 10 Lux at the module surface.

■ TYPICAL CHARACTERISTICS FOR IR

Fig. 1 Forward Current vs. Ambient Temperature

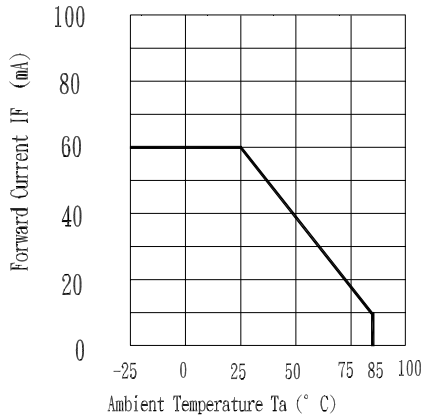

Fig. 2 Spectral Distribution

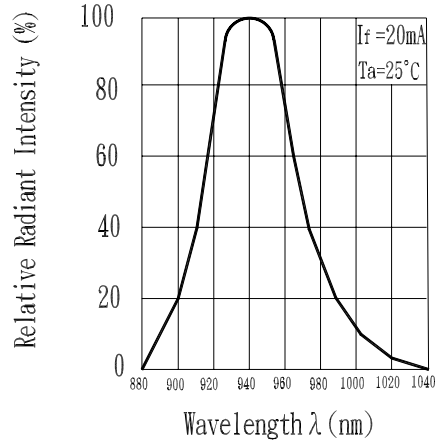

Fig. 3 Peak Emission Wavelength vs. Ambient Temperature

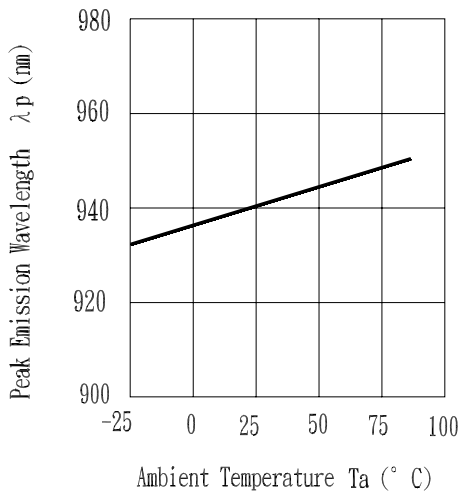

Fig. 4 Forward Current vs. Forward Voltage

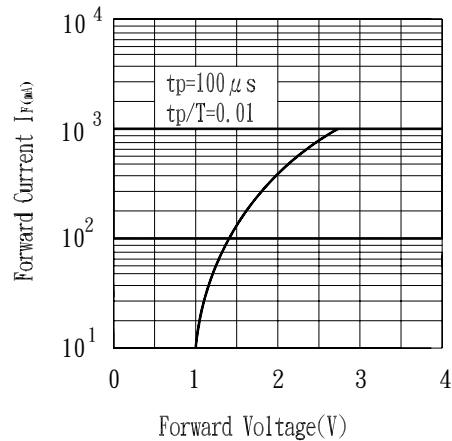

Fig. 5 Relative Intensity vs. Forward Current

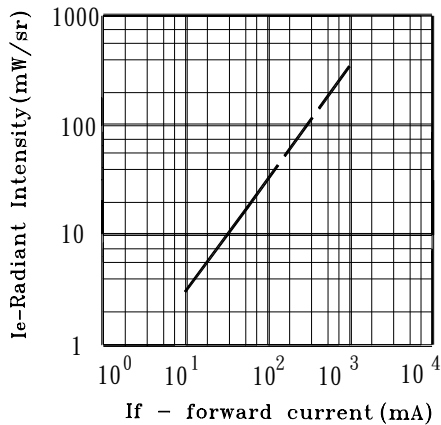
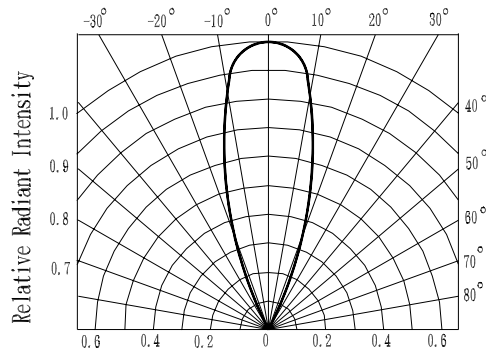
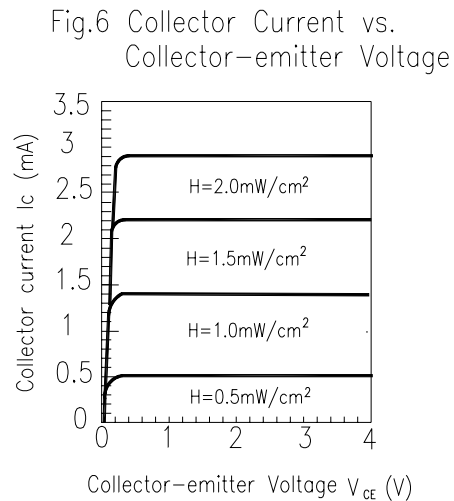
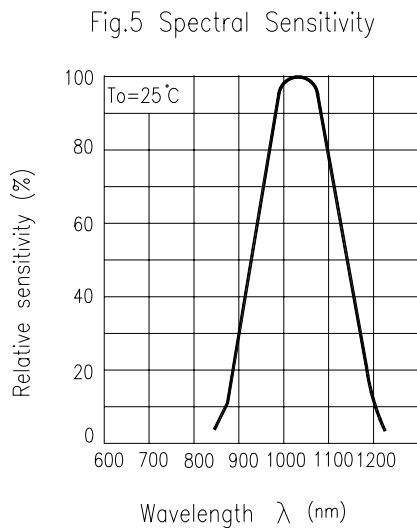
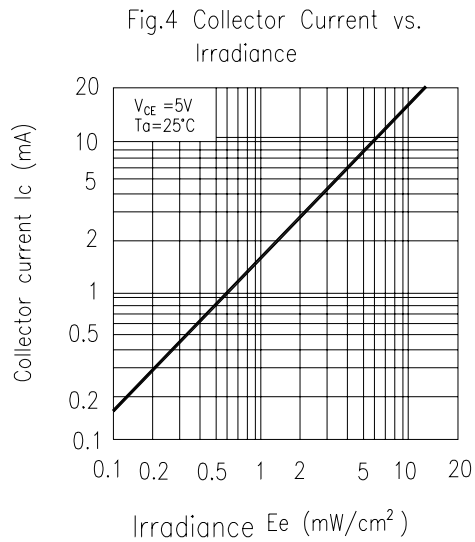
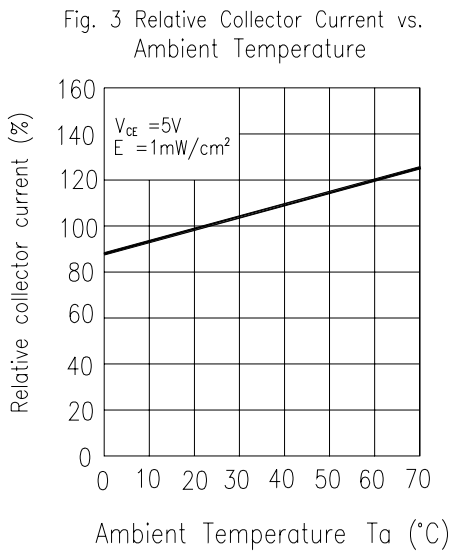
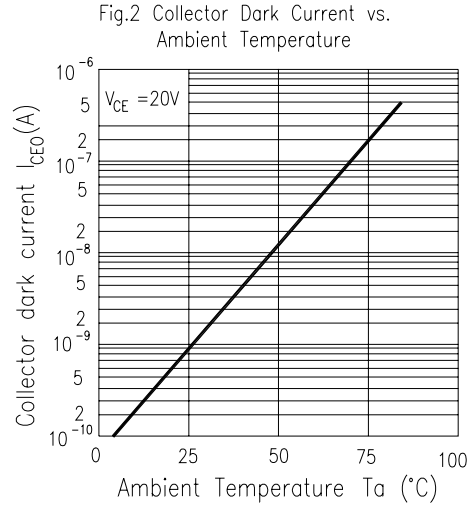
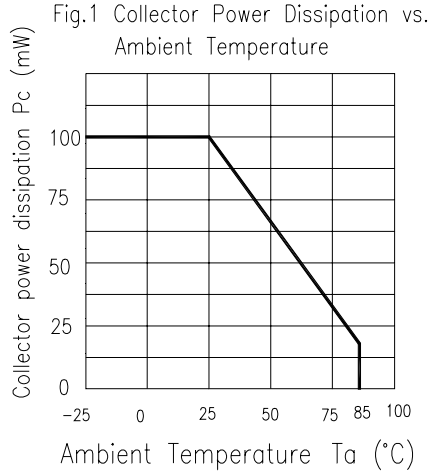

Fig. 6 Relative Radiant Intensity vs. Angular Displacement



■ TYPICAL CHARACTERISTICS FOR PT



CHARACTERISTIC CURVES

Relative output current vs. detecting distance

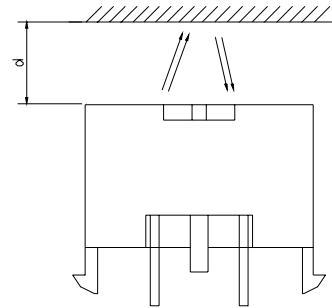
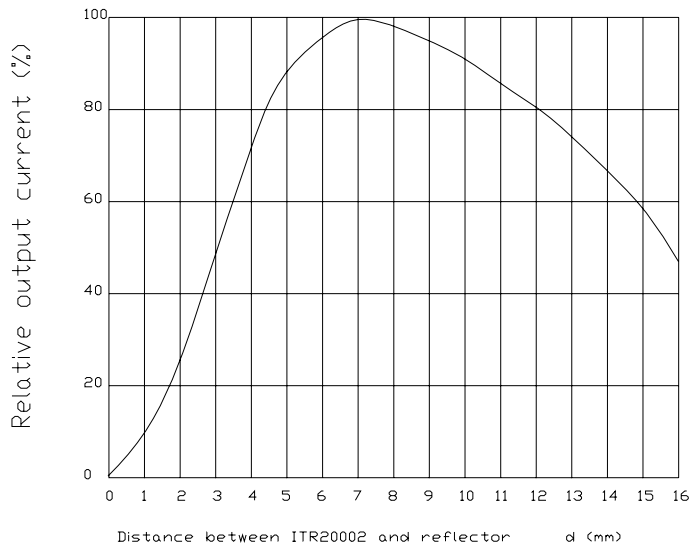

RELIABILITY TEST ITEM AND CONDITION

The reliability of products shall be satisfied with items listed below.

Confidence level : 90%

LTPD : 10%

Items	Purpose & Condition	Failure Judgement Criteria	Samples (n)
			Defective (c)
Temperature Cycle	Evaluates product's ability to withstand exposure to high temperature, low temperature, and temperature variation between two limit temperature. Standard test Condition: $ \begin{array}{cccc} 85^{\circ}\text{C} & \sim & 25^{\circ}\text{C} & \sim & -55^{\circ}\text{C} & \sim & 25^{\circ}\text{C} \\ \downarrow & & \downarrow & & \downarrow & & \downarrow \\ 30\text{min} & & 5\text{min} & & 30\text{min} & & 5\text{min} \\ & & & & & & 50 \text{ cycle} \end{array} $	$I_R \geq U \times 2$ $I_c(\text{on}) \leq L \times 0.8$ $V_F \geq U \times 1.2$ U : Upper specification limit	n = 22 , c = 0
Thermal Shock	Evaluates product's ability to withstand rapid temperature change Standard test Condition: 85°C ~ -55°C 5min(10sec)5min 50cycle	L : Lower specification limit	n = 22 , c = 0
High Temperature Storage	Evaluates product's ability to withstand prolonged storage at high temperature Standard test Condition: Temperature : 100 °C Time : 1000hrs		n = 22 , c = 0
Low Temperature Storage	Evaluates product's ability to withstand prolonged storage at low temperature Standard test Condition: Temperature : -55 °C Time : 1000hrs		n = 22 , c = 0

Items	Purpose & Condition	Failure Judgement Criteria	Samples (n)
			Defective (c)
Operating Life	Evaluates product's endurance to prolonged electrical or temperature stresses. Standard test Condition: $V_{CE}=5V$ $I_F=20mA$ Time : 1000hrs	$I_R \geq U \times 2$ $I_c(on) \leq L \times 0.8$ $V_F \geq U \times 1.2$	n =22 , c=0
High Temperature High Humidity	Evaluates product's ability to withstand prolonged storage at high temperature and high humidity. Standard test Condition: Temperature: 85°C Relative humidity:85% Time : 1000hrs	U : Upper specification limit L : Lower specification limit	n =22 , c=0
Soldering Heat	Evaluates product's ability to withstand soldering heat Standard test conditions Solder temperature : 260±5°C Solder time : 10 seconds		n =22 , c=0

Supplement

1. Parts

(1) Chip

Type	Material	Peak Wavelength
IR	GaAlAs	940nm
PT	Silicon	860nm

(2) Material

Type	Lead frame	Wire	Package	Holder
ITR	SPCC	Gold	Epoxy	NORYL

PACKING SPECIFICATIONS

1. Bag

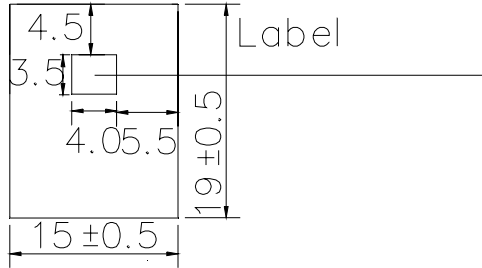

2. Box

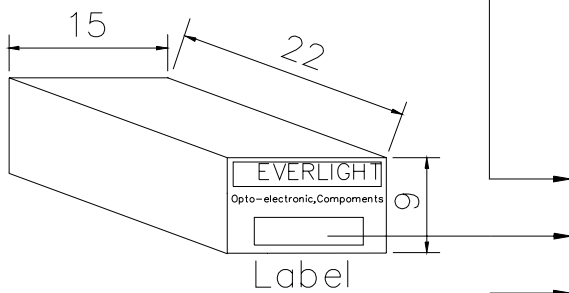

3. Carton

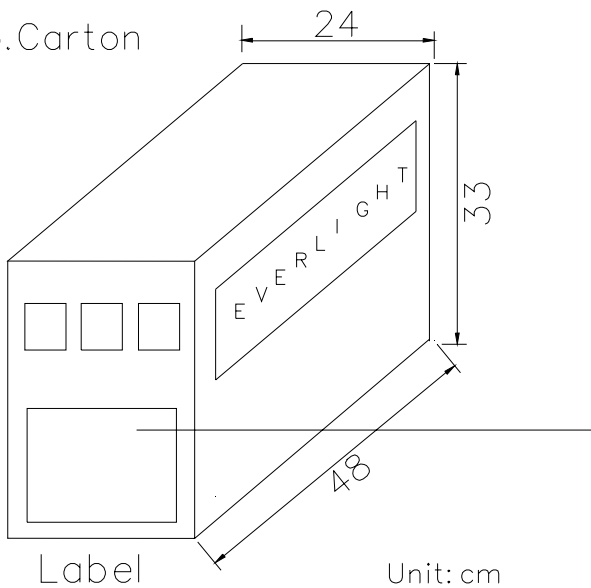

CPN: Customer's product
P/N: Product number
QTY: Packing quantity
CAT: Ranks
HUE: Peak wavelength
REF: Reference
LOT NO: Lot number

Packing Quantity Specification

1. 150Pcs/1Bag

2. 5Bags/1Box

3. 10Boxes/1Carton