

HUL7207

Hologram Unit

For optical information processing

Features

- Smaller package size achieved through micro-mirror integration (4.8 × 8.2 × 4.3 mm)
- Fast response ($f_c = 50$ MHz)
- Focus error signal detection : SSD method
- Tracking error signal detection : 3-beam method
- Low-power semiconductor laser included

Applications

- CD-ROM drives (supports 40 time speed CD-ROM drives)

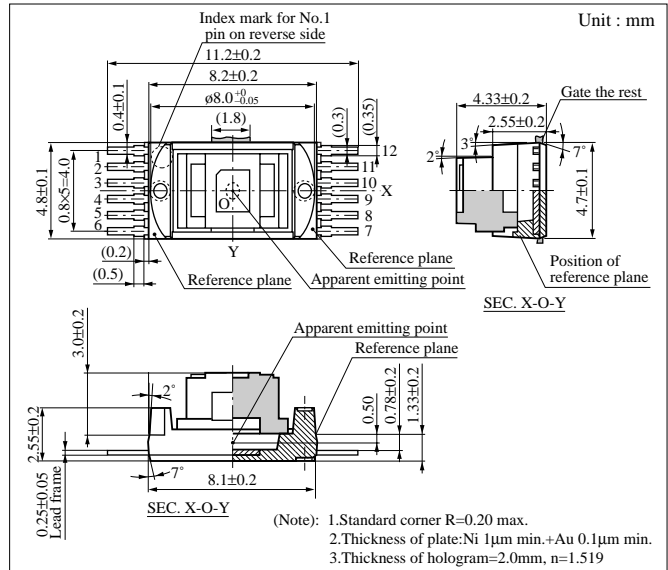

Absolute Maximum Ratings (Ta = 25°C)

Parameter	Symbol	Rated	Unit
Laser beam output*1	P _O	0.3	mW
Laser reverse voltage	V _{R(LD)}	2	V
Monitor PD reverse voltage	V _{R(mon)}	6	V
Supply voltage	V _{CC}	6	V
Operating supply voltage range	V _{CC}	+3.0 to +5.5	V
Reference voltage	V _C	+1.3 to V _{CC} -1.3	V
Operating ambient temperature	T _{opr}	-10 to +60	°C
Storage temperature	T _{stg}	-40 to +85	°C

*1 Light emitting output through objective lens

Unit Characteristic Specifications (Tc = 25±3°C)

Parameter	Symbol	Conditions	min	typ	max	Unit
Laser beam output*1	P _O	V _{RF} = 570mV, V _{CC} = 5V		0.18	0.25	mW
Operating current	I _{OP}	CW V _{RF} = 570mV, V _{CC} = 5V	25	35	45	mA
Operating voltage	V _{OP}	CW V _{RF} = 570mV, V _{CC} = 5V		1.9	2.4	V
Oscillating wavelength	λ _L	V _{RF} = 570mV, V _{CC} = 5V	775	795	815	nm
Focus error signal amplitude	V _{FE}	V _{RF} = 570mV, V _{CC} = 5V	340	480	620	mV
Tracking error signal amplitude	V _{TE}	V _{RF} = 570mV, V _{CC} = 5V	220	340	460	mV
Focus error signal pull-in range	D _{FE}	V _{RF} = 570mV, V _{CC} = 5V	9	12	16	µm
Frequency characteristics	f _C		40	50		MHz

*1 Light emitting output through objective lens

■ Block Diagram of Circuit Functions

